

A
B
C
D
E
F
G
H
I
J
K
L
M
N
O
P

SECTION **VTL**

VENTILATION SYSTEM

CONTENTS

<p>SYSTEM DESCRIPTION 3</p> <p>SWITCHES AND THEIR CONTROL FUNCTION 3</p> <p>WITHOUT ACCS3 WITHOUT ACCS : System Description3</p> <p>WITH ACCS4 WITH ACCS : System Description4</p> <p>AIR DISTRIBUTION 5 System Description5</p> <p>PRECAUTION 6</p> <p>PRECAUTIONS 6 Precaution for Supplemental Restraint System (SRS) "AIR BAG" and "SEAT BELT PRE-TENSIONER"6 Precaution Necessary for Steering Wheel Rotation after Battery Disconnect6 Precaution for Procedure without Cowl Top Cover.....7</p> <p>PREPARATION 8</p> <p>PREPARATION 8 Commercial Service Tool8</p> <p>PERIODIC MAINTENANCE 9</p> <p>IN-CABIN MICROFILTER 9 Exploded View9 Removal and Installation9 Replacement 10</p> <p>REMOVAL AND INSTALLATION11</p> <p>DUCT AND GRILLE11 Exploded View 11</p> <p>CENTER VENTILATOR GRILLE 12</p>	<p>CENTER VENTILATOR GRILLE : Removal and Installation12</p> <p>SIDE VENTILATOR GRILLE12 SIDE VENTILATOR GRILLE : Removal and Installation 12</p> <p>FRONT DEFROSTER GRILLE13 FRONT DEFROSTER GRILLE : Removal and Installation 13</p> <p>SIDE DEFROSTER GRILLE13 SIDE DEFROSTER GRILLE : Removal and Installation 13</p> <p>VENTILATOR DUCT14 VENTILATOR DUCT : Removal and Installation 14</p> <p>ADAPTOR DUCT14 ADAPTOR DUCT : Removal and Installation 14</p> <p>DEFROSTER NOZZLE15 DEFROSTER NOZZLE : Removal and Installation15</p> <p>SIDE DEFROSTER NOZZLE15 SIDE DEFROSTER NOZZLE : Removal and Installation 15</p> <p>SIDE DEFROSTER DUCT16 SIDE DEFROSTER DUCT : Removal and Installation 16</p> <p>REAR VENTILATOR GRILLE16 REAR VENTILATOR GRILLE : Removal and Installation 16</p> <p>REAR VENTILATOR DUCT 116 REAR VENTILATOR DUCT 1 : Removal and Installation 16</p> <p>REAR VENTILATOR DUCT 217 REAR VENTILATOR DUCT 2 : Removal and Installation 17</p>
---	--

VTL

FOOT GRILLE	17	REAR FLOOR DUCT 1 : Removal and Installation	
FOOT GRILLE : Removal and Installation	17		... 19
FOOT DUCT	17	BLOWER UNIT	20
FOOT DUCT : Removal and Installation	18	Exploded View	20
HEATER DUCT	18	BLOWER UNIT	20
HEATER DUCT : Removal and Installation	18	BLOWER UNIT : Removal and Installation	20
REAR FLOOR DUCT 1	18	BLOWER MOTOR	21
		BLOWER MOTOR : Removal and Installation	21

SWITCHES AND THEIR CONTROL FUNCTION

< SYSTEM DESCRIPTION >

SYSTEM DESCRIPTION

SWITCHES AND THEIR CONTROL FUNCTION WITHOUT ACCS

WITHOUT ACCS : System Description

INFOID:000000003887955

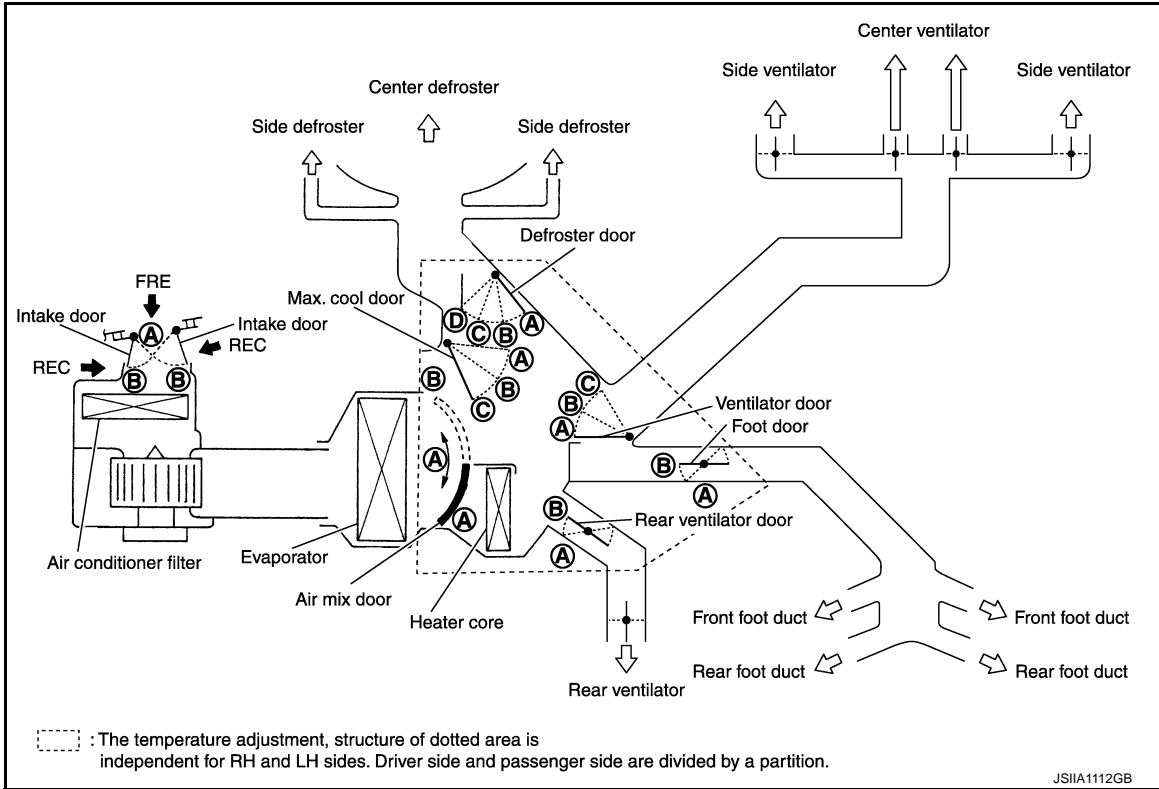

Position or switch	DUAL switch	MODE switch				DEF switch		AUTO switch	Intake switch		Temperature control dial (Driver side)		Temperature control dial (Passenger side)		OFF switch
		VENT	B/L	FOOT	D/F	ON	OFF		FRE	REC					OFF
Door		MODE													OFF
											18°C (60°F)	32°C (90°F)	18°C (60°F)	32°C (90°F)	OFF
Ventilator door	—	(A)	(B)	(C)	(C)	(C)	—	AUTO	—	—	—	—	—	(C)	
Max. cool door	—	(A)	(B)	(C)	(C)	(C)	—	—	—	—	—	—	—	(C)	
Defroster door	—	(D)	(D)	(C)	(B)	(A)	—	—	—	—	—	—	—	(C)	
Foot door	—	(B)	(B)	(B)	(B)	(A)	—	—	—	—	—	—	—	(B)	
Rear ventilator door	—	(B)	(B)	(B)	(B)	(A)	—	—	—	—	—	—	—	(B)	
Intake door	—	—				(B)	(B)	—	(B*)	(A*)	—	—	—	(B)	
Air mix door (Driver side)	—	—				—	—	—	—	—	(A) AUTO	(B)	—	—	
Air mix door (Passenger side)	ON	—				—	—	—	—	—	—	(A) AUTO	(B)	—	
	OFF	—				—	—	—	—	—	(A) AUTO	(B)	—	—	

*: Inlet status is displayed by LED when activating automatic control.

JSIIA1004GB

SWITCHES AND THEIR CONTROL FUNCTION

< SYSTEM DESCRIPTION >

WITH ACCS

WITH ACCS : System Description

INFOID:000000003887956

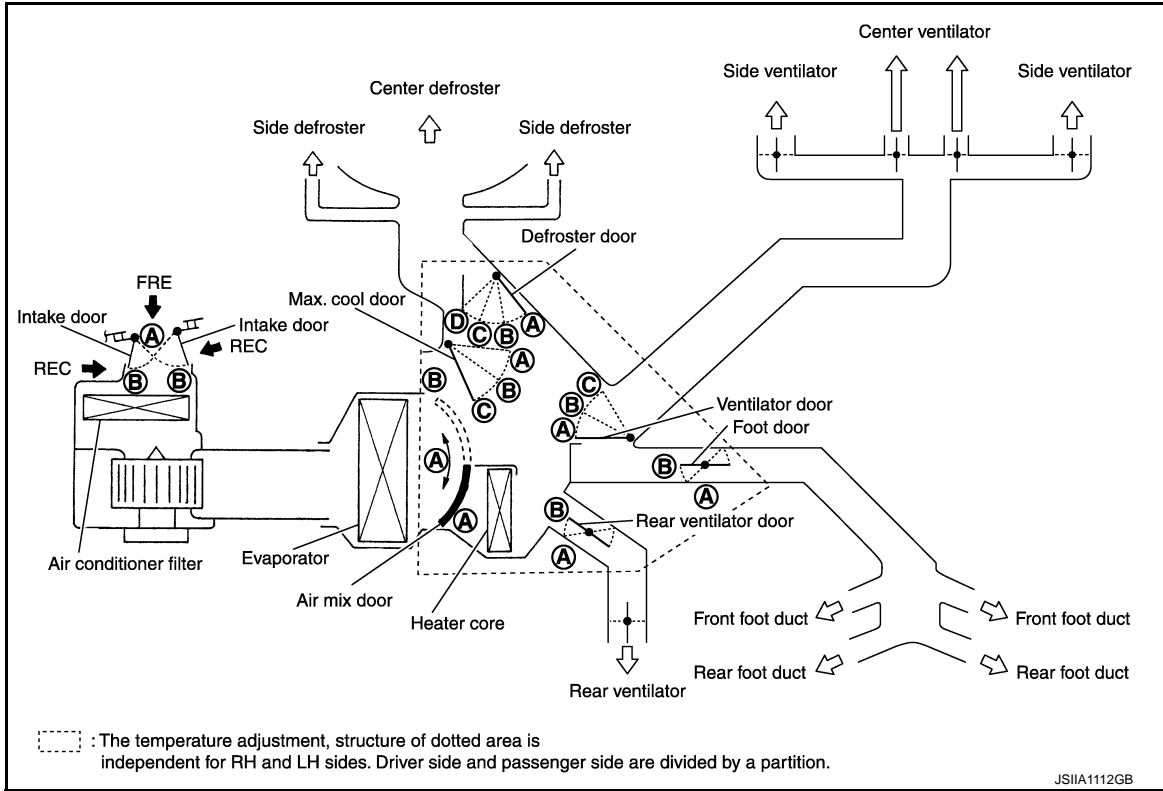

JSIIA1112GB

Position or switch	DUAL switch	MODE switch				DEF switch	AUTO switch	Intake switch			Temperature control dial (Driver side)		Temperature control dial (Passenger side)		OFF switch
		VENT	B/L	FOOT	D/F			AUTO	FRE	REC	18°C (60°F)	32°C (90°F)	18°C (60°F)	32°C (90°F)	
Door		MODE													OFF
	※					※	※	※	—	—	—	—	—	—	OFF
Ventilator door	—	(A)	(B)	(C)	(C)	(C)	AUTO	—	—	—	—	—	—	(C)	
Max. cool door	—	(A)	(B)	(C)	(C)	(C)		—	—	—	—	—	—	—	(C)
Defroster door	—	(D)	(D)	(C)	(B)	(A)		—	—	—	—	—	—	—	(C)
Foot door	—	(B)	(B)	(B)	(B)	(A)		—	—	—	—	—	—	—	(B)
Rear ventilator door	—	(B)	(B)	(B)	(B)	(A)		—	—	—	—	—	—	—	(B)
Intake door	—	—			(B)	(B)		AUTO	(B)	(A)	—	—	—	—	(B)
Air mix door (Driver side)	—	—			—	—	—	—	(A)	AUTO	(B)	—	—	—	
Air mix door (Passenger side)	ON	—			—	—	—	—	—	—	(A)	AUTO	(B)	—	
	OFF	—			—	—	—	—	(A)	AUTO	(B)	—	—	—	

JSIIA1344GB





AIR DISTRIBUTION

< SYSTEM DESCRIPTION >

AIR DISTRIBUTION

System Description

INFOID:000000003887957

Discharge air flow						
Mode position indication	Condition	Air outlet/distribution				
		VENT		FOOT		DEF
		Front	Rear	Front	Rear	
	DUAL switch: OFF Rear ventilator : OPEN	89%	11%	—	—	—
		45%	11%	26%	18%	—
		13%	11%	32%	19%	25%
		10%	10%	28%	17%	35%
		17%	—	—	—	83%

JSIIA1208GB

A
B
C
D
E
F
G
H
VTL
J
K
L
M
N
O
P

VTL

PRECAUTIONS

< PRECAUTION >

PRECAUTION

PRECAUTIONS

Precaution for Supplemental Restraint System (SRS) "AIR BAG" and "SEAT BELT PRE-TENSIONER"

INFOID:000000003888070

The Supplemental Restraint System such as "AIR BAG" and "SEAT BELT PRE-TENSIONER", used along with a front seat belt, helps to reduce the risk or severity of injury to the driver and front passenger for certain types of collision. This system includes seat belt switch inputs and dual stage front air bag modules. The SRS system uses the seat belt switches to determine the front air bag deployment, and may only deploy one front air bag, depending on the severity of a collision and whether the front occupants are belted or unbelted. Information necessary to service the system safely is included in the "SRS AIR BAG" and "SEAT BELT" of this Service Manual.

WARNING:

- To avoid rendering the SRS inoperative, which could increase the risk of personal injury or death in the event of a collision which would result in air bag inflation, all maintenance must be performed by an authorized NISSAN/INFINITI dealer.
- Improper maintenance, including incorrect removal and installation of the SRS, can lead to personal injury caused by unintentional activation of the system. For removal of Spiral Cable and Air Bag Module, see the "SRS AIR BAG".
- Do not use electrical test equipment on any circuit related to the SRS unless instructed to in this Service Manual. SRS wiring harnesses can be identified by yellow and/or orange harnesses or harness connectors.

PRECAUTIONS WHEN USING POWER TOOLS (AIR OR ELECTRIC) AND HAMMERS

WARNING:

- When working near the Air Bag Diagnosis Sensor Unit or other Air Bag System sensors with the ignition ON or engine running, DO NOT use air or electric power tools or strike near the sensor(s) with a hammer. Heavy vibration could activate the sensor(s) and deploy the air bag(s), possibly causing serious injury.
- When using air or electric power tools or hammers, always switch the ignition OFF, disconnect the battery, and wait at least 3 minutes before performing any service.

Precaution Necessary for Steering Wheel Rotation after Battery Disconnect

INFOID:000000003888071

NOTE:

- Before removing and installing any control units, first turn the push-button ignition switch to the LOCK position, then disconnect both battery cables.
- After finishing work, confirm that all control unit connectors are connected properly, then re-connect both battery cables.
- Always use CONSULT-III to perform self-diagnosis as a part of each function inspection after finishing work. If a DTC is detected, perform trouble diagnosis according to self-diagnosis results.

This vehicle is equipped with a push-button ignition switch and a steering lock unit.

If the battery is disconnected or discharged, the steering wheel will lock and cannot be turned.

If turning the steering wheel is required with the battery disconnected or discharged, follow the procedure below before starting the repair operation.

OPERATION PROCEDURE

1. Connect both battery cables.

NOTE:

Supply power using jumper cables if battery is discharged.

2. Turn the push-button ignition switch to ACC position.
(At this time, the steering lock will be released.)
3. Disconnect both battery cables. The steering lock will remain released with both battery cables disconnected and the steering wheel can be turned.
4. Perform the necessary repair operation.

PRECAUTIONS

< PRECAUTION >

5. When the repair work is completed, re-connect both battery cables. With the brake pedal released, turn the push-button ignition switch from ACC position to ON position, then to LOCK position. (The steering wheel will lock when the push-button ignition switch is turned to LOCK position.)
6. Perform self-diagnosis check of all control units using CONSULT-III.

Precaution for Procedure without Cowl Top Cover

INFOID:000000003888072

When performing the procedure after removing cowl top cover, cover the lower end of windshield with urethane, etc.

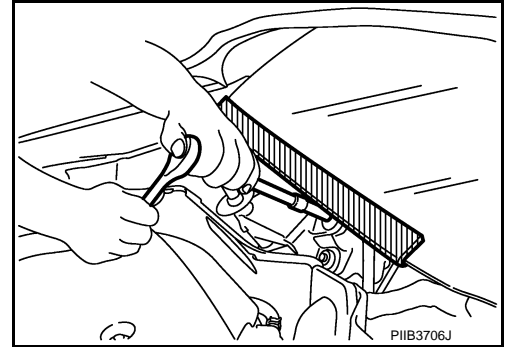

A
B
C
D
E
F
G
H
J
K
L
M
N
O
P

VTL

PREPARATION

< PREPARATION >

PREPARATION

PREPARATION

Commercial Service Tool

INFOID:000000003887969

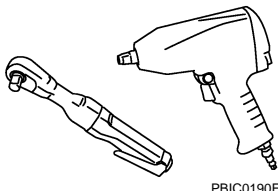
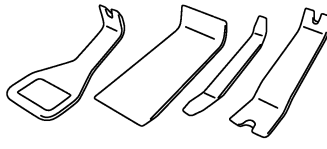
Tool name	Description
<p>Power tool</p>  <p>PBIC0190E</p>	<p>For loosening bolts and nuts</p>
<p>Remover tool</p>  <p>PIIB7923J</p>	<p>Remove clips, pawls, metal clips</p>

IN-CABIN MICROFILTER

< PERIODIC MAINTENANCE >

PERIODIC MAINTENANCE

IN-CABIN MICROFILTER

Exploded View

INFOID:000000004040951

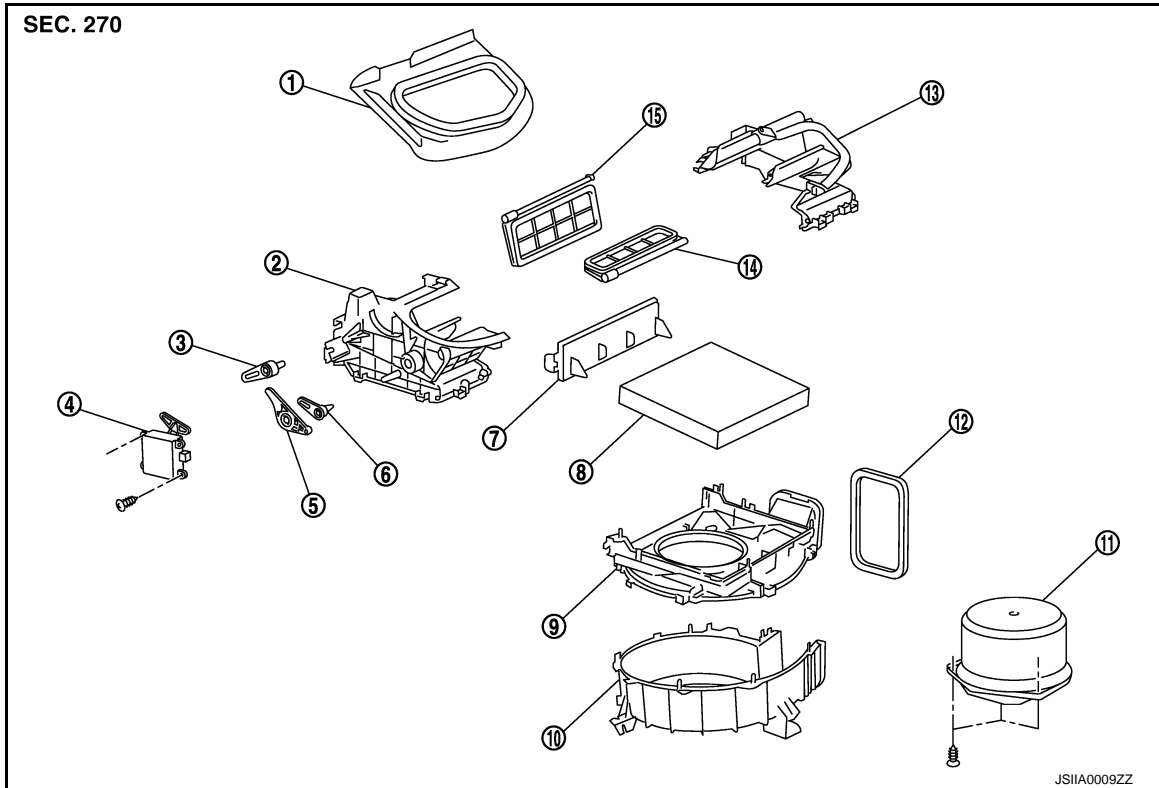

- | | | |
|-----------------------|---------------------------|------------------------|
| 1. Adapter | 2. Intake box (right) | 3. Intake door lever 2 |
| 4. Intake door motor | 5. Intake door link | 6. Intake door lever 1 |
| 7. Filter cover | 8. In-cabin microfilter | 9. Intake upper case |
| 10. Intake lower case | 11. Blower motor assembly | 12. Seal |
| 13. Intake box (left) | 14. Intake door 1 | 15. Intake door 2 |

Removal and Installation

INFOID:000000003887972

REMOVAL

1. Remove instrument lower panel RH. Refer to [IP-11. "Exploded View"](#).
2. Remove filter cover (1), and then remove in-cabin microfilter (2).

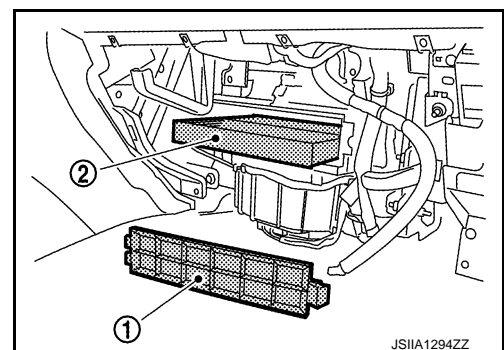

INSTALLATION

Installation is basically the reverse order of removal.

A
B
C
D
E
F
G
H
J
K
L
M
N
O
P

VTL

IN-CABIN MICROFILTER

< PERIODIC MAINTENANCE >

Replacement

INFOID:000000003887973

Replace in-cabin microfilter.

Refer to [MA-7, "Schedule 1"](#) and [MA-9, "Schedule 2"](#).

Affix a caution label inside the glove box when replacing filter.

DUCT AND GRILLE

< REMOVAL AND INSTALLATION >

REMOVAL AND INSTALLATION

DUCT AND GRILLE

Exploded View

INFOID:000000003941310

FRONT

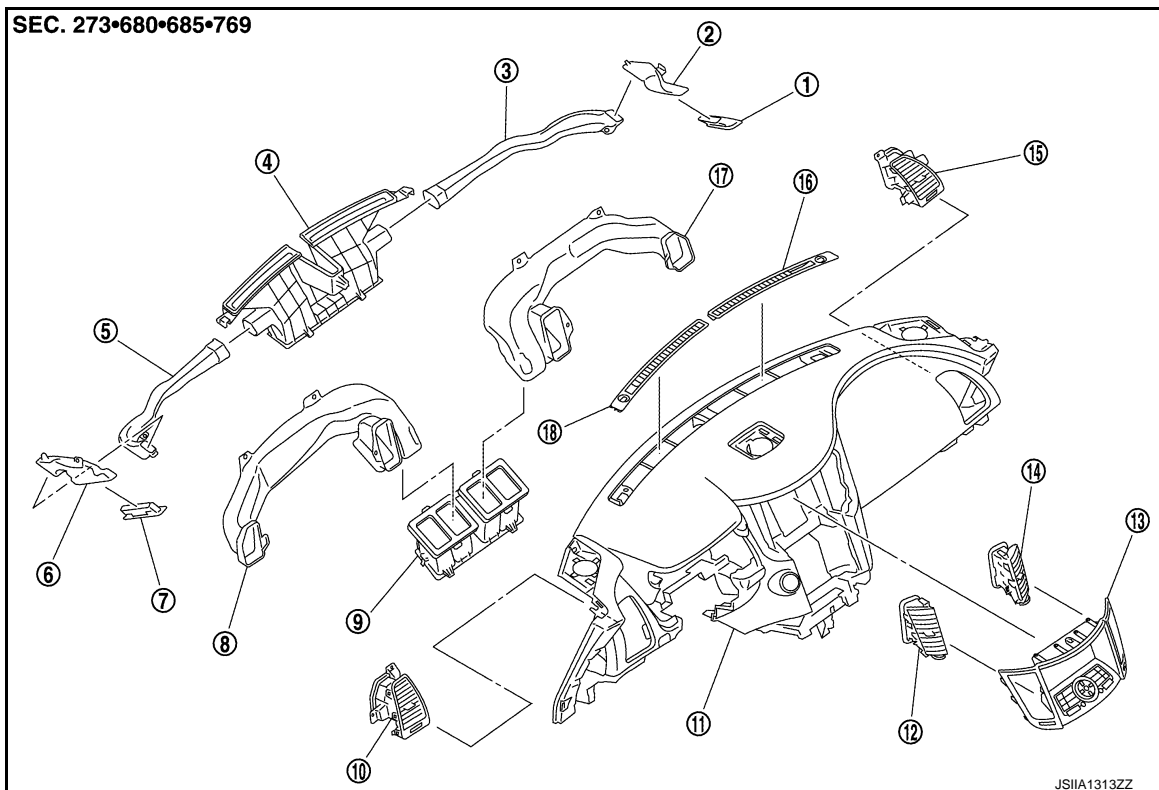

- | | | |
|---|---|--|
| 1. Side defroster grille (front pillar garnish) (right) | 2. Side defroster duct (front pillar garnish) (right) | 3. Side defroster nozzle (right) |
| 4. Defroster nozzle | 5. Side defroster nozzle (left) | 6. Side defroster duct (front pillar garnish) (left) |
| 7. Side defroster grille (front pillar garnish) (left) | 8. Ventilator duct (left) | 9. Adaptor duct |
| 10. Side ventilator grille (left) | 11. Instrument panel assembly | 12. Center ventilator grille (left) |
| 13. Cluster lid D | 14. Center ventilator grille (right) | 15. Side ventilator grille (right) |
| 16. Front defroster grille (right) | 17. Ventilator duct (right) | 18. Front defroster grille (left) |

REAR

DUCT AND GRILLE

< REMOVAL AND INSTALLATION >

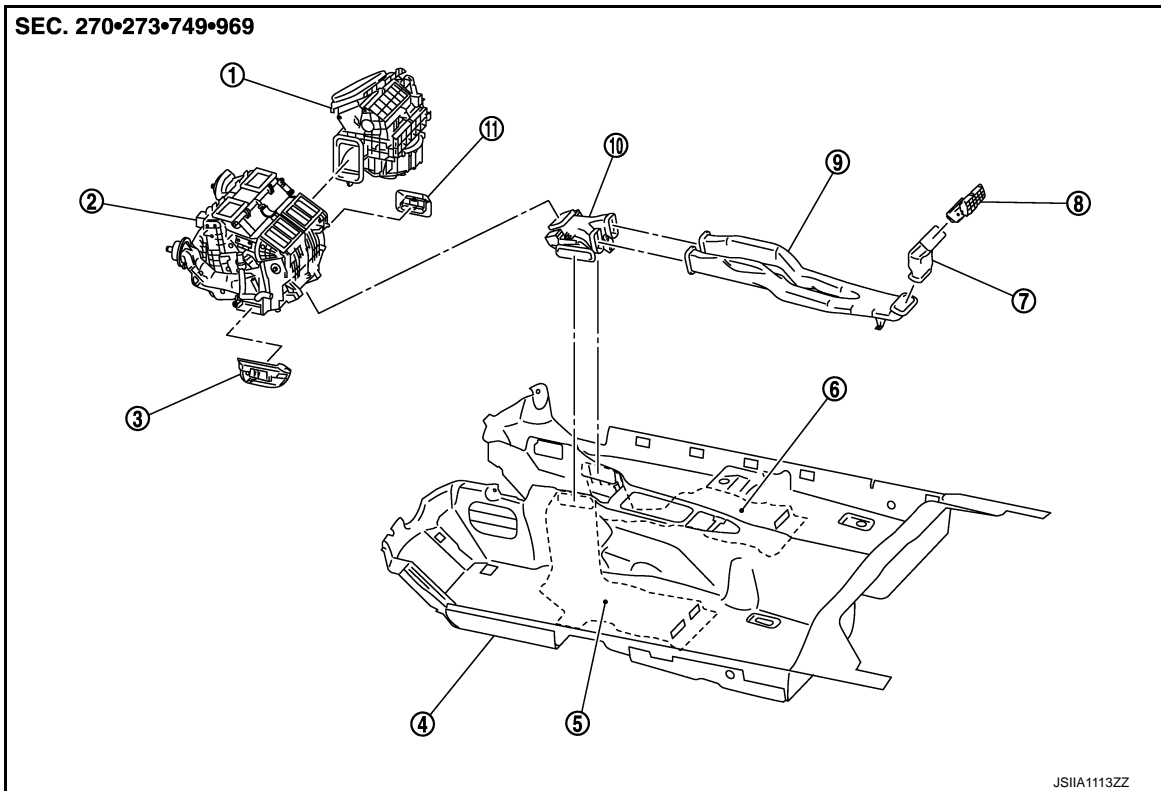

- | | | |
|---------------------------|-----------------------------------|------------------------------|
| 1. Blower unit | 2. Heater & cooling unit assembly | 3. Foot grille (left) |
| 4. Floor carpet | 5. Rear floor duct 2 (left) | 6. Rear floor duct 2 (right) |
| 7. Rear ventilator duct 2 | 8. Rear ventilator grille | 9. Rear ventilator duct 1 |
| 10. Rear floor duct 1 | 11. Foot grille (right) | |

CENTER VENTILATOR GRILLE

CENTER VENTILATOR GRILLE : Removal and Installation

INFOID:000000003888001

REMOVAL

1. Remove cluster lid D. Refer to [IP-11, "Exploded View"](#).
2. Remove mounting screw (A), and then remove center ventilator grilles (1) (left and right).

○: Pawl

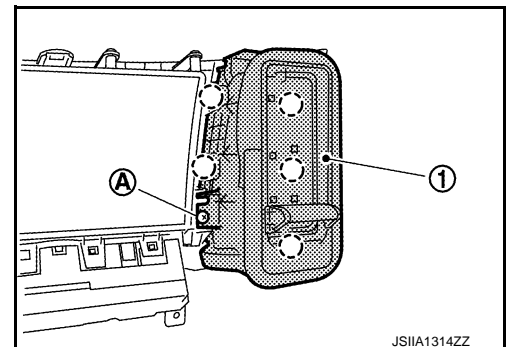

INSTALLATION

Installation is basically the reverse order of removal.

SIDE VENTILATOR GRILLE

SIDE VENTILATOR GRILLE : Removal and Installation

INFOID:000000003888003

REMOVAL

Driver side

DUCT AND GRILLE

< REMOVAL AND INSTALLATION >

1. Remove ventilator duct (left). Refer to [VTL-11. "Exploded View"](#).
2. Remove mounting screws (A), and then remove side ventilator grille (left) (1).

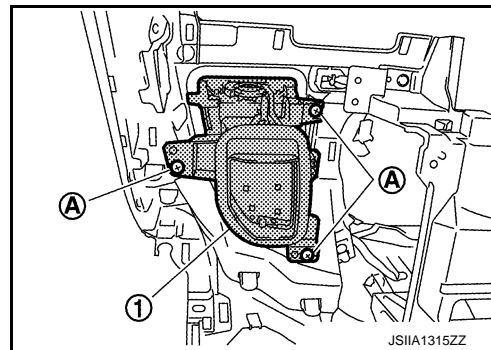

Passenger side

1. Remove ventilator duct (right). Refer to [VTL-11. "Exploded View"](#).
2. Remove mounting screws (A).
3. Remove harness clip (B), and then remove side ventilator grille (right) (1).

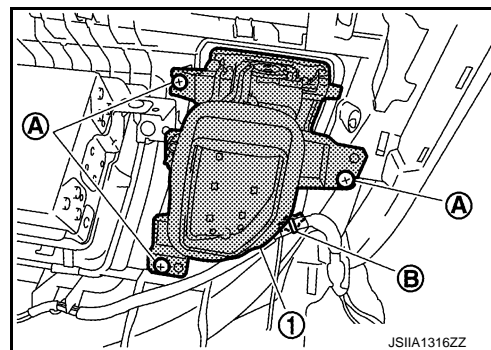

INSTALLATION

Installation is basically the reverse order of removal.

FRONT DEFROSTER GRILLE

FRONT DEFROSTER GRILLE : Removal and Installation

INFOID:000000003888005

REMOVAL

Remove front defroster grilles (1), using remover tools (A).

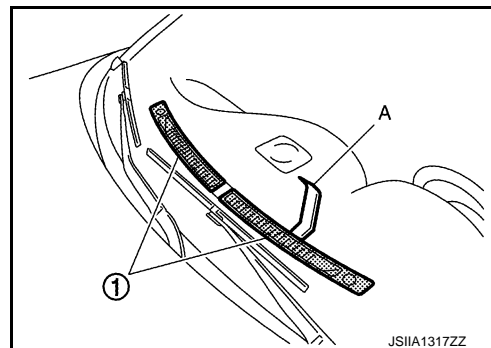

INSTALLATION

Installation is basically the reverse order of removal.

SIDE DEFROSTER GRILLE

SIDE DEFROSTER GRILLE : Removal and Installation

INFOID:000000003932189

REMOVAL

A
B
C
D
E
F
G
H
VTL
J
K
L
M
N
O
P

DUCT AND GRILLE

< REMOVAL AND INSTALLATION >

Remove side defroster grilles (left and right) (1), using remover tools (A).

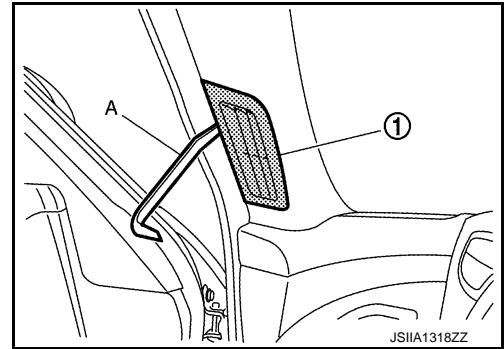

INSTALLATION

Installation is basically the reverse order of removal.

VENTILATOR DUCT

VENTILATOR DUCT : Removal and Installation

INFOID:000000003888007

REMOVAL

1. Remove instrument panel assembly. Refer to [IP-11, "Exploded View"](#).
2. Remove mounting screws (A), and then remove ventilator duct (left) (1) and ventilator duct (right) (2).

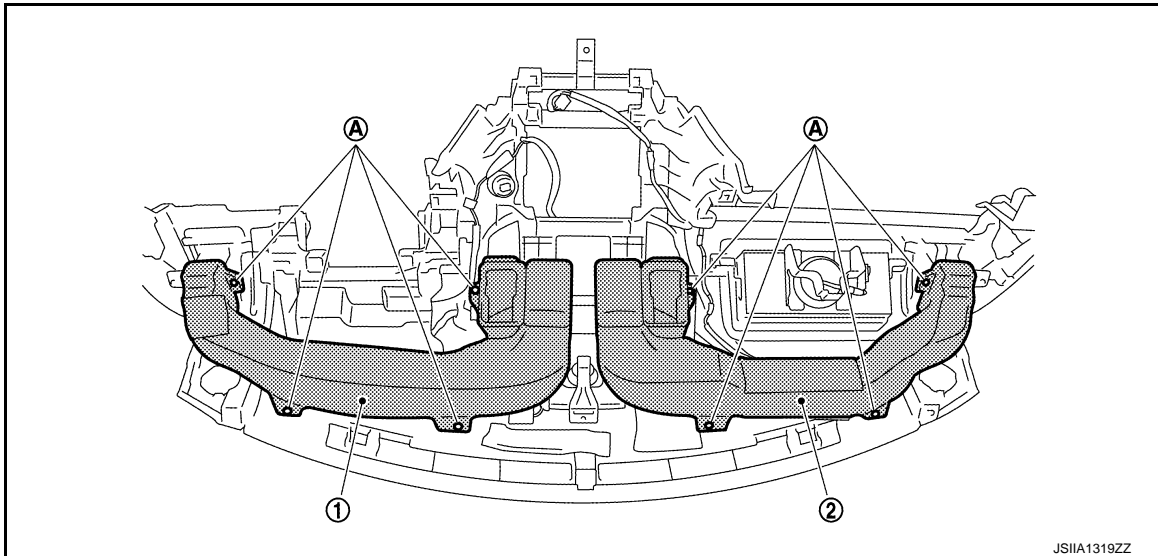

INSTALLATION

Installation is basically the reverse order of removal.

ADAPTOR DUCT

ADAPTOR DUCT : Removal and Installation

INFOID:000000003888009

REMOVAL

1. Remove instrument panel assembly. Refer to [IP-11, "Exploded View"](#).
2. Remove mounting screw (A), and then remove adaptor duct (1).

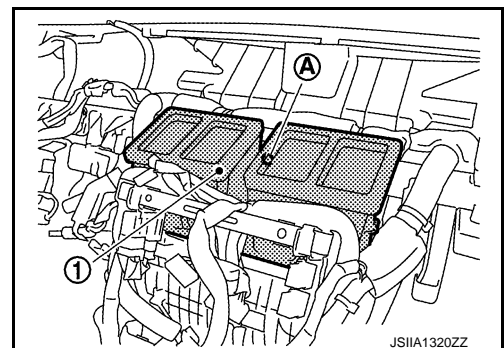

DUCT AND GRILLE

< REMOVAL AND INSTALLATION >

INSTALLATION

Installation is basically the reverse order of removal.

DEFROSTER NOZZLE

DEFROSTER NOZZLE : Removal and Installation

INFOID:000000003888011

REMOVAL

1. Remove side defroster nozzles. Refer to [VTL-11, "Exploded View"](#).
2. Remove defroster nozzle (1).

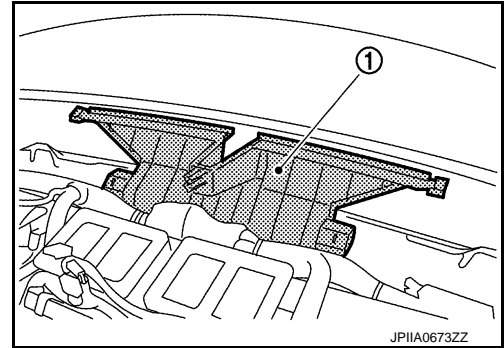

INSTALLATION

Installation is basically the reverse order of removal.

SIDE DEFROSTER NOZZLE

SIDE DEFROSTER NOZZLE : Removal and Installation

INFOID:000000003888013

REMOVAL

Driver side

1. Remove instrument panel assembly. Refer to [IP-11, "Exploded View"](#).
2. Remove mounting clip (A) and harness clip (B), and then remove side defroster nozzle (left) (1).

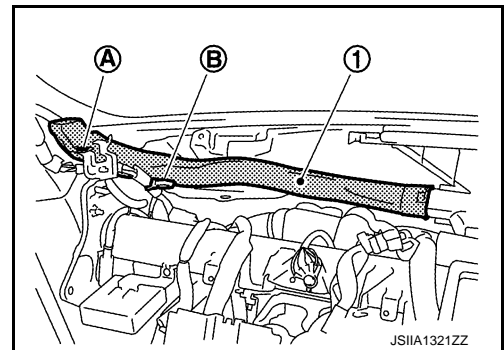

Passenger side

1. Remove instrument panel assembly. Refer to [IP-11, "Exploded View"](#).
2. Remove mounting clip (A), and then remove side defroster nozzle (right) (1).

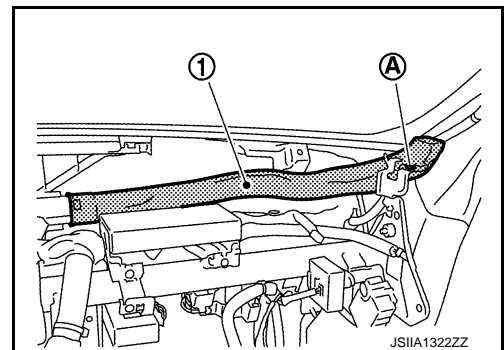

INSTALLATION

Installation is basically the reverse order of removal.

A
B
C
D
E
F
G
H
VTL
J
K
L
M
N
O
P

DUCT AND GRILLE

< REMOVAL AND INSTALLATION >

SIDE DEFROSTER DUCT

SIDE DEFROSTER DUCT : Removal and Installation

INFOID:000000003888015

REMOVAL

1. Remove front pillar garnishes. Refer to [INT-17. "Exploded View"](#).
2. Remove mounting screws (A), and then remove side defroster ducts (left and right) (1).

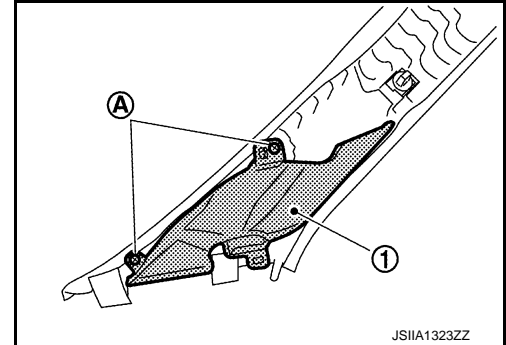

INSTALLATION

Installation is basically the reverse order of removal.

REAR VENTILATOR GRILLE

REAR VENTILATOR GRILLE : Removal and Installation

INFOID:000000003888017

REMOVAL

1. Remove console rear finisher. Refer to [IP-22. "Exploded View"](#).
2. Remove mounting screws (A), and then remove rear ventilator grille (1).

 Pawl

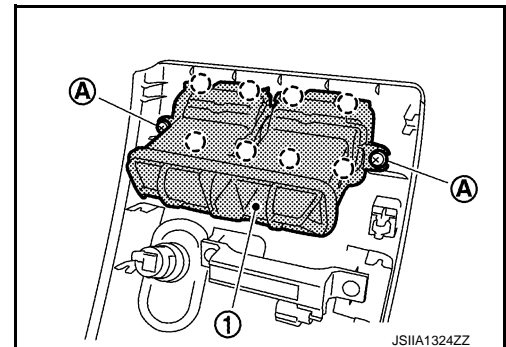

INSTALLATION

Installation is basically the reverse order of removal.

REAR VENTILATOR DUCT 1

REAR VENTILATOR DUCT 1 : Removal and Installation

INFOID:000000003888019

REMOVAL

1. Remove center console assembly. Refer to [IP-22. "Exploded View"](#).
2. Remove mounting screws (A), and then remove rear ventilator duct 1 (1).

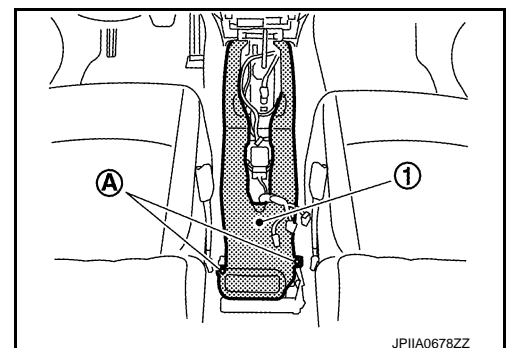

DUCT AND GRILLE

< REMOVAL AND INSTALLATION >

INSTALLATION

Installation is basically the reverse order of removal.

REAR VENTILATOR DUCT 2

REAR VENTILATOR DUCT 2 : Removal and Installation

INFOID:000000003888021

REMOVAL

1. Remove console rear finisher. Refer to [IP-22, "Exploded View"](#).
2. Remove rear ventilator duct 2 (1).

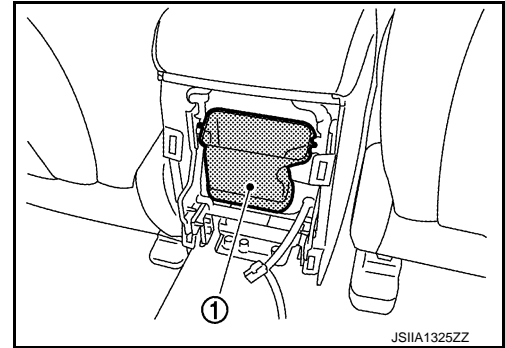

INSTALLATION

Installation is basically the reverse order of removal.

FOOT GRILLE

FOOT GRILLE : Removal and Installation

INFOID:000000003888023

REMOVAL

Driver side

1. Remove foot grille (left) (1).

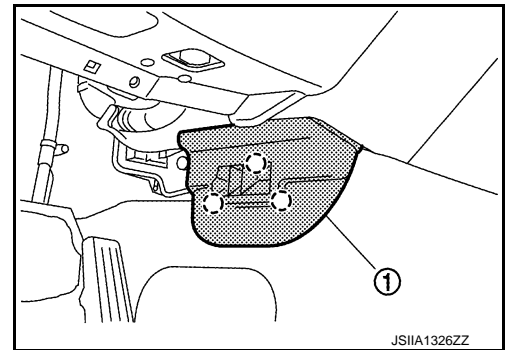

Passenger side

1. Remove foot grille (right) (1).

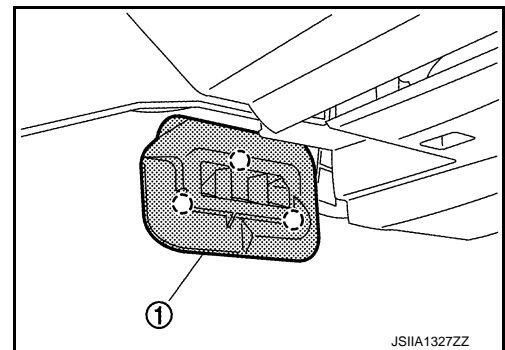

INSTALLATION

Installation is basically the reverse order of removal.

FOOT DUCT

A
B
C
D
E
F
G
H
VTL
J
K
L
M
N
O
P

DUCT AND GRILLE

< REMOVAL AND INSTALLATION >

FOOT DUCT : Removal and Installation

INFOID:000000003888025

REMOVAL

1. Set the temperature at 18.0°C (60°F).
2. Disconnect the battery cable from the negative terminal.
3. Remove heater & cooling unit assembly. Refer to [HA-51. "Exploded View"](#) (VQ35HR) or [HA-108. "Exploded View"](#) (VK50VE).
4. Remove mounting screws (A), and then remove heater pipe cover (1).
5. Remove mounting screws (B), and then remove foot duct (left) (2).

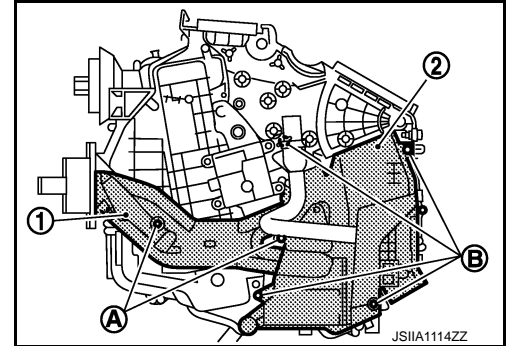

6. Remove air mix door motor (passenger side). Refer to [HAC-187. "Exploded View"](#).
7. Remove mode door motor and links. Refer to [HAC-187. "Exploded View"](#).
8. Remove mounting screws (A), and then remove evaporator cover (1).
9. Remove mounting screws (B), and then remove foot duct (right) (2).

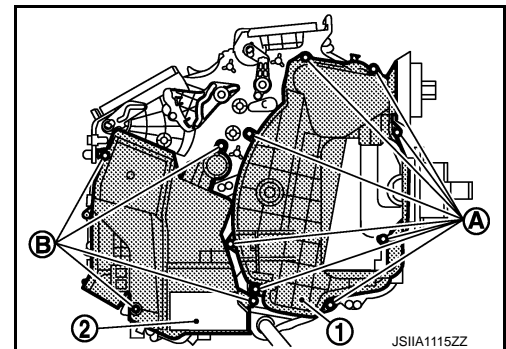

INSTALLATION

Installation is basically the reverse order of removal.

HEATER DUCT

HEATER DUCT : Removal and Installation

INFOID:0000000003932191

REMOVAL

1. Remove instrument lower panel LH. Refer to [IP-11. "Exploded View"](#).
2. Remove mounting screw (A), and then remove heater duct (1).

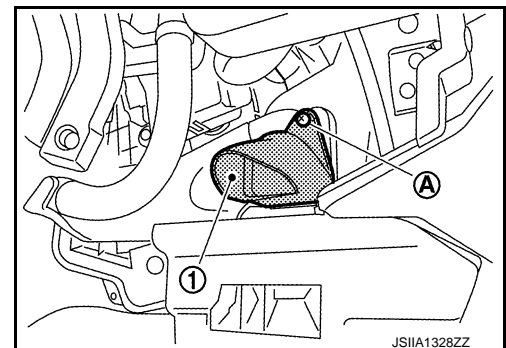

INSTALLATION

Installation is basically the reverse order of removal.

REAR FLOOR DUCT 1

DUCT AND GRILLE

< REMOVAL AND INSTALLATION >

REAR FLOOR DUCT 1 : Removal and Installation

INFOID:000000003888027

REMOVAL

1. Remove instrument panel assembly. Refer to [JP-11, "Exploded View"](#).
2. Remove mounting clips (A), and then remove rear floor duct 1 (1).

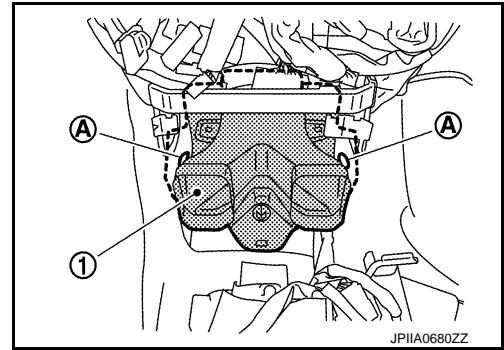

INSTALLATION

Installation is basically the reverse order of removal.

A
B
C
D
E
F
G
H
VTL
J
K
L
M
N
O
P

BLOWER UNIT

< REMOVAL AND INSTALLATION >

BLOWER UNIT

Exploded View

INFOID:000000003941701

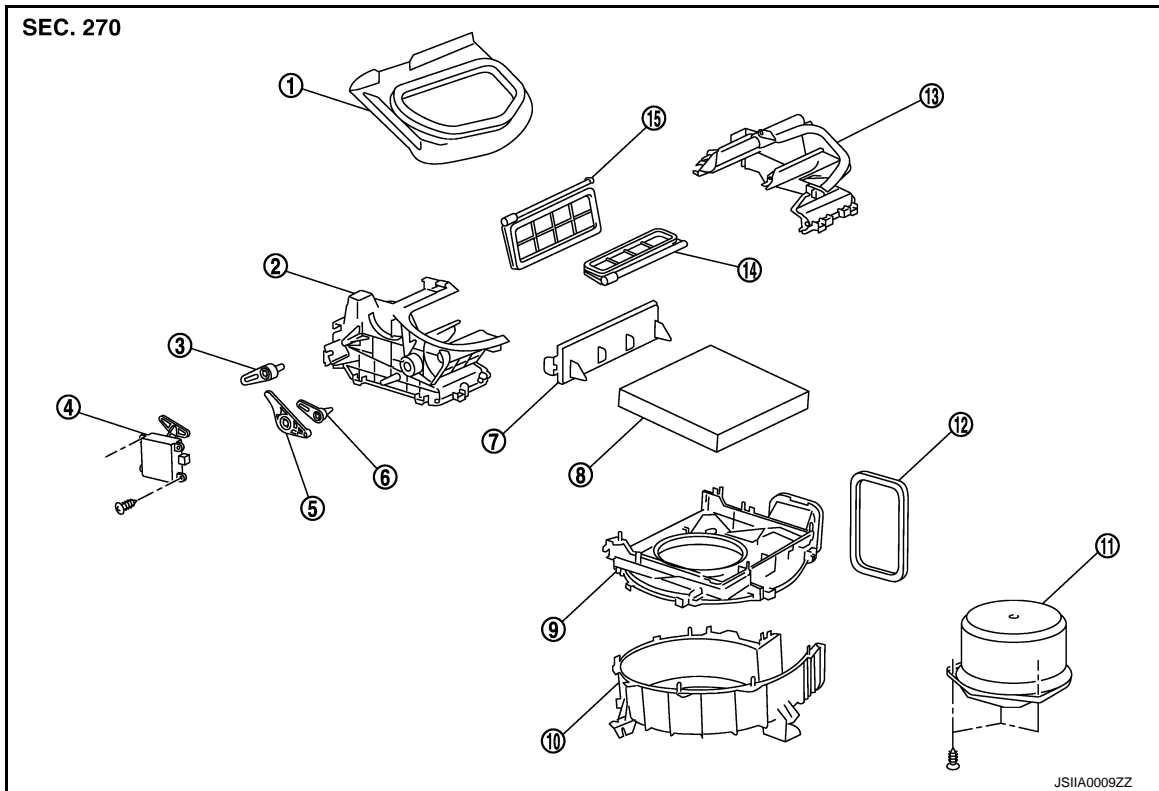

- | | | |
|-----------------------|---------------------------|------------------------|
| 1. Adapter | 2. Intake box (right) | 3. Intake door lever 2 |
| 4. Intake door motor | 5. Intake door link | 6. Intake door lever 1 |
| 7. Filter cover | 8. In-cabin microfilter | 9. Intake upper case |
| 10. Intake lower case | 11. Blower motor assembly | 12. Seal |
| 13. Intake box (left) | 14. Intake door 1 | 15. Intake door 2 |

BLOWER UNIT

BLOWER UNIT : Removal and Installation

INFOID:000000003941702

REMOVAL

1. Remove instrument lower panel RH. Refer to [IP-11, "Exploded View"](#).
2. Disconnect AWD control unit connector (AWD). Refer to [DLN-56, "Exploded View"](#).
3. Disconnect ECM (1) connectors.
4. Remove mounting nuts (A), and then remove ECM with bracket attached.

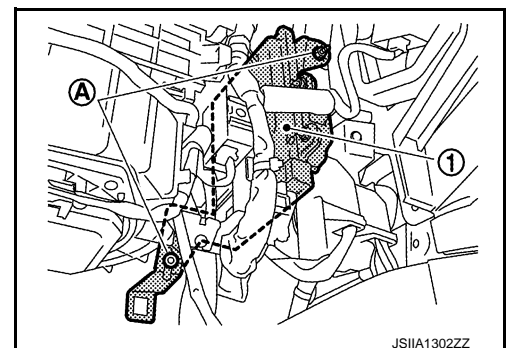

5. Remove power steering control unit. Refer to [STC-25, "Exploded View"](#).
6. Disconnect intake door motor connector and blower motor connector.

BLOWER UNIT

< REMOVAL AND INSTALLATION >

7. Remove mounting bolt (A) and screw (B), from blower unit (1).
8. Remove blower unit.

CAUTION:

Move blower unit rightward, and remove locating pin (1 part) and joint. Then remove blower unit downward.

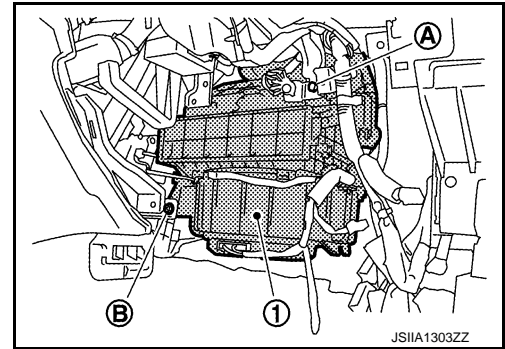

INSTALLATION

Installation is basically the reverse order of removal.

CAUTION:

Make sure locating pin (A) and joint (B) are securely inserted.

←: Vehicle front

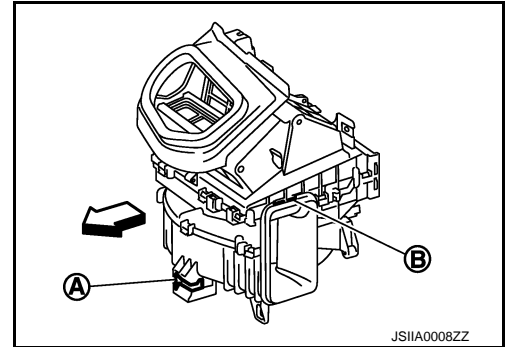

BLOWER MOTOR

BLOWER MOTOR : Removal and Installation

INFOID:000000003941703

VTL

REMOVAL

1. Remove instrument lower cover RH. Refer to [IP-11. "Exploded View"](#).
2. Disconnect blower motor connector.
3. Remove mounting screws (A), and then remove blower motor (1).

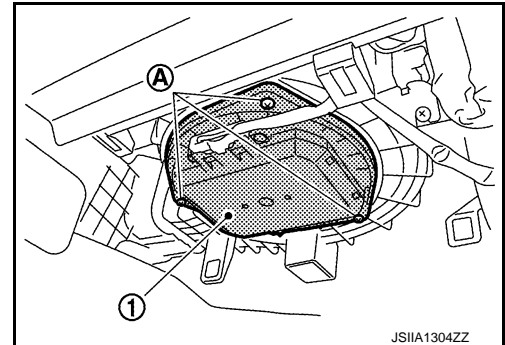

INSTALLATION

Installation is basically the reverse order of removal.