

# STC

SECTION

## STEERING CONTROL SYSTEM

A  
B  
C  
D  
E  
F  
G  
H  
I  
J  
K  
L  
M  
N  
O  
P

### CONTENTS

<p><b>WITHOUT REAR ACTIVE STEER</b></p> <p><b>BASIC INSPECTION</b> ..... 4</p> <p><b>DIAGNOSIS AND REPAIR WORK FLOW</b> ..... 4</p> <p style="padding-left: 20px;">Work Flow .....4</p> <p><b>SYSTEM DESCRIPTION</b> ..... 5</p> <p><b>EPS SYSTEM</b> ..... 5</p> <p style="padding-left: 20px;">System Diagram .....5</p> <p style="padding-left: 20px;">System Description .....5</p> <p style="padding-left: 20px;">Component Parts Location .....7</p> <p style="padding-left: 20px;">Component Description .....7</p> <p><b>DTC/CIRCUIT DIAGNOSIS</b> ..... 8</p> <p><b>POWER SUPPLY AND GROUND CIRCUIT</b> ..... 8</p> <p style="padding-left: 20px;">Description .....8</p> <p style="padding-left: 20px;">Diagnosis Procedure .....8</p> <p><b>POWER STEERING SOLENOID VALVE</b> ..... 9</p> <p style="padding-left: 20px;">Description .....9</p> <p style="padding-left: 20px;">Diagnosis Procedure .....9</p> <p style="padding-left: 20px;">Component Inspection .....10</p> <p><b>ENGINE SPEED SIGNAL CIRCUIT</b> .....11</p> <p style="padding-left: 20px;">Description .....11</p> <p style="padding-left: 20px;">Diagnosis Procedure .....11</p> <p><b>VEHICLE SPEED SIGNAL CIRCUIT</b> .....14</p> <p style="padding-left: 20px;">Description .....14</p> <p style="padding-left: 20px;">Diagnosis Procedure .....14</p> <p><b>ECU DIAGNOSIS INFORMATION</b> .....16</p> <p><b>POWER STEERING CONTROL UNIT</b> .....16</p> <p style="padding-left: 20px;">Reference Value .....16</p> <p style="padding-left: 20px;">Wiring Diagram - ELECTRONICALLY CONTROLLED POWER STEERING SYSTEM - .....18</p> <p style="padding-left: 20px;">Fail-Safe .....20</p> <p><b>SYMPTOM DIAGNOSIS</b> .....22</p>	<p><b>UNBALANCE STEERING WHEEL TURNING FORCE (TORQUE VARIATION)</b> .....22</p> <p style="padding-left: 20px;">Description .....22</p> <p style="padding-left: 20px;">Diagnosis Procedure .....22</p> <p><b>PRECAUTION</b> .....23</p> <p><b>PRECAUTIONS</b> .....23</p> <p style="padding-left: 20px;">Precaution for Supplemental Restraint System (SRS) "AIR BAG" and "SEAT BELT PRE-TENSIONER" .....23</p> <p style="padding-left: 20px;">Precaution Necessary for Steering Wheel Rotation after Battery Disconnect .....23</p> <p><b>REMOVAL AND INSTALLATION</b> .....25</p> <p><b>POWER STEERING CONTROL UNIT</b> .....25</p> <p style="padding-left: 20px;">Exploded View .....25</p> <p style="padding-left: 20px;">Removal and Installation .....25</p> <p style="text-align: center;"><b>WITH REAR ACTIVE STEER</b></p> <p><b>BASIC INSPECTION</b> .....26</p> <p><b>DIAGNOSIS AND REPAIR WORKFLOW</b> .....26</p> <p style="padding-left: 20px;">Work Flow .....26</p> <p><b>SYSTEM DESCRIPTION</b> .....28</p> <p><b>RAS SYSTEM</b> .....28</p> <p style="padding-left: 20px;">System Diagram .....28</p> <p style="padding-left: 20px;">System Description .....28</p> <p style="padding-left: 20px;">Component Parts Location .....30</p> <p style="padding-left: 20px;">Component Description .....31</p> <p><b>EPS SYSTEM</b> .....32</p> <p style="padding-left: 20px;">System Diagram .....32</p> <p style="padding-left: 20px;">System Description .....32</p> <p style="padding-left: 20px;">Component Parts Location .....34</p> <p style="padding-left: 20px;">Component Description .....34</p> <p><b>DIAGNOSIS SYSTEM (RAS CONTROL UNIT)</b> .....35</p>
---	---

STC

Diagnosis Description .....	35	Description .....	59
CONSULT-III Function .....	36	DTC Logic .....	59
<b>DTC/CIRCUIT DIAGNOSIS .....</b>	<b>38</b>	Diagnosis Procedure .....	59
<b>C1900, C1901, C1906, C1907, C1927 RAS</b>		Component Inspection .....	61
<b>CONTROL UNIT .....</b>	<b>38</b>	Special Repair Requirement .....	61
Description .....	38	<b>C1919 VEHICLE SPEED SIGNAL .....</b>	<b>62</b>
DTC Logic .....	38	Description .....	62
Diagnosis Procedure .....	38	DTC Logic .....	62
Special Repair Requirement .....	39	Diagnosis Procedure .....	62
<b>C1902, C1903, C1904, C1910, C1913 RAS</b>		Special Repair Requirement .....	63
<b>MOTOR OUTPUT .....</b>	<b>40</b>	<b>C1920 STEERING ANGLE SENSOR .....</b>	<b>64</b>
Description .....	40	Description .....	64
DTC Logic .....	40	DTC Logic .....	64
Diagnosis Procedure .....	40	Diagnosis Procedure .....	64
Component Inspection .....	42	Special Repair Requirement .....	65
Special Repair Requirement .....	42	<b>C1921 ENGINE SPEED SIGNAL .....</b>	<b>66</b>
<b>C1905, C1908, C1922, C1925, C1928 RAS</b>		Description .....	66
<b>CONTROL UNIT .....</b>	<b>44</b>	DTC Logic .....	66
Description .....	44	Diagnosis Procedure .....	66
DTC Logic .....	44	Special Repair Requirement .....	67
Diagnosis Procedure .....	44	<b>C1923 STEERING ANGLE SENSOR .....</b>	<b>68</b>
Special Repair Requirement .....	45	Description .....	68
<b>C1909 RAS CONTROL UNIT .....</b>	<b>46</b>	DTC Logic .....	68
Description .....	46	Diagnosis Procedure .....	68
DTC Logic .....	46	Special Repair Requirement .....	69
Diagnosis Procedure .....	46	<b>C1924 STEERING ANGLE SENSOR .....</b>	<b>70</b>
Special Repair Requirement .....	47	Description .....	70
<b>C1911, C1912 RAS MOTOR POWER SUP-</b>		DTC Logic .....	70
<b>PLY .....</b>	<b>48</b>	Diagnosis Procedure .....	70
Description .....	48	Special Repair Requirement .....	71
DTC Logic .....	48	<b>C1926 STEERING ANGLE SENSOR .....</b>	<b>72</b>
Diagnosis Procedure .....	48	Description .....	72
Component Inspection (RAS Motor Relay) .....	51	DTC Logic .....	72
Component Inspection (Noise Suppressor) .....	51	Diagnosis Procedure .....	72
Special Repair Requirement .....	52	Special Repair Requirement .....	73
<b>C1914 REAR WHEEL STEERING ANGLE</b>		<b>C1929 ABS ACTUATOR AND ELECTRIC</b>	
<b>SENSOR .....</b>	<b>53</b>	<b>UNIT (CONTROL UNIT) .....</b>	<b>74</b>
Description .....	53	Description .....	74
DTC Logic .....	53	DTC Logic .....	74
Diagnosis Procedure .....	53	Diagnosis Procedure .....	74
Component Inspection .....	54	Special Repair Requirement .....	75
Special Repair Requirement .....	55	<b>U1000 CAN COMM CIRCUIT .....</b>	<b>76</b>
<b>C1915, C1916 REAR WHEEL STEERING AN-</b>		Description .....	76
<b>GLE SENSOR .....</b>	<b>56</b>	DTC Logic .....	76
Description .....	56	Diagnosis Procedure .....	76
DTC Logic .....	56	Special Repair Requirement .....	76
Diagnosis Procedure .....	56	<b>U1010 CONTROL UNIT (CAN) .....</b>	<b>77</b>
Component Inspection .....	58	Description .....	77
Special Repair Requirement .....	58	DTC Logic .....	77
<b>C1917, C1918 REAR WHEEL STEERING AN-</b>		Diagnosis Procedure .....	77
<b>GLE SENSOR .....</b>	<b>59</b>	Special Repair Requirement .....	77

<b>POWER SUPPLY AND GROUND CIRCUIT</b> .....78	<b>SYMPTOM DIAGNOSIS</b> ..... 101	
Description .....78		A
Diagnosis Procedure .....78	<b>RAS WARNING LAMP DOSE NOT TURN ON.</b> 101	
Component Inspection (RAS Motor Relay) .....80	Description .....101	
Component Inspection (Noise Suppressor) .....81	Diagnosis Procedure .....101	B
<b>POWER STEERING SOLENOID VALVE</b> .....82	<b>RAS WARNING LAMP DOSE NOT TURN OFF</b> ..... 102	
Description .....82	Description .....102	C
Diagnosis Procedure .....82	Diagnosis Procedure .....102	
Component Inspection .....83	<b>UNBALANCE STEERING WHEEL TURNING FORCE (TORQUE VARIATION)</b> ..... 103	
<b>RAS WARNING LAMP</b> .....84	Description .....103	D
Description .....84	Diagnosis Procedure .....103	
Component Function Check .....84	<b>PRECAUTION</b> ..... 104	E
Diagnosis Procedure .....84		
Special Repair Requirement .....85	<b>PRECAUTIONS</b> ..... 104	
<b>STOP LAMP SWITCH</b> .....86	Precaution for Supplemental Restraint System (SRS) "AIR BAG" and "SEAT BELT PRE-TENSIONER" .....104	F
Description .....86	Precaution Necessary for Steering Wheel Rotation after Battery Disconnect .....104	
Component Function Check .....86		
Diagnosis Procedure .....86	<b>REMOVAL AND INSTALLATION</b> ..... 106	H
Component Inspection .....86		
Special Repair Requirement .....87	<b>RAS CONTROL UNIT</b> ..... 106	
<b>ECU DIAGNOSIS INFORMATION</b> .....88	Exploded View .....106	I
	Removal and Installation .....106	
<b>RAS CONTROL UNIT</b> .....88	<b>REAR ACTIVE STEER</b> ..... 107	
Reference Value .....88	Exploded View .....107	J
Wiring Diagram - RAS SYSTEM - .....91	Removal and Installation .....107	
Fail-Safe .....96		
DTC Inspection Priority Chart .....98		
DTC Index .....98		
		K
		L
		M
		N
		O
		P

**STC**

## BASIC INSPECTION

### DIAGNOSIS AND REPAIR WORK FLOW

#### Work Flow

INFOID:000000003826282

#### DETAILED FLOW

#### 1. COLLECT THE INFORMATION FROM THE CUSTOMER

It is also important to clarify customer complaints before inspection. First of all, reproduce symptoms and understand them fully. Ask customer about his/her complaints carefully. In some cases, it is necessary to check symptoms by driving vehicle with customer.

**CAUTION:**

**Customers are not professional. It is dangerous to make an easy guess like “maybe the customer means that...,” or “maybe the customer mentions this symptom”.**

&gt;&gt; GO TO 2.

#### 2. CHECK THE STATUS

1. Power steering fluid leakage and check the power steering fluid level. Refer to [ST-11, "Inspection"](#).
2. Check the drive belt tension. Refer to [EM-15, "Checking"](#) (VQ35HR), [EM-163, "Checking"](#) (VK50VE).
3. Check the power steering gear for damages, cracks and fluid leakage. Refer to [ST-33, "Inspection"](#).
4. Check the relief oil pressure. Refer to [ST-39, "VQ35HR : Inspection"](#) (VQ35HR), [ST-45, "VK50VE : Inspection"](#) (VK50VE).

&gt;&gt; GO TO 3.

#### 3. DIAGNOSIS CHART BY SYMPTOM

Perform the diagnosis by symptom. Refer to [STC-22, "Diagnosis Procedure"](#).

&gt;&gt; GO TO 4.

#### 4. FINAL CHECK

Check the input/output standard values for the power steering control unit.

Are the power steering control unit input/output values within standard ranges respectively?

- YES >> INSPECTION END  
NO >> GO TO 2.

# EPS SYSTEM

< SYSTEM DESCRIPTION >

[WITHOUT REAR ACTIVE STEER]

## SYSTEM DESCRIPTION

### EPS SYSTEM

#### System Diagram

INFOID:000000003826283

#### CONTROL DIAGRAM

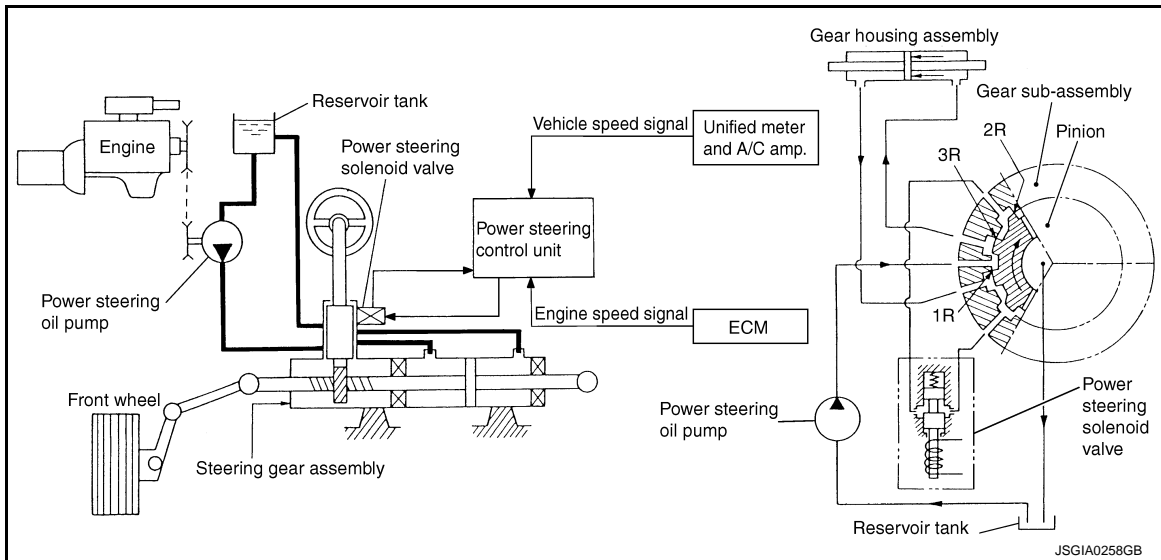

#### CROSS-SECTIONAL VIEW

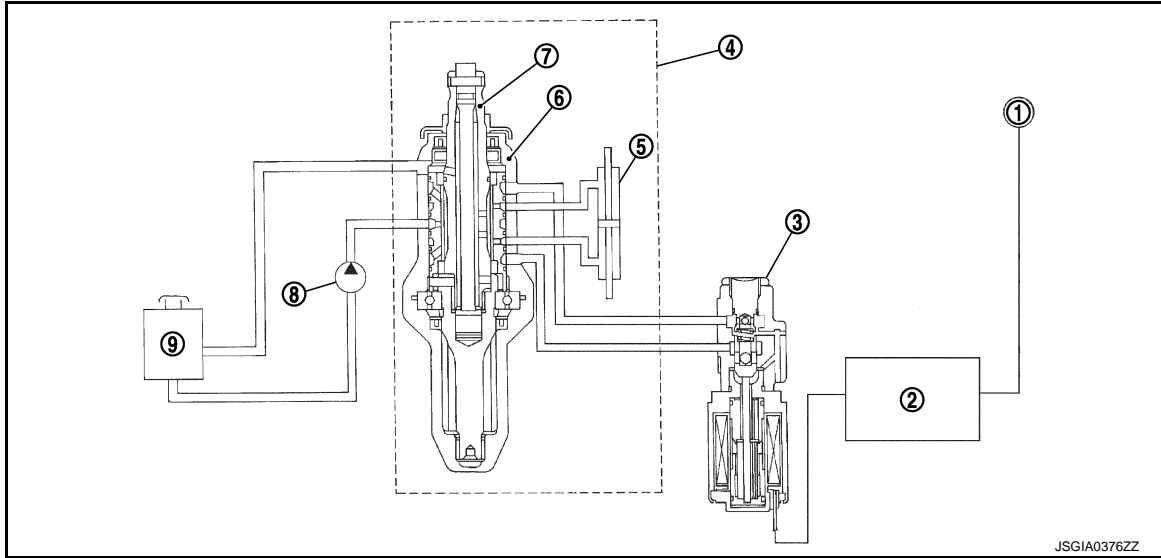

- |                               |                                |                                  |
|-------------------------------|--------------------------------|----------------------------------|
| 1. Unified meter and A/C amp. | 2. Power steering control unit | 3. Power steering solenoid valve |
| 4. Steering gear assembly     | 5. Gear housing assembly       | 6. Gear sub-assembly             |
| 7. Pinion                     | 8. Power steering oil pump     | 9. Reservoir tank                |

#### System Description

INFOID:000000003826284

- The EPS system controls the power steering solenoid valve through the power steering control unit.

# EPS SYSTEM

## < SYSTEM DESCRIPTION >

[WITHOUT REAR ACTIVE STEER]

- The valve driving voltage to control the power steering solenoid valve varies according to the vehicle speed.

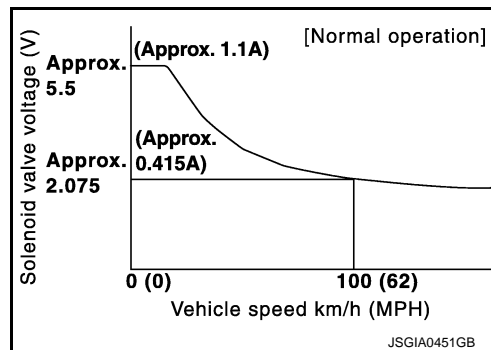

## OPERATION PRINCIPLE

During Parking (When Turning The Steering Wheel To The Right.)

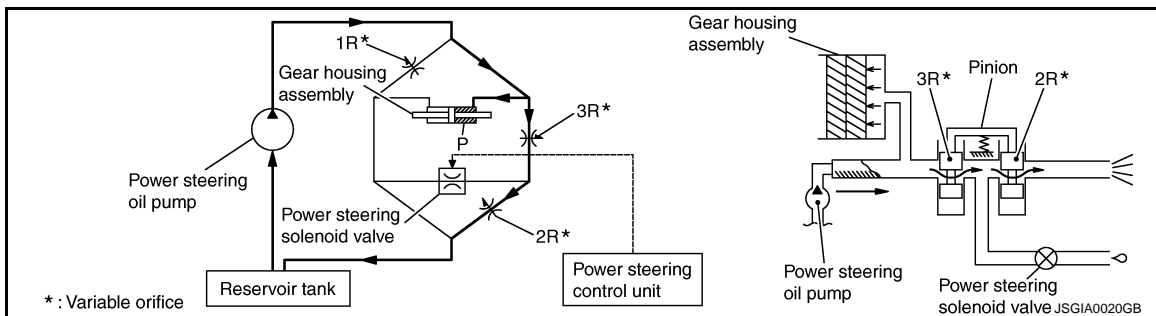

- Power steering solenoid valve is closed while a vehicle is stopped.
- Pinion "1R", "2R" and "3R" are closed depending on steering torque of steering wheel.
- Oil pressure "P" in the gear housing assembly is the sum of oil pressures occurred in "2R" and "3R". This results in a light steering force because of high pressure.

During High-speed Operation

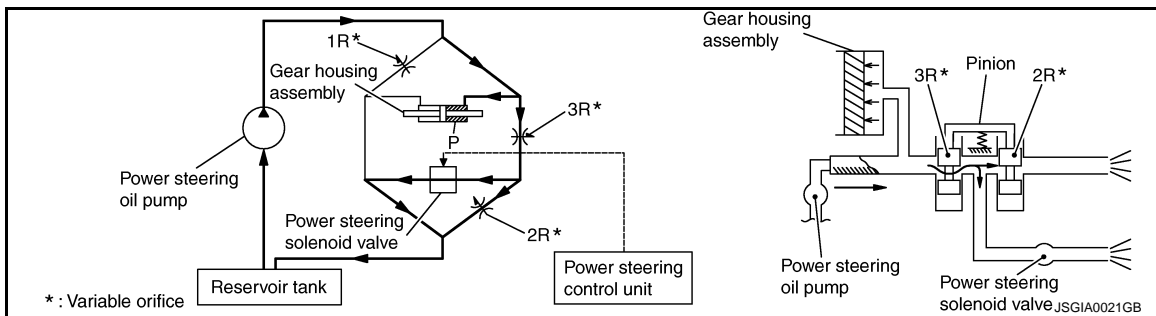

- Power steering solenoid valve is opened during high-speed operation.
- Pinion "1R", "2R" and "3R" are closed depending on steering torque of steering wheel.
- Oil pressure "2R" does not occur because the power steering solenoid valve is on full throttle.
- Oil pressure "P" in the gear housing assembly includes only oil pressure occurred in "3R" and results in a heavy steering force.

# EPS SYSTEM

< SYSTEM DESCRIPTION >

[WITHOUT REAR ACTIVE STEER]

## Component Parts Location

INFOID:000000003826285

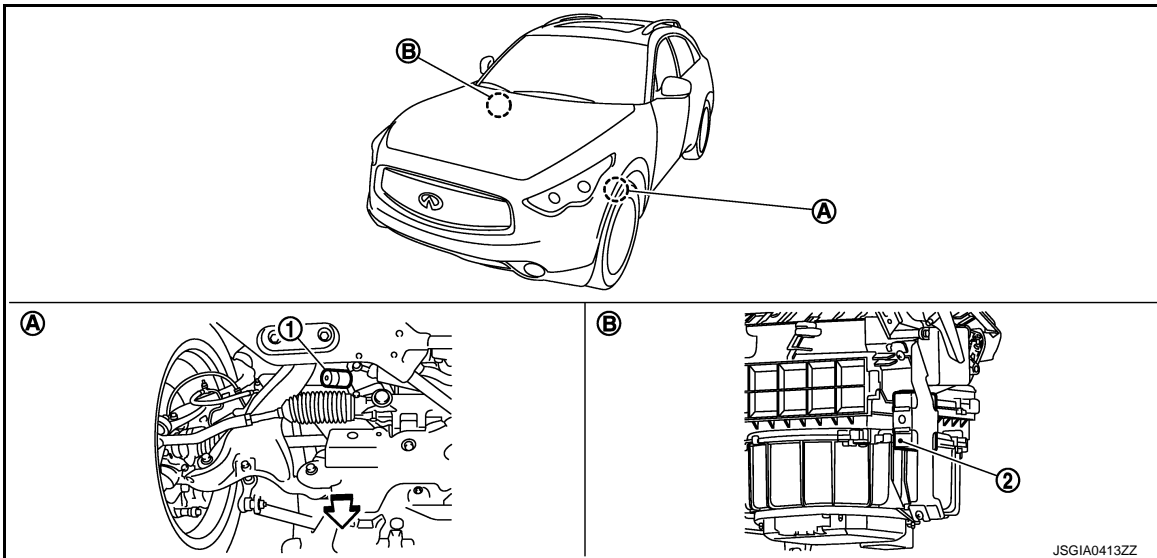

- 1. Power steering solenoid valve
- 2. Power steering control unit
- A. Steering gear assembly
- B. Glove box assembly removed

←: Vehicle front

## Component Description

INFOID:000000003826286

Component parts	Reference/Function
Power steering control unit	<ul style="list-style-type: none"> <li>• Signals from various sensors control the driving voltage to the power steering solenoid valve.</li> <li>• The power steering control unit controls the driving voltage to the power steering solenoid valve for maintaining the power steering assist force when the fail-safe function is activated. (The engine speed signals control EPS system if any vehicle speed signal error is detected.)</li> </ul>
Unified meter and A/C amp.	<a href="#">STC-14, "Description"</a>
ECM	<a href="#">STC-11, "Description"</a>
Power steering solenoid valve	<a href="#">STC-9, "Description"</a>

# POWER SUPPLY AND GROUND CIRCUIT

< DTC/CIRCUIT DIAGNOSIS >

[WITHOUT REAR ACTIVE STEER]

## DTC/CIRCUIT DIAGNOSIS

### POWER SUPPLY AND GROUND CIRCUIT

#### Description

INFOID:000000003826287

Power supply to EPS system

#### Diagnosis Procedure

INFOID:000000003826288

#### 1. CHECK POWER SUPPLY

1. Turn the ignition switch OFF.
2. Disconnect power steering control unit harness connector.
3. Check voltage between power steering control unit harness connector and ground.

Power steering control unit		—	Voltage
Connector	Terminal		
M108	3	Ground	0 V

4. Turn the ignition switch ON.  
**CAUTION:**  
**Never start the engine.**
5. Check voltage between power steering control unit harness connector and ground.

Power steering control unit		—	Voltage
Connector	Terminal		
M108	3	Ground	Battery voltage

#### Is the inspection result normal?

YES >> GO TO 2.

NO >> Check the following. If any items are damaged, repair or replace damaged parts.

- 10A fuses (#45) open
- Harness for short or open between ignition switch and power steering control unit harness connector No. 3 terminal.
- Ignition switch.

#### 2. CHECK GROUND CIRCUIT

1. Turn the ignition switch OFF.
2. Check continuity between power steering control unit harness connector and ground.

Power steering control unit		—	Continuity
Connector	Terminal		
M108	6	Ground	Existed

#### Is the inspection result normal?

YES >> GO TO 3.

NO >> Repair open circuit or short to power in harness or connectors.

#### 3. CHECK TERMINALS AND HARNESS CONNECTORS

Check power steering control unit pin terminals for damage or loose connection with harness connector.

#### Is the inspection result normal?

YES >> INSPECTION END

NO >> Repair or replace damaged parts.



# POWER STEERING SOLENOID VALVE

< DTC/CIRCUIT DIAGNOSIS >

[WITHOUT REAR ACTIVE STEER]

## POWER STEERING SOLENOID VALVE

### Description

INFOID:000000003826289

Power steering solenoid valve controls the power steering oil pressure in the gear housing assembly.

### Diagnosis Procedure

INFOID:000000003826290

#### 1. CHECK POWER STEERING SOLENOID VALVE SIGNAL

1. Turn the ignition switch OFF.
2. Check voltage between power steering control unit harness connector and ground.

Power steering control unit		—	Condition	Voltage (Approx.)
Connector	Terminal			
M108	1	Ground	Vehicle speed: 0 km/h (0 MPH) (Engine is running)	4.4 – 6.6 V
			Vehicle speed: 100 km/h (62 MPH)	2.4 – 3.6 V

Is the inspection result normal?

YES >> GO TO 2.

NO >> GO TO 4.

#### 2. CHECK HARNESS BETWEEN POWER STEERING SOLENOID VALVE AND POWER STEERING CONTROL UNIT

1. Turn the ignition switch OFF.
2. Disconnect power steering solenoid valve harness connector.
3. Disconnect power steering control unit harness connector.
4. Check the continuity between power steering solenoid valve harness connector and the power steering control unit harness connector.

Power steering solenoid valve		Power steering control unit		Continuity
Connector	Terminal	Connector	Terminal	
F45	1	M108	1	Existed
	2		5	Existed

5. Check continuity between power steering control unit harness connector and ground.

Power steering control unit		—	Continuity
Connector	Terminal		
M108	1	Ground	Not existed
	5		

Is the inspection result normal?

YES >> GO TO 3.

NO >> Repair or replace damaged parts.

#### 3. CHECK POWER STEERING SOLENOID VALVE

Check power steering solenoid valve. Refer to [STC-10, "Component Inspection"](#).

Is the inspection result normal?

YES >> GO TO 4.

NO >> Replace gear-sub assembly. Refer to [ST-25, "Exploded View"](#).

#### 4. CHECK TERMINALS AND HARNESS CONNECTORS

- Check power steering control unit pin terminals for damage or loose connection with harness connector.
- Check power steering solenoid valve pin terminals for damage or loose connection with harness connector.

Is the inspection result normal?

A  
B  
C  
D  
E  
F  
H  
I  
J  
K  
L  
M  
N  
O  
P

STC

# POWER STEERING SOLENOID VALVE

[WITHOUT REAR ACTIVE STEER]

< DTC/CIRCUIT DIAGNOSIS >

- YES >> INSPECTION END
- NO >> Repair or replace damaged parts.

## Component Inspection

INFOID:000000003826291

### 1. CHECK POWER STEERING SOLENOID VALVE

1. Turn the ignition switch OFF.
2. Disconnect power steering solenoid valve harness connector.
3. Check resistance between power steering solenoid valve connector terminals.

Power steering solenoid valve			Resistance (Approx.)
Connector	Terminal		
F45	1	2	4 – 6 Ω

4. Check power steering solenoid valve by listening for its operation sound while applying battery voltage to power steering solenoid valve connector F45 terminals 1 (positive) and 2 (negative).

Is the inspection result normal?

- YES >> INSPECTION END
- NO >> Replace gear-sub assembly. Refer to [ST-25, "Exploded View"](#).

# ENGINE SPEED SIGNAL CIRCUIT

< DTC/CIRCUIT DIAGNOSIS >

[WITHOUT REAR ACTIVE STEER]

## ENGINE SPEED SIGNAL CIRCUIT

### Description

INFOID:000000003826292

ECM sends engine speed signal to power steering control unit.

### Diagnosis Procedure

INFOID:000000003826293

#### 1. PERFORM ECM SELF-DIAGNOSIS

##### With CONSULT-III

1. Turn the ignition switch ON.
2. Perform ECM self-diagnosis. Refer to [EC-124. "CONSULT-III Function"](#) (VQ35HR), [EC-719. "CONSULT-III Function"](#) (VK50VE).

##### Is any DTC detected?

- YES >> Check the DTC.  
NO >> GO TO 2.

#### 2. CHECK HARNESS BETWEEN ECM AND POWER STEERING CONTROL UNIT

1. Turn the ignition switch OFF.
2. Disconnect ECM harness connectors.
3. Disconnect power steering control unit harness connector.
4. Check continuity between ECM harness connector and power steering control unit harness connector.

ECM		Power steering control unit		Continuity
Connector	Terminal	Connector	Terminal	
M107 (VQ engine)	110	M108	10	Existed
M160 (VK engine)	97			

5. Check continuity between power steering control unit harness connector and ground.

Power steering control unit		—	Continuity
Connector	Terminal		
M108	10	Ground	Not existed

##### Is the inspection result normal?

- YES >> GO TO 3.  
NO >> Repair or replace damaged parts.

#### 3. CHECK ENGINE SPEED SIGNAL (1)

1. Connect ECM harness connectors.
2. Check signal between ECM harness connector and ground with oscilloscope.

# ENGINE SPEED SIGNAL CIRCUIT

< DTC/CIRCUIT DIAGNOSIS >

[WITHOUT REAR ACTIVE STEER]

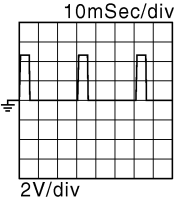
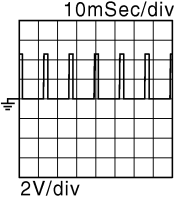
ECM		—	Condition	Voltage (Approx.)
Connector	Terminal			
M107 (VQ engine) M160 (VK engine)	110 (VQ engine) 97 (VK engine)	Ground	Engine is running • Warm-up condition • Idle speed	
			Engine is running • Warm-up condition • Engine speed: Approx. 2,000 rpm	

Is the inspection result normal?

YES >> GO TO 4.

NO >> Replace ECM. Refer to [EC-23, "ADDITIONAL SERVICE WHEN REPLACING CONTROL UNIT : Description"](#) (VQ engine), [EC-580, "ADDITIONAL SERVICE WHEN REPLACING CONTROL UNIT \(ECM\) : Description"](#) (VK engine).

## 4. CHECK ENGINE SPEED SIGNAL (2)

1. Turn the ignition switch OFF.
2. Connect power steering control unit harness connector.
3. Check signal between power steering control unit harness connector and ground with oscilloscope.

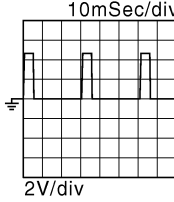
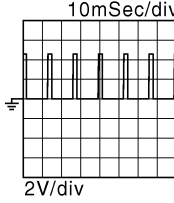
Power steering control unit		—	Condition	Voltage (Approx.)
Connector	Terminal			
M108	10	Ground	Engine is running • Warm-up condition • Idle speed	
			Engine is running • Warm-up condition • Engine speed: Approx. 2,000 rpm	

Is the inspection result normal?

YES >> GO TO 5.

NO >> Replace power steering control unit. Refer to [STC-25, "Exploded View"](#).

## 5. CHECK TERMINALS AND HARNESS CONNECTORS

- Check power steering control unit pin terminals for damage or loose connection with harness connector.
- Check ECM pin terminals for damage or loose connection with harness connector.

Is the inspection result normal?

YES >> INSPECTION END

# ENGINE SPEED SIGNAL CIRCUIT

< DTC/CIRCUIT DIAGNOSIS >

[WITHOUT REAR ACTIVE STEER]

NO >> Repair or replace damaged parts.

A

B

C

D

E

F

**STC**

H

I

J

K

L

M

N

O

P

# VEHICLE SPEED SIGNAL CIRCUIT

< DTC/CIRCUIT DIAGNOSIS >

[WITHOUT REAR ACTIVE STEER]

## VEHICLE SPEED SIGNAL CIRCUIT

### Description

INFOID:000000003826294

Unified meter and A/C amp. sends vehicle speed signal to power steering control unit.

### Diagnosis Procedure

INFOID:000000003826295

#### 1. PERFORM UNIFIED METER AND A/C AMP. SELF-DIAGNOSIS

##### With CONSULT-III

1. Turn the ignition switch ON.
2. Perform unified meter and A/C amp. self-diagnosis. Refer to [MWI-45. "CONSULT-III Function \(METER/M&A\)"](#).

##### Is any DTC detected?

- YES >> Check the DTC.  
NO >> GO TO 2.

#### 2. CHECK HARNESS BETWEEN UNIFIED METER AND A/C AMP. AND POWER STEERING CONTROL UNIT

1. Turn the ignition switch OFF.
2. Disconnect unified meter and A/C amp. harness connector.
3. Disconnect power steering control unit harness connector.
4. Check continuity between unified meter and A/C amp. harness connector and power steering control unit harness connector.

Unified meter and A/C amp.		Power steering control unit		Continuity
Connector	Terminal	Connector	Terminal	
M66	8	M108	8	Existed

5. Check continuity between power steering control unit harness connector and ground.

Power steering control unit		—	Continuity
Connector	Terminal		
M108	8	Ground	Not existed

##### Is the inspection result normal?

- YES >> GO TO 3.  
NO >> Repair or replace damaged parts.

#### 3. CHECK VEHICLE SPEED SIGNAL (1)

1. Connect unified meter and A/C amp. harness connector.
2. Check unified meter and A/C amp. input/output standard values. Refer to [MWI-93. "Reference Value"](#).

##### Is the inspection result normal?

- YES >> GO TO 4.  
NO >> Replace unified meter and A/C amp. Refer to [MWI-175. "Exploded View"](#).

#### 4. CHECK VEHICLE SPEED SIGNAL (2)

1. Turn the ignition switch OFF.
2. Connect power steering control unit harness connector.
3. Check signal between power steering control unit harness connector and ground with oscilloscope.

# VEHICLE SPEED SIGNAL CIRCUIT

< DTC/CIRCUIT DIAGNOSIS >

[WITHOUT REAR ACTIVE STEER]

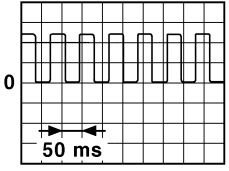
Power steering control unit		—	Condition	Voltage (Approx.)
Connector	Terminal			
M108	8	Ground	Vehicle speed: 40 km/h (25 MPH) <b>CAUTION:</b> Check air pressure of tire under standard condition.	<b>NOTE:</b> The maximum voltage varies depending on the specification (destination unit).  <small style="text-align: right;">JSNIA0015GB</small>

Is the inspection result normal?

YES >> GO TO 5.

NO >> Replace power steering control unit. Refer to [STC-25, "Exploded View"](#).

## 5. CHECK TERMINALS AND HARNESS CONNECTORS

- Check power steering control unit pin terminals for damage or loose connection with harness connector.
- Check unified meter and A/C amp. pin terminals for damage or loose connection with harness connector.

Is the inspection result normal?

YES >> INSPECTION END

NO >> Repair or replace damaged parts.

A  
B  
C  
D  
E  
F  
H  
I  
J  
K  
L  
M  
N  
O  
P

STC

# POWER STEERING CONTROL UNIT

< ECU DIAGNOSIS INFORMATION >

[WITHOUT REAR ACTIVE STEER]

## ECU DIAGNOSIS INFORMATION

### POWER STEERING CONTROL UNIT

Reference Value

INFOID:000000003826296

#### TERMINAL LAYOUT

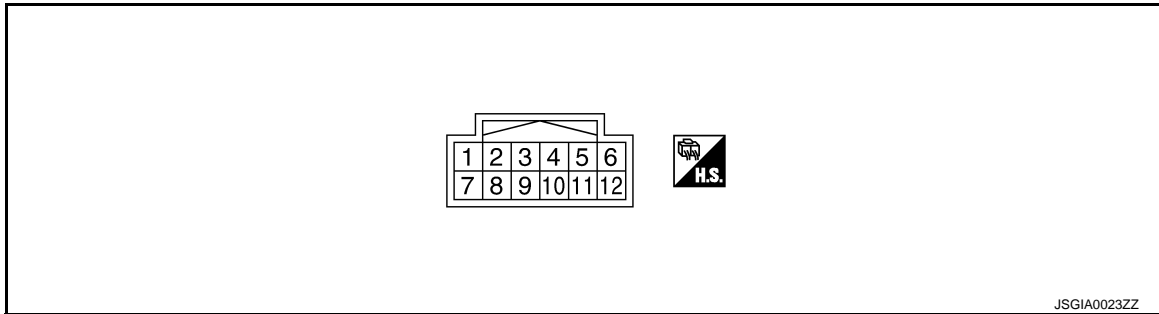

#### PHYSICAL VALUES

Terminal No. (Wire color)		Description		Condition	Value (Approx.)
+	-	Signal name	Input/ Output		
1 (LG)	Ground	Power steering solenoid valve voltage	Output	Vehicle speed: 0 km/h (0 MPH) (Engine is running)	4.4 – 6.6 V
				Vehicle speed: 100 km/h (62 MPH)	2.4 – 3.6 V
3 (G)	Ground	Ignition switch power supply	Input	Ignition switch: ON	Battery voltage
				Ignition switch: OFF	0 V
5 (B)	Ground	Power steering solenoid valve ground	—	Always	0 V
6 (B)	Ground	Ground	—	Always	0 V
8 (L)	Ground	Vehicle speed signal	Input	Vehicle speed: 40 km/h (25 MPH) <b>CAUTION:</b> Check air pressure of tire under standard condition.	<p><b>NOTE:</b> The maximum voltage varies depending on the specification (destination unit).</p> <p>The timing diagram shows a square wave pulse train on a grid. The horizontal axis is labeled '50 ms' and the vertical axis is labeled '0'. The pulses are approximately 10 ms wide and 10 ms apart.</p>

JSNIA0015GB



# POWER STEERING CONTROL UNIT

< ECU DIAGNOSIS INFORMATION >

[WITHOUT REAR ACTIVE STEER]

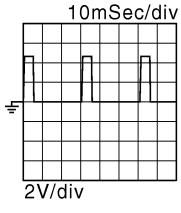
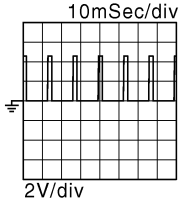
Terminal No. (Wire color)		Description		Condition	Value (Approx.)
+	-	Signal name	Input/ Output		
10 (R)	Ground	Engine speed signal	Input	Engine is running • Warm-up condition • Idle speed	
				Engine is running • Warm-up condition • Engine speed: Approx. 2,000 rpm	

**CAUTION:**

When using circuit tester or oscilloscope to measure voltage for inspection, be sure not to forcibly extend any connector terminals.

A  
B  
C  
D  
E  
F  
  
H  
I  
J  
K  
L  
M  
N  
O  
P

STC

# POWER STEERING CONTROL UNIT

< ECU DIAGNOSIS INFORMATION >

[WITHOUT REAR ACTIVE STEER]

## Wiring Diagram - ELECTRONICALLY CONTROLLED POWER STEERING SYSTEM -

INFOID:000000003826297

### ELECTRONICALLY CONTROLLED POWER STEERING SYSTEM

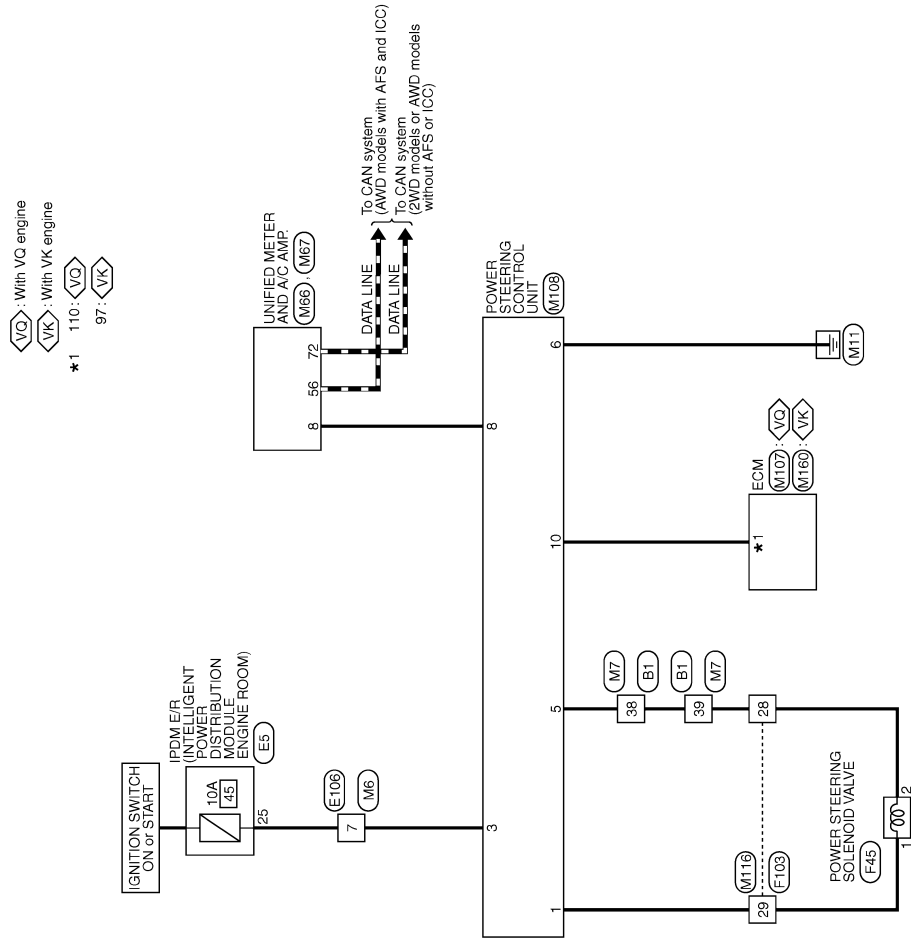

2008/03/04

JCGWM0104GB

# POWER STEERING CONTROL UNIT

< ECU DIAGNOSIS INFORMATION >

[WITHOUT REAR ACTIVE STEER]

## ELECTRONICALLY CONTROLLED POWER STEERING SYSTEM

Connector No.	B1
Connector Name	WIRE TO WIRE
Connector Type	TH80FW-CS16-TM4

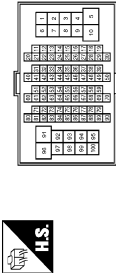

Terminal No.	38	B	Signal Name [Specification]
	39	B	

Connector No.	E5
Connector Name	EPDM E/R (INTELLIGENT POWER DISTRIBUTION MODULE ENGINE ROOM)
Connector Type	TH20FW-CS12-IM-TV



Terminal No.	25	G	Signal Name [Specification]
--------------	----	---	-----------------------------

Connector No.	E106
Connector Name	WIRE TO WIRE
Connector Type	TH80FW-CS16-TM4

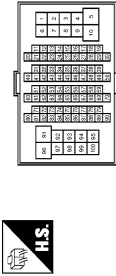

Terminal No.	7	G	Signal Name [Specification]
--------------	---	---	-----------------------------

Connector No.	F45
Connector Name	POWER STEERING SOLENOID VALVE
Connector Type	PS02FBR-DGY



Terminal No.	1	LG	Signal Name [Specification]
	2	B	EPS SOL+ EPS SOL-

Connector No.	F103
Connector Name	WIRE TO WIRE
Connector Type	TK38FW-NS10

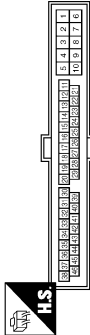

Terminal No.	28	B	Signal Name [Specification]
	29	LG	

Connector No.	M6
Connector Name	WIRE TO WIRE
Connector Type	TH80MW-CS16-TM4



Terminal No.	7	G	Signal Name [Specification]
--------------	---	---	-----------------------------

Connector No.	M7
Connector Name	WIRE TO WIRE
Connector Type	TH80MW-CS16-TM4

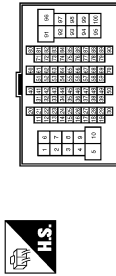

Terminal No.	38	B	Signal Name [Specification]
	39	B	

Connector No.	M66
Connector Name	UNIFIED METER AND A/C AMP.
Connector Type	TH40FW-NH

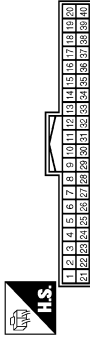

Terminal No.	8	L	Signal Name [Specification]
			VEHICLE SPEED (2-PULSE)

A  
B  
C  
D  
E  
F  
STC  
H  
I  
J  
K  
L  
M  
N  
O  
P

# POWER STEERING CONTROL UNIT

< ECU DIAGNOSIS INFORMATION >

[WITHOUT REAR ACTIVE STEER]

## ELECTRONICALLY CONTROLLED POWER STEERING SYSTEM

Connector No.	M67
Connector Name	UNIFIED METER AND A/C AMP.
Connector Type	TH32FW-NH

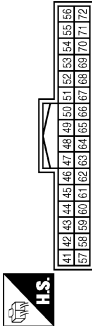

Terminal No.	Color of Wire	Signal Name [Specification]
56	L	CAN-H
72	P	CAN-L

Connector No.	M107
Connector Name	ECM (WITH VO ENGINE)
Connector Type	RH24FY-RZ8-R-LH-Z

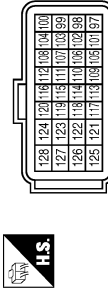

Terminal No.	Color of Wire	Signal Name [Specification]
110	R	TACHO

Connector No.	M108
Connector Name	POWER STEERING CONTROL UNIT
Connector Type	TH1ZFW-NH

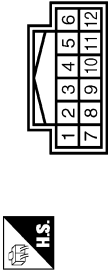

Terminal No.	Color of Wire	Signal Name [Specification]
1	LG	EPS SOL+
3	G	IGN
5	B	EPS SOL-
6	B	GND
8	L	VEHICLE SPEED(ZP)
10	R	ENG TACHO

Connector No.	M116
Connector Name	WIRE TO WIRE
Connector Type	TK38MW-NS10



Terminal No.	Color of Wire	Signal Name [Specification]
28	B	-
29	LG	-

Connector No.	M180
Connector Name	ECM (WITH VK ENGINE)
Connector Type	RH24FY-RZ8-R-LH-Z



Terminal No.	Color of Wire	Signal Name [Specification]
97	R	TACHO

Fail-Safe

EPS system

JCGWM0106GB

INFOID:000000003826298

# POWER STEERING CONTROL UNIT

## < ECU DIAGNOSIS INFORMATION >

## [WITHOUT REAR ACTIVE STEER]

- EPS system enters the fail-safe mode (that allows the steering force to be controlled without impairing the drivability) if any of the input/output values to/from EPS system (power steering control unit) deviate from the standard range.

**NOTE:**

The system enters the fail-safe mode if the engine speed remains at 1,500 rpm or more for over 10 seconds while the vehicle is stopped. This is normal.

- The fail-safe function is canceled when a vehicle speed signal of 2 km/h (1.2 MPH) or more is inputted or the ignition switch is turned OFF→ON. EPS system restores the normal operation at that time.

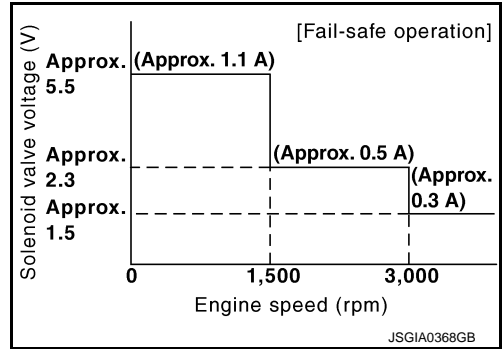

Mode	Warning lamp	DTC	Detection point (malfunction part)	Error area and root cause
Fail-safe	—	—	Vehicle speed signal input	<ul style="list-style-type: none"> <li>• Engine speed is 1,500 rpm or more and there is no vehicle speed signal input for over 10 seconds during vehicle travel.</li> <li>• Vehicle speed signal has abruptly dropped from 30 km/h (19 MPH) or more to 2 km/h (1.2 MPH) or less within 1.4 seconds.</li> </ul>

A  
B  
C  
D  
E  
F  
H  
I  
J  
K  
L  
M  
N  
O  
P

STC

# UNBALANCE STEERING WHEEL TURNING FORCE (TORQUE VARIATION)

< SYMPTOM DIAGNOSIS >

[WITHOUT REAR ACTIVE STEER]

## SYMPTOM DIAGNOSIS

### UNBALANCE STEERING WHEEL TURNING FORCE (TORQUE VARIATION)

#### Description

INFOID:000000003826299

- Hard steering when fully turning the steering wheel.
- Light steering when driving at a high speed.

#### Diagnosis Procedure

INFOID:000000003826300

#### 1. CHECK SYSTEM FOR POWER SUPPLY AND GROUND

Perform trouble diagnosis for power supply and ground. Refer to [STC-8, "Diagnosis Procedure"](#).

Is the inspection result normal?

- YES >> GO TO 2.
- NO >> Repair or replace damaged parts.

#### 2. CHECK SYSTEM FOR VEHICLE SPEED SIGNAL

Perform trouble diagnosis for vehicle speed signal. Refer to [STC-14, "Diagnosis Procedure"](#).

Is the inspection result normal?

- YES >> GO TO 3.
- NO >> Repair or replace damaged parts.

#### 3. CHECK SYSTEM FOR ENGINE SPEED SIGNAL

Perform trouble diagnosis for engine speed signal. Refer to [STC-11, "Diagnosis Procedure"](#).

Is the inspection result normal?

- YES >> GO TO 4.
- NO >> Repair or replace damaged parts.

#### 4. CHECK SYSTEM FOR POWER STEERING SOLENOID VALVE

Perform trouble diagnosis for power steering solenoid valve. Refer to [STC-9, "Diagnosis Procedure"](#).

Is the inspection result normal?

- YES >> Perform the symptom diagnosis for the steering system. Refer to [ST-3, "NVH Troubleshooting Chart"](#).
- NO >> Repair or replace damaged parts.

PRECAUTION

PRECAUTIONS

Precaution for Supplemental Restraint System (SRS) "AIR BAG" and "SEAT BELT PRE-TENSIONER"

INFOID:000000004166515

The Supplemental Restraint System such as "AIR BAG" and "SEAT BELT PRE-TENSIONER", used along with a front seat belt, helps to reduce the risk or severity of injury to the driver and front passenger for certain types of collision. This system includes seat belt switch inputs and dual stage front air bag modules. The SRS system uses the seat belt switches to determine the front air bag deployment, and may only deploy one front air bag, depending on the severity of a collision and whether the front occupants are belted or unbelted. Information necessary to service the system safely is included in the "SRS AIR BAG" and "SEAT BELT" of this Service Manual.

**WARNING:**

- To avoid rendering the SRS inoperative, which could increase the risk of personal injury or death in the event of a collision which would result in air bag inflation, all maintenance must be performed by an authorized NISSAN/INFINITI dealer.
- Improper maintenance, including incorrect removal and installation of the SRS, can lead to personal injury caused by unintentional activation of the system. For removal of Spiral Cable and Air Bag Module, see the "SRS AIR BAG".
- Do not use electrical test equipment on any circuit related to the SRS unless instructed to in this Service Manual. SRS wiring harnesses can be identified by yellow and/or orange harnesses or harness connectors.

PRECAUTIONS WHEN USING POWER TOOLS (AIR OR ELECTRIC) AND HAMMERS

**WARNING:**

- When working near the Air Bag Diagnosis Sensor Unit or other Air Bag System sensors with the ignition ON or engine running, DO NOT use air or electric power tools or strike near the sensor(s) with a hammer. Heavy vibration could activate the sensor(s) and deploy the air bag(s), possibly causing serious injury.
- When using air or electric power tools or hammers, always switch the ignition OFF, disconnect the battery, and wait at least 3 minutes before performing any service.

Precaution Necessary for Steering Wheel Rotation after Battery Disconnect

INFOID:000000004166517

**NOTE:**

- Before removing and installing any control units, first turn the push-button ignition switch to the LOCK position, then disconnect both battery cables.
- After finishing work, confirm that all control unit connectors are connected properly, then re-connect both battery cables.
- Always use CONSULT-III to perform self-diagnosis as a part of each function inspection after finishing work. If a DTC is detected, perform trouble diagnosis according to self-diagnosis results.

This vehicle is equipped with a push-button ignition switch and a steering lock unit.

If the battery is disconnected or discharged, the steering wheel will lock and cannot be turned.

If turning the steering wheel is required with the battery disconnected or discharged, follow the procedure below before starting the repair operation.

OPERATION PROCEDURE

1. Connect both battery cables.

**NOTE:**

Supply power using jumper cables if battery is discharged.

2. Turn the push-button ignition switch to ACC position.  
(At this time, the steering lock will be released.)
3. Disconnect both battery cables. The steering lock will remain released with both battery cables disconnected and the steering wheel can be turned.
4. Perform the necessary repair operation.

## PRECAUTIONS

< PRECAUTION >

[WITHOUT REAR ACTIVE STEER]

---

5. When the repair work is completed, re-connect both battery cables. With the brake pedal released, turn the push-button ignition switch from ACC position to ON position, then to LOCK position. (The steering wheel will lock when the push-button ignition switch is turned to LOCK position.)
6. Perform self-diagnosis check of all control units using CONSULT-III.



# POWER STEERING CONTROL UNIT

< REMOVAL AND INSTALLATION >

[WITHOUT REAR ACTIVE STEER]

## REMOVAL AND INSTALLATION

### POWER STEERING CONTROL UNIT

Exploded View

INFOID:000000003826303

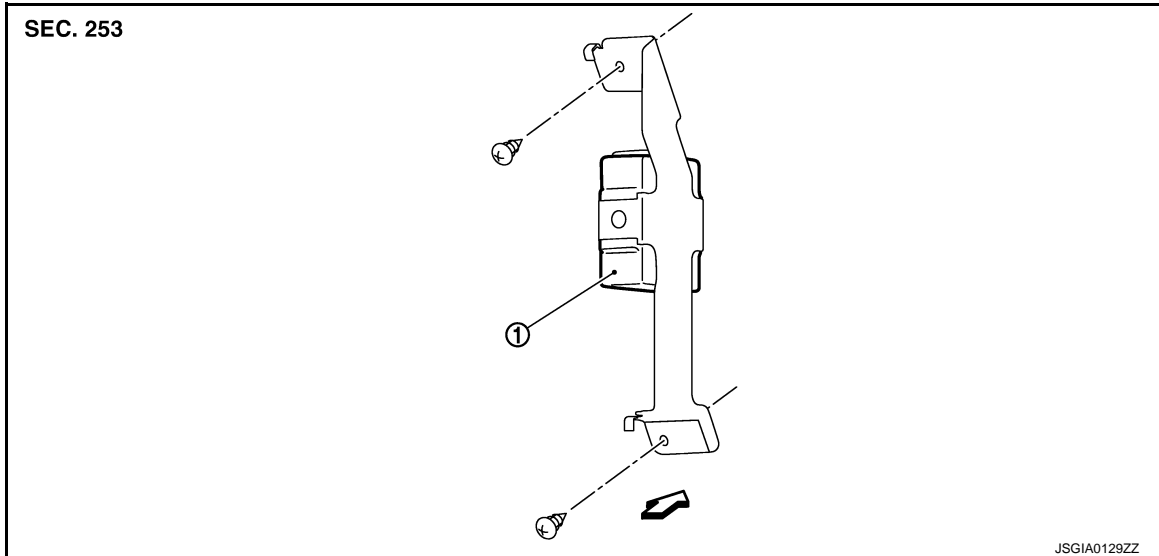

1. Power steering control unit

←: Vehicle front

### Removal and Installation

INFOID:000000003826304

#### REMOVAL

1. Remove instrument lower cover. Refer to [IP-11, "Exploded View"](#).
2. Remove instrument lower panel RH. Refer to [IP-11, "Exploded View"](#).
3. Remove power steering control unit screws.
4. Remove power steering control unit (1).
5. Disconnect power steering control unit connector.

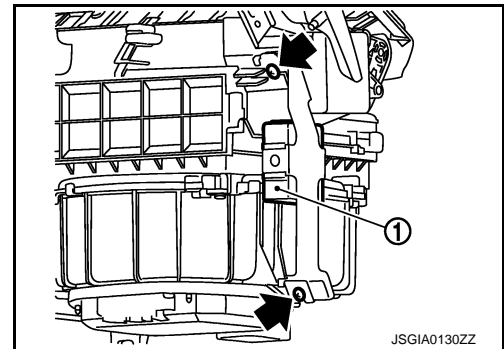

#### INSTALLATION

Install in the reverse order of removal.

A  
B  
C  
D  
E  
F  
STC  
H  
I  
J  
K  
L  
M  
N  
O  
P

## BASIC INSPECTION

### DIAGNOSIS AND REPAIR WORKFLOW

#### Work Flow

INFOID:000000003826305

#### DETAILED FLOW

#### 1. INTERVIEW FROM THE CUSTOMER

It is also important to clarify customer complaints before inspection. First of all, reproduce symptoms, and understand them fully. Ask customer about his/her complaints carefully. In some cases, it is necessary to check symptoms by driving vehicle with customer.

**CAUTION:**

**Customers are not professional. It is dangerous to make an easy guess like “maybe the customer means that...,” or “maybe the customer mentions this symptom”.**

>> GO TO 2.

#### 2. CHECK SYMPTOM

Start the engine.

**CAUTION:**

**Stop the vehicle.**

Does RAS warning lamp turn ON?

- YES >> GO TO 3.
- NO >> GO TO 5.

#### 3. PERFORM SELF-DIAGNOSIS

 **With CONSULT-III**

Perform RAS control unit self-diagnosis.

Is any DTC detected?

- YES >> GO TO 4.
- NO >> GO TO 5.

#### 4. PERFORM TROUBLE DIAGNOSIS

 **With CONSULT-III**

1. Check the error system detected from the self-diagnosis.

**CAUTION:**

**Check the “DATA MONITOR” value of each DTC detected with the self-diagnosis function.**

2. Erase RAS control unit self-diagnosis memory.

**CAUTION:**

- **Never erase the self-diagnosis result (record) history when replacing RAS control unit.**
- **Erase the memory of the self-diagnosis results (record) after printing out or recording all the values of “DATA MONITOR”.**

>> GO TO 5.

#### 5. CHECK TERMINAL

Check each harness connector pin terminal for disconnection.

>> GO TO 6.

#### 6. CHECK SYMPTOM REPRODUCTION

 **With CONSULT-III**

Perform DTC reproduction procedure for the error system.

Is any DTC detected?

- YES >> GO TO 2.
- NO >> GO TO 7.

# DIAGNOSIS AND REPAIR WORKFLOW

< BASIC INSPECTION >

[WITH REAR ACTIVE STEER]

## 7. PERFORM SYMPTOM DIAGNOSIS

### With CONSULT-III

Perform the symptom diagnosis for each system.

Is any error detected?

YES >> GO TO 2.

NO >> GO TO 8.

## 8. FINAL CHECK

### With CONSULT-III

Check input/output signal standard of RAS control unit.

Is the input/output the standard value?

YES >> INSPECTION END

NO >> GO TO 2.

A  
B  
C  
D  
E  
F  
H  
I  
J  
K  
L  
M  
N  
O  
P

STC

## SYSTEM DESCRIPTION

### RAS SYSTEM

#### System Diagram

INFOID:000000003826312

#### CONTROL DIAGRAM

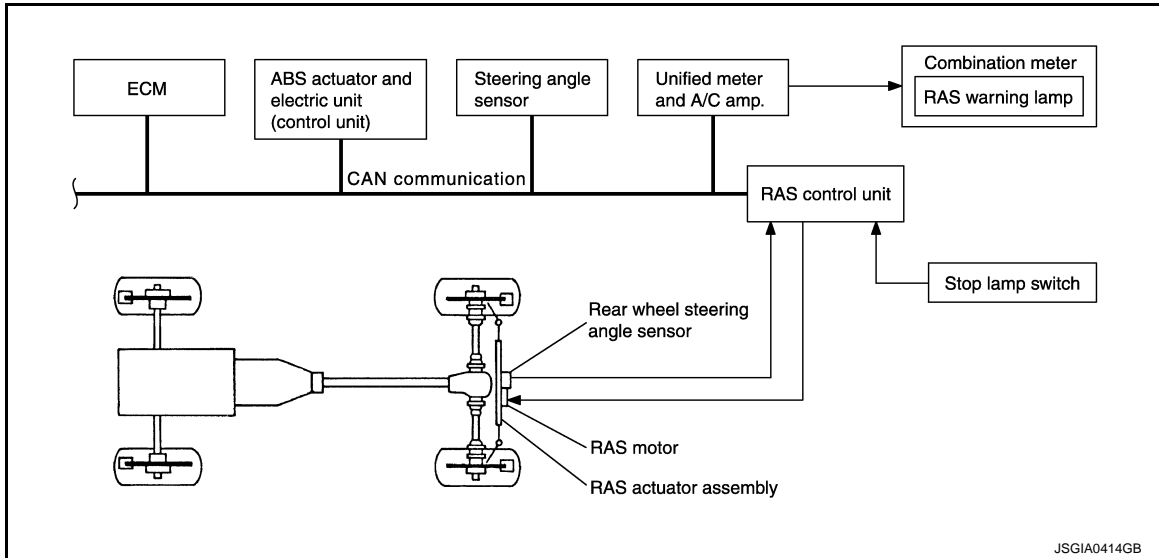

#### CROSS-SECTIONAL VIEW

#### RAS Actuator

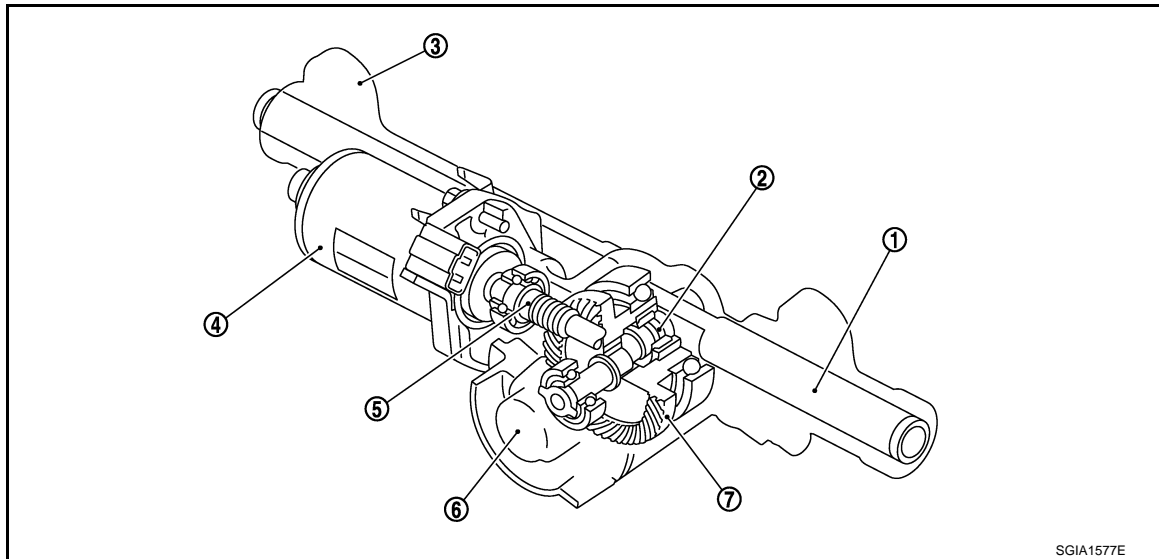

- |              |                 |                                     |
|--------------|-----------------|-------------------------------------|
| 1. Rod       | 2. Offset shaft | 3. Gear housing assembly            |
| 4. RAS motor | 5. Motor shaft  | 6. Rear wheel steering angle sensor |
| 7. HRH gear  |                 |                                     |

#### System Description

INFOID:000000003840920

#### DESCRIPTION

- RAS control unit controls the rear active steer.
- RAS system consists of RAS control unit and RAS actuator components.
- RAS control unit controls the RAS actuator assembly according to the steering angle and vehicle speed.
- Self-diagnosis can be performed with CONSULT-III at each control unit to another RAS control unit.

# RAS SYSTEM

[WITH REAR ACTIVE STEER]

## < SYSTEM DESCRIPTION >

- It transmits/receives each signal from the following control unit via CAN communication line.

Component parts	Function
Steering angle sensor	It mainly transmits the following signals to RAS control unit via CAN communication. <ul style="list-style-type: none"> <li>Steering angle sensor signal</li> </ul>
ABS actuator and electronic unit (control unit)	It mainly transmits the following signals to RAS control unit via CAN communication. <ul style="list-style-type: none"> <li>Vehicle speed signal</li> <li>VDC malfunction signal</li> </ul>
ECM	It mainly transmits the following signals to RAS control unit via CAN communication. <ul style="list-style-type: none"> <li>Engine speed signal</li> </ul>
Unified meter and A/C amp.	It mainly transmits the following signals from RAS control unit via CAN communication. <ul style="list-style-type: none"> <li>RAS warning lamp signal</li> </ul>

### Model Following Control

- Situation [A]:**  
The rear wheels turn to the opposite phase of front wheels for a moment so as to improve the start-up of yaw rate (steering angle speed).
- Situation [B]:**  
The rear wheels turn to the same phase of front wheels after securing the necessary yaw rate (steering angle speed) to cornering.

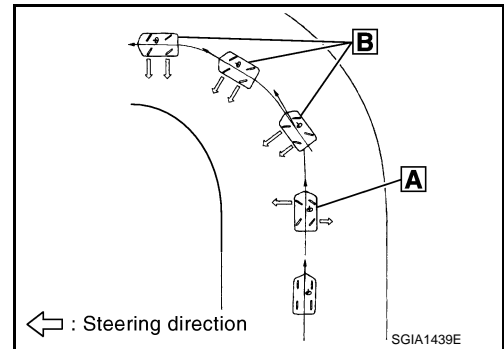

### OPERATION DESCRIPTION

The rear wheel angle changes as per the following:

#### During high-speed driving

- The rear wheels turn to the same phase of front wheels regardless of the operation speed of steering wheel.

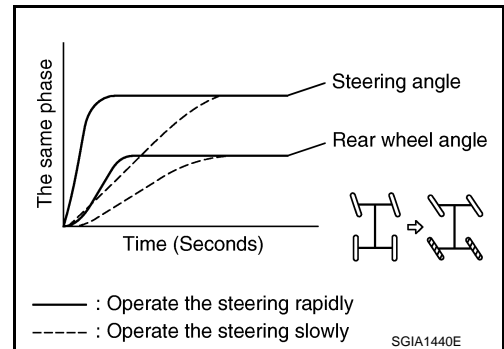

#### During middle- low-speed driving

- When turning the steering wheel rapidly, the rear wheels turn to the opposite phase of front wheels for a moment just after starting the steering wheel operation. And then, they turn to the same phase.

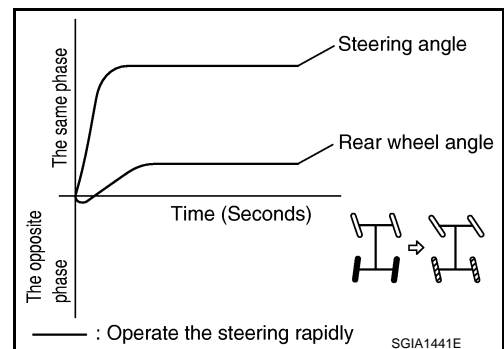

# RAS SYSTEM

## < SYSTEM DESCRIPTION >

[WITH REAR ACTIVE STEER]

- The rear wheels turn to the same phase of front wheels when turning the steering wheel slowly.

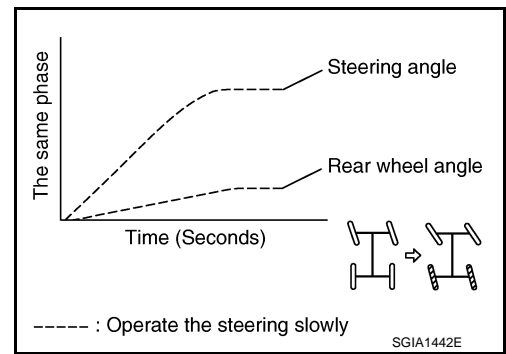

### During extremely slow-speed driving and at straight-ahead driving

- The rear wheels do not turn during extremely slow-speed driving regardless of the operation speed of steering wheel.
- The rear wheels do not turn at straight-ahead driving regardless of the vehicle speed.

## OPERATION FEATURE

### RAS ACTUATOR

- It is driven by RAS motor.
- The irreversible efficiency performance hypoid gear secures the toe-stiffness of rear wheels against the road external force and keep the steering angle when system is malfunction.
- The power from the pinion gear (motor side) is transmitted, but the pinion gear does not rotate as caused by the gear mechanical characteristics (teeth angle) even though the ring gear (tire side) starts to rotate.

## Component Parts Location

INFOID:000000003826314

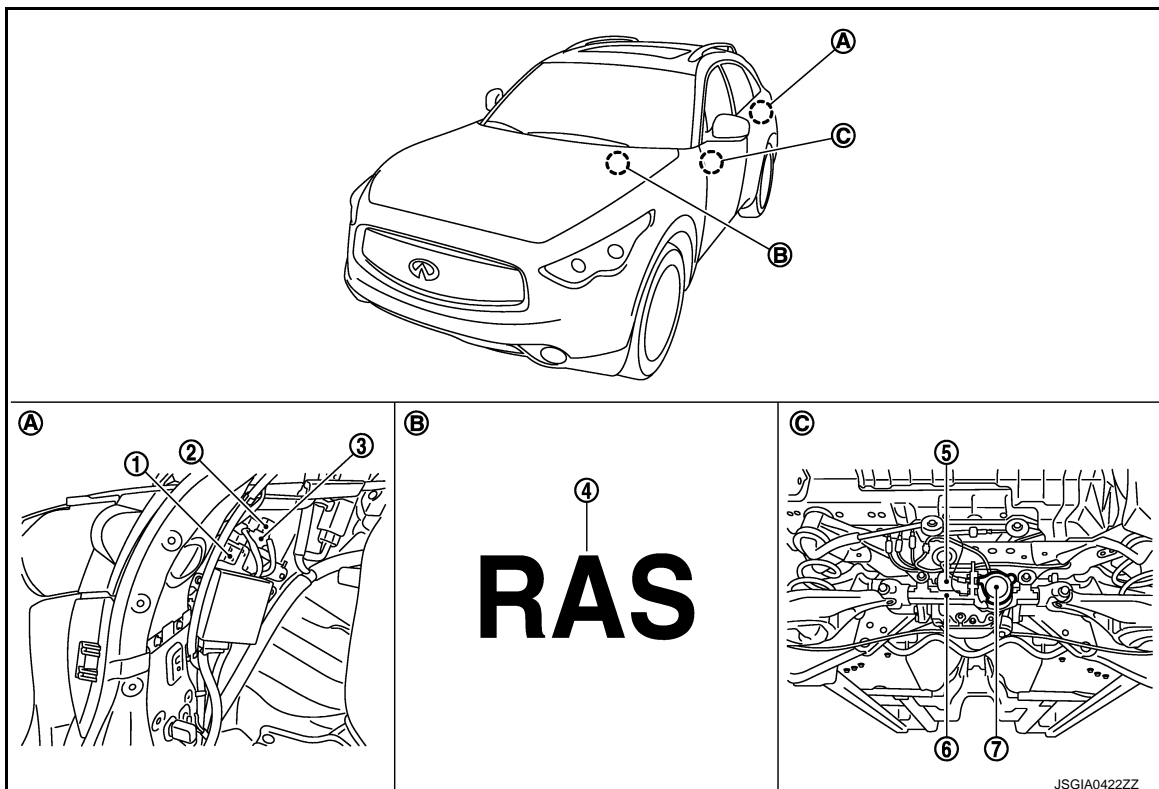

- |  |                             |                               |
|--|-----------------------------|-------------------------------|
| 1. RAS control unit                            | 2. RAS motor relay          | 3. Noise suppressor           |
| 4. RAS warning lamp                            | 5. RAS rear motor           | 6. RAS rear actuator          |
| 7. Rear wheel steering angle sensor            |                             |                               |
| A. Inside the rear wheel house finisher (left) | B. Inside combination meter | C. RAS rear actuator assembly |

# RAS SYSTEM

[WITH REAR ACTIVE STEER]

< SYSTEM DESCRIPTION >

## Component Description

INFOID:000000003826315

Component parts	Reference/Function
Steering angle sensor	<a href="#">STC-64, "Description"</a>
RAS control unit	<a href="#">STC-38, "Description"</a>
RAS actuator	The rear wheel steering angle is activated.
Rear wheel steering angle sensor	<a href="#">STC-53, "Description"</a>
RAS motor	<a href="#">STC-40, "Description"</a>
ABS actuator and electronic unit (control unit)	<a href="#">STC-62, "Description"</a>
ECM	<a href="#">STC-66, "Description"</a>
Power steering solenoid valve	<a href="#">STC-82, "Description"</a>
RAS warning lamp	<a href="#">STC-84, "Description"</a>
Stop lamp switch	The stop lamp switch condition is detected.

A  
B  
C  
D  
E  
F

STC

H  
I  
J  
K  
L  
M  
N  
O  
P

# EPS SYSTEM

[WITH REAR ACTIVE STEER]

< SYSTEM DESCRIPTION >

## EPS SYSTEM

### System Diagram

INFOID:000000003845426

### CONTROL DIAGRAM

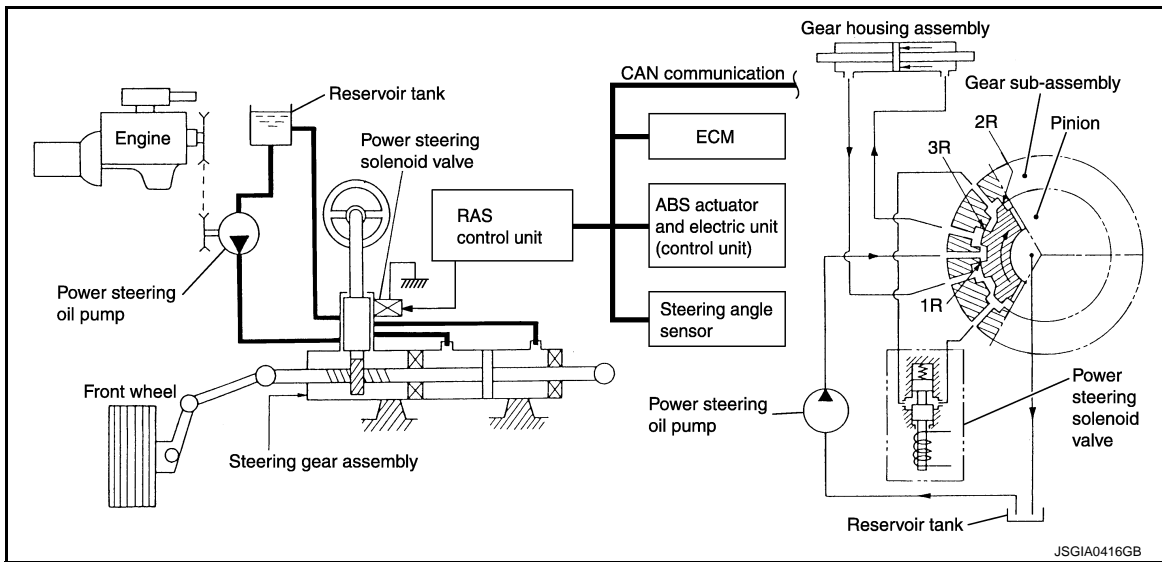

### CROSS-SECTIONAL VIEW

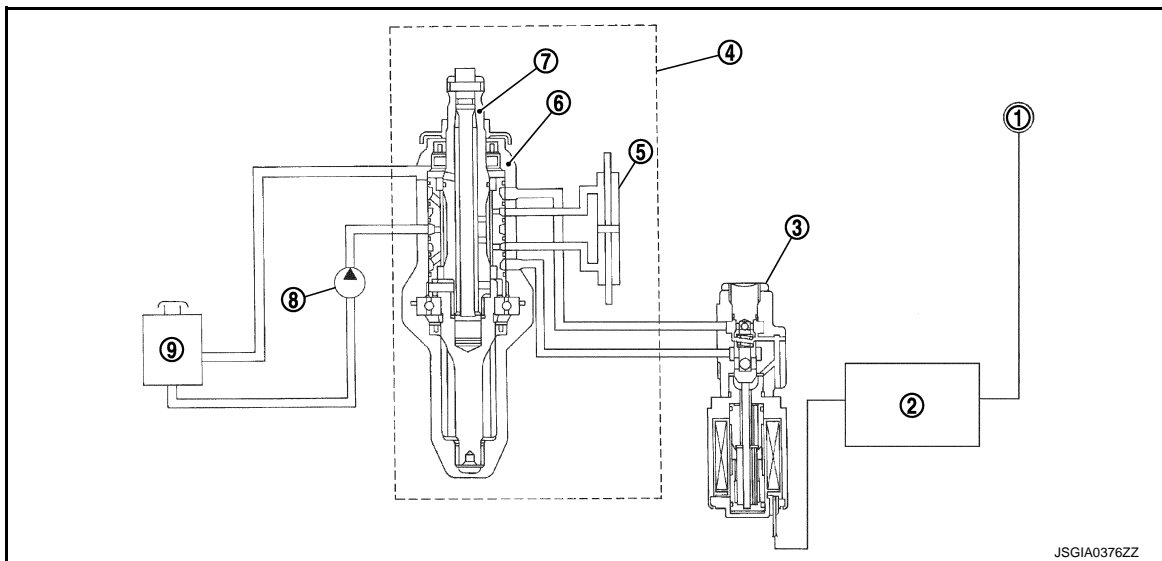

- |                               |                            |                                  |
|-------------------------------|----------------------------|----------------------------------|
| 1. Unified meter and A/C amp. | 2. RAS control unit        | 3. Power steering solenoid valve |
| 4. Steering gear assembly     | 5. Gear housing assembly   | 6. Gear sub-assembly             |
| 7. Pinion                     | 8. Power steering oil pump | 9. Reservoir tank                |

### System Description

INFOID:000000003845427

- The EPS system controls the power steering solenoid valve through the RAS control unit.



# EPS SYSTEM

## < SYSTEM DESCRIPTION >

[WITH REAR ACTIVE STEER]

- The valve driving voltage to control the power steering solenoid valve varies according to the vehicle speed.

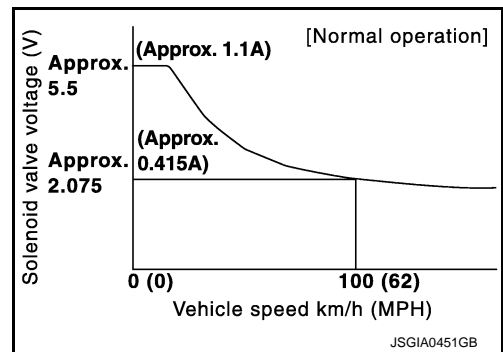

## OPERATION PRINCIPLE

During Parking (When Turning The Steering Wheel To The Right.)

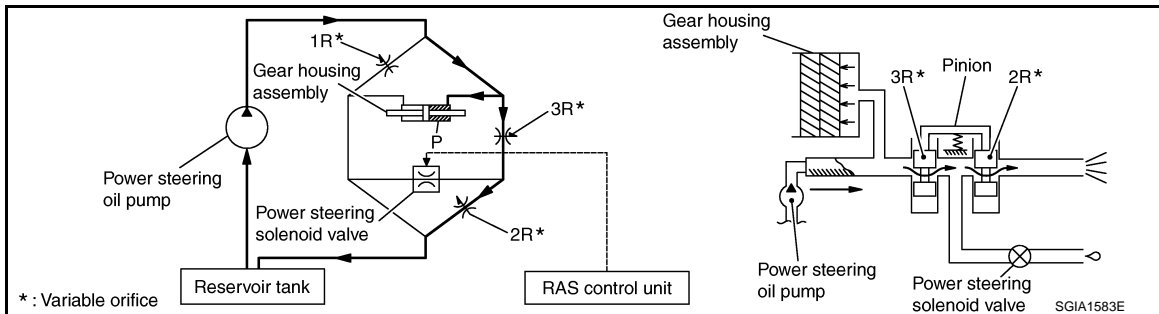

- Power steering solenoid valve is closed while a vehicle is stopped.
- Pinion "1R", "2R" and "3R" are closed depending on steering torque of steering wheel.
- Oil pressure "P" in the gear housing assembly is the sum of oil pressures occurred in "2R" and "3R". This results in a light steering force because of high pressure.

During High-speed Operation

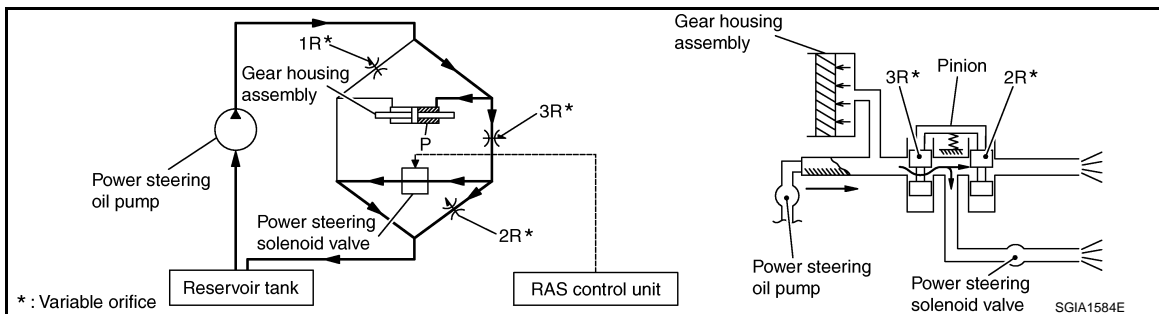

- Power steering solenoid valve is opened during high-speed operation.
- Pinion "1R", "2R" and "3R" are closed depending on steering torque of steering wheel.
- Oil pressure "2R" does not occur because the power steering solenoid valve is on full throttle.
- Oil pressure "P" in the gear housing assembly includes only oil pressure occurred in "3R" and results in a heavy steering force.

# EPS SYSTEM

[WITH REAR ACTIVE STEER]

< SYSTEM DESCRIPTION >

## Component Parts Location

INFOID:000000003861782

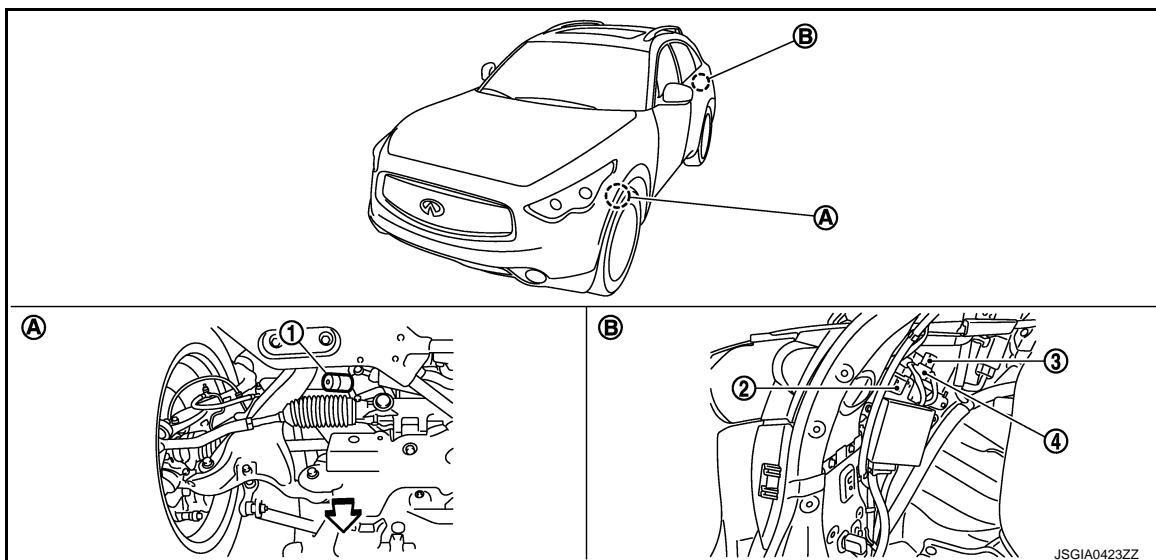

- |                                  |  |                    |
|----------------------------------|--|--------------------|
| 1. Power steering solenoid valve | 2. RAS control unit                            | 3. RAS motor relay |
| 4. Noise suppressor              |  |                    |
| A. Steering gear assembly        | B. Inside the rear wheel house finisher (Left) |                    |

↶: Vehicle front

## Component Description

INFOID:000000003845430

Component parts	Reference/Function
RAS control unit	<ul style="list-style-type: none"> <li>The power steering solenoid valve activation voltage is controlled by each sensor signal.</li> <li>The power steering solenoid valve activation voltage is controlled by RAS control unit for maintaining the power steering force in the fail-safe mode. (EPS system is controlled by the engine speed signal if the vehicle speed signal error is detected.)</li> </ul>
ABS actuator and electric unit (control unit)	<a href="#">STC-62. "Description"</a>
ECM	<a href="#">STC-66. "Description"</a>
Power steering solenoid valve	<a href="#">STC-82. "Description"</a>

# DIAGNOSIS SYSTEM (RAS CONTROL UNIT)

< SYSTEM DESCRIPTION >

[WITH REAR ACTIVE STEER]

## DIAGNOSIS SYSTEM (RAS CONTROL UNIT)

### Diagnosis Description

INFOID:000000003841897

#### DESCRIPTION

The RAS warning lamp in the combination meter will flicker according to the self-diagnostic results. As for the details of the RAS warning lamp flickering patterns.

#### DIAGNOSTIC PROCEDURE

1. Start the engine.
2. Perform the following procedure within 10 seconds after engine start.
  - Turn steering wheel left and right at 20° or more and 5 times
  - Depress the brake pedal 5 times or more
3. Read the flickering of RAS warning lamp.

**NOTE:**

When the RAS warning lamp flashes 4 Hz and continues repeating it, the system is normal.

#### JUDGMENT SELF-DIAGNOSIS CODE

When a malfunction is detected, the malfunction route is indicated by flickering of the RAS warning lamp.

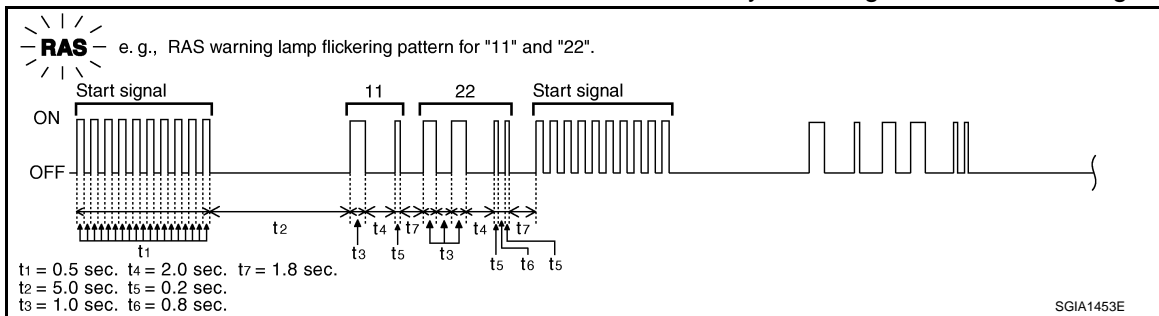

**NOTE:**

When the RAS warning lamp flashes 4 Hz and continues repeating it, the system is normal.

Flickering pattern	Display items	Malfunction detected condition	Check item
11	RAS control unit	Malfunction has occurred inside RAS control unit.	<a href="#">STC-38</a> , <a href="#">STC-44</a> or <a href="#">STC-46</a>
12	Motor power supply	Battery voltage circuit malfunction of RAS motor	<a href="#">STC-48</a>
13	Motor output	When the RAS motor current value is 10 A or more, actual output is excessively low and the condition continues for some time.	<a href="#">STC-40</a>
21	Vehicle speed signal	<ul style="list-style-type: none"> <li>• Malfunction is detected in vehicle speed signal that is output from ABS actuator and electric unit (control unit) via CAN communication.</li> <li>• Improper signal is input vehicle speed.</li> </ul>	<a href="#">STC-62</a>
22	Steering angle sensor signal	<ul style="list-style-type: none"> <li>• Malfunction is detected in steering angle sensor signal that is output from steering angle sensor via CAN communication.</li> <li>• Improper signal is input steering angle sensor.</li> </ul>	<a href="#">STC-64</a> , <a href="#">STC-68</a> , <a href="#">STC-70</a> or <a href="#">STC-72</a>
24	Rear wheel steering angle (main)	<ul style="list-style-type: none"> <li>• The rear wheel steering angle sensor (main) output signal is malfunctioning.</li> <li>• The rear wheel steering angle sensor (main) power supply value is malfunction.</li> <li>• The output signal value differs between rear wheel steering angle sensor (main) and (sub).</li> </ul>	<a href="#">STC-53</a> , <a href="#">STC-56</a> or <a href="#">STC-59</a>
25	Rear wheel steering angle (sub)	<ul style="list-style-type: none"> <li>• The rear wheel steering angle sensor (sub) output signal is malfunctioning.</li> <li>• The rear wheel steering angle sensor (sub) power supply value is malfunction.</li> <li>• The output signal value differs between rear wheel steering angle sensor (main) and (sub).</li> </ul>	<a href="#">STC-53</a> , <a href="#">STC-56</a> or <a href="#">STC-59</a>

# DIAGNOSIS SYSTEM (RAS CONTROL UNIT)

[WITH REAR ACTIVE STEER]

## < SYSTEM DESCRIPTION >

Flickering pattern	Display items	Malfunction detected condition	Check item
26	VDC	<ul style="list-style-type: none"> <li>Malfunction is detected in VDC malfunction signal that is output from ABS actuator and electric unit (control unit) via CAN communication.</li> <li>ABS actuator and electric unit (control unit) outputs the malfunction signal.</li> <li>Improper signal is input VDC malfunction signal.</li> </ul>	<a href="#">STC-74</a>
33	Engine speed signal	<ul style="list-style-type: none"> <li>Malfunction is detected in engine speed signal that is output from ECM via CAN communication.</li> <li>Improper signal is input engine speed.</li> </ul>	<a href="#">STC-66</a>
No flickering	Stop lamp switch	Stop lamp switch circuit is shorted or open.	<a href="#">STC-86</a>

### ERASE SELF-DIAGNOSIS

- In order to make it easier to find the cause of hard-to-duplicate malfunctions, malfunction information is stored into the control unit as necessary during use by the user. This memory is not erased no matter how many times the ignition switch is turned ON and OFF.
- However, this information is erased or by erasing the memory using the CONSULT-III.

### CONSULT-III Function

INFOID:000000003826321

#### FUNCTION

CONSULT-III can display each diagnostic item using the diagnostic test modes shown below.

Diagnostic test mode	Function
ECU identification	RAS control unit part number can be read.
Self-diagnostic results	Self-diagnostic results can be read and erased quickly.
Data monitor	Input/Output data in the RAS control unit can be read.
Active test	Diagnostic Test Mode in which CONSULT-III drives some actuators apart from the RAS control unit and also shifts some parameters in a specified range.

### SELF-DIAG RESULT MODE

Display Item List

Refer to [STC-98. "DTC Index"](#).

### DATA MONITOR MODE

Display Item List

Monitor item (Unit)	Remarks
VHCL SPEED SE [km/h] or [mph]	The vehicle speed signal from ABS actuator and electric unit (control unit) is indicated via CAN communication line.
STEERING ANG [°]	The steering angle sensor signal from the steering angle sensor is indicated via CAN communication line.
ENGINE SPEED [rpm]	The engine speed signal from ECM is indicated via CAN communication line.
POWER STR SOL [A]	The current value of the power steering solenoid valve is indicated.
RR ST ANG-MAI [V]	The voltage of the rear wheel steering angle sensor (main) is indicated.
RR ST ANG-SUB [V]	The voltage of the rear wheel steering angle sensor (sub) is indicated.
RR ST ANG-VOL [V]	The power supply voltage of the rear wheel steering angle sensor is indicated.
C/U VOLTAGE [V]	The power supply voltage value of RAS control unit is indicated.
MOTOR VOLTAGE [V]	The voltage value of RAS motor is indicated.
MOTOR CURRENT [A]	The current value of RAS motor is indicated.
MTR CRNT OPE [A]	The current value input to RAS motor is indicated.
RR ANGLE OPE [°]	The angle command value is indicated for activating RAS motor.

# DIAGNOSIS SYSTEM (RAS CONTROL UNIT)

[WITH REAR ACTIVE STEER]

< SYSTEM DESCRIPTION >

Monitor item (Unit)	Remarks
STOP LAMP SW [On/Off]	The stop lamp switch status is indicated.
HICAS RELAY [On/Off]	RAS motor relay condition is indicated.
FAILSAFE [On/Off]	The fail-safe mode status of RAS control unit is indicated.
WARNING LAMP [On/Off]	RAS warning lamp ON/OFF condition is indicated.

## ACTIVE TEST MODE

Description

- RAS actuator assembly activation is checked according to the control signal from CONSULT-III.
- The control signal forcibly activates (ON/OFF) RAS actuator assembly, performs the self-diagnosis and checks each sensor in "SELF DIAGNOSTIC MODE".

**CAUTION:**

**Perform the active test while the vehicle is stopped.**

Select test item	Control signal	Remarks
SELF DIAGNOSTIC MODE	ON <b>CAUTION:</b> <b>Perform the active test while the vehicle is stopped.</b>	RAS actuator assembly activates. It activates in the same direction as the steering angle by inputting the steering angle.
	OFF	RAS actuator assembly stops the activation.

Standard value

Monitor item	Active test "ON"		
	0° (Neutral)	R 90°	L 90°
STEERING ANG	0° (Neutral)	R 90°	L 90°
RR ST ANG-MAI	2.4 V	Approx. 4.4 V	Approx. 0.4 V
RR ST ANG-SUB	2.4 V	Approx. 4.4 V	Approx. 0.4 V
MOTOR CURRENT	No output (Approx. 0 A)	Output (change)	

# C1900, C1901, C1906, C1907, C1927 RAS CONTROL UNIT

< DTC/CIRCUIT DIAGNOSIS >

[WITH REAR ACTIVE STEER]

## DTC/CIRCUIT DIAGNOSIS

### C1900, C1901, C1906, C1907, C1927 RAS CONTROL UNIT

#### Description

INFOID:000000003826404

- RAS actuator and the power steering solenoid valve is controlled by each sensor signal.
- The fail-safe function stops the rear wheel angle function, when the electric components and the mechanical components are malfunctioning.
- The protective function stops RAS system temporarily when the input signal is not inputted to RAS control unit (When battery-power dose not work temporarily).

#### DTC Logic

INFOID:000000003826405

#### DTC DETECTION LOGIC

DTC	Display Items	Malfunction detected condition	Possible cause
C1900	CONTROL UNIT [ABNORMAL1]	Malfunction has occurred inside RAS control unit.	<ul style="list-style-type: none"><li>• RAS control unit</li><li>• Harness or connector</li></ul>
C1901	CONTROL UNIT [ABNORMAL2]	Malfunction has occurred inside RAS control unit.	<ul style="list-style-type: none"><li>• RAS control unit</li><li>• Harness or connector</li></ul>
C1906	CONTROL UNIT [ABNORMAL5]	Malfunction has occurred inside RAS control unit.	<ul style="list-style-type: none"><li>• RAS control unit</li><li>• Harness or connector</li></ul>
C1907	CONTROL UNIT [ABNORMAL4]	Malfunction has occurred inside RAS control unit.	<ul style="list-style-type: none"><li>• RAS control unit</li><li>• Harness or connector</li></ul>
C1927	CONTROL UNIT [ABNORMAL5]	Malfunction has occurred inside RAS control unit.	<ul style="list-style-type: none"><li>• RAS control unit</li><li>• Harness or connector</li></ul>

#### DTC CONFIRMATION PROCEDURE

##### 1. DTC REPRODUCTION PROCEDURE

###### With CONSULT-III

1. Turn the ignition switch from OFF to ON.
2. Perform RAS control unit self-diagnosis.

###### Without CONSULT-III

1. Start the engine.
2. Perform the self-diagnosis. Refer to [STC-35, "Diagnosis Description"](#).

Is DTC "C1900", "C1901", "C1906", "C1907", "C1927" or "RAS warning lamp flickering pattern:11" detected?

YES >> Proceed to diagnosis procedure. Refer to [STC-38, "Diagnosis Procedure"](#).

NO >> INSPECTION END

#### Diagnosis Procedure

INFOID:000000003826406

##### 1. PERFORM SELF-DIAGNOSIS

###### With CONSULT-III

1. Turn the ignition switch from OFF to ON.
2. Perform RAS control unit self-diagnosis.

###### Without CONSULT-III

1. Start the engine.
2. Perform the self-diagnosis. Refer to [STC-35, "Diagnosis Description"](#).

Is DTC "C1900", "C1901", "C1906", "C1907", "C1927" or "RAS warning lamp flickering pattern:11" detected?

YES >> Replace RAS control unit. Refer to [STC-106, "Exploded View"](#).

NO >> GO TO 2.

##### 2. CHECK INFORMATION

###### With CONSULT-III

# C1900, C1901, C1906, C1907, C1927 RAS CONTROL UNIT

[WITH REAR ACTIVE STEER]

< DTC/CIRCUIT DIAGNOSIS >

Check the "DATA MONITOR" value of each DTC detected with the self-diagnosis function. Refer to [STC-88](#), "[Reference Value](#)".

Is each data the standard value?

- YES >> Check each harness connector pin terminal for disconnection.
- NO >> Replace RAS control unit. Refer to [STC-106](#), "[Exploded View](#)".

## Special Repair Requirement

INFOID:000000004066051

### BEFORE REPLACING RAS CONTROL UNIT

- Record the self-diagnosis results (history).

#### **CAUTION:**

- **Never erase the memory (history) of self-diagnosis results when replacing RAS control unit after diagnosis.**
- **Erase the memory of the self-diagnosis results (record) after printing out or recording all the values of "DATA MONITOR".**

A  
B  
C  
D  
E  
F  
H  
I  
J  
K  
L  
M  
N  
O  
P

STC

# C1902, C1903, C1904, C1910, C1913 RAS MOTOR OUTPUT

< DTC/CIRCUIT DIAGNOSIS >

[WITH REAR ACTIVE STEER]

## C1902, C1903, C1904, C1910, C1913 RAS MOTOR OUTPUT

### Description

INFOID:000000003826408

- RAS motor activates RAS actuator.
- Maintain the toe-stiffness of rear wheels against the road external force because the irreversible sufficiency performance hypoid gear is used.

### DTC Logic

INFOID:000000003826409

### DTC DETECTION LOGIC

DTC	Display items	Malfunction detected condition	Possible cause
C1902	MOTOR OUTPUT [REV CURRENT]	RAS motor current error is detected. (RAS motor current output direction differs.)	<ul style="list-style-type: none"><li>• RAS motor</li><li>• Harness or connector</li><li>• RAS control unit</li></ul>
C1903	MOTOR OUTPUT [NO CURRENT]	RAS motor current error is detected. (Current is inputted to RAS control unit if RAS control unit output is "OFF".)	<ul style="list-style-type: none"><li>• RAS motor</li><li>• Harness or connector</li><li>• RAS control unit</li></ul>
C1904	MOTOR OUTPUT [OVERCURRENT]	RAS motor current error is detected. (RAS motor output is over current.)	<ul style="list-style-type: none"><li>• RAS motor</li><li>• Harness or connector</li><li>• RAS control unit</li></ul>
C1910	MOTOR OUTPUT [MOTOR LOCK]	RAS motor inside error is detected. (RAS motor does not move or the rear wheel angle sensor does not change if RAS control unit output is 14 A or more.)	<ul style="list-style-type: none"><li>• RAS motor</li><li>• Harness or connector</li><li>• RAS control unit</li></ul>
C1913	MOTOR OUTPUT [ABNORML SIG]	RAS motor current error is detected. (RAS motor does not move or the rear wheel angle sensor output does not change when RAS control unit output is 18 A or more, and RAS motor output is low.)	<ul style="list-style-type: none"><li>• RAS motor</li><li>• Harness or connector</li><li>• RAS control unit</li></ul>

### DTC CONFIRMATION PROCEDURE

#### 1. DTC REPRODUCTION PROCEDURE

##### Ⓟ With CONSULT-III

1. Perform "SELF DIAGNOSTIC MODE" item on "ACTIVE TEST" of RAS control unit.

##### **CAUTION:**

**Perform the active test while vehicle is stopped.**

2. Perform RAS control unit self-diagnosis.

##### ⓧ Without CONSULT-III

1. Start the engine.
2. Perform the self-diagnosis. Refer to [STC-35, "Diagnosis Description"](#).

Is DTC "C1902", "C1903", "C1904", "C1910", "C1913" or "RAS warning lamp flickering pattern:13" detected?

- YES >> Proceed to diagnosis procedure. Refer to [STC-40, "Diagnosis Procedure"](#).  
NO >> INSPECTION END

### Diagnosis Procedure

INFOID:000000003826410

#### 1. CHECK RAS MOTOR CIRCUIT

1. Turn the ignition switch OFF.
2. Disconnect RAS control unit harness connector.
3. Disconnect RAS motor harness connector.
4. Check the continuity between RAS control unit harness connector and RAS motor harness connector.



# C1902, C1903, C1904, C1910, C1913 RAS MOTOR OUTPUT

< DTC/CIRCUIT DIAGNOSIS >

[WITH REAR ACTIVE STEER]

RAS control unit		RAS motor		Continuity
Connector	Terminal	Connector	Terminal	
B37	38	B54	1	Existed
	39		2	

5. Check the continuity between RAS control unit harness connector and ground.

RAS control unit		—	Continuity
Connector	Terminal		
B37	38	Ground	Not existed
	39		

Is the inspection result normal?

YES >> GO TO 2.

NO >> Repair or replace the harnesses and connectors.

## 2. CHECK RAS MOTOR

Check RAS motor. Refer to [STC-42, "Component Inspection"](#).

Is the inspection result normal?

YES >> GO TO 3.

NO >> Replace RAS actuator assembly. Refer to [STC-107, "Exploded View"](#).

## 3. PERFORM ACTIVE TEST

### With CONSULT-III

1. Connect RAS control unit harness connector.
2. Connect RAS motor harness connector.
3. Perform "SELF DIAGNOSTIC MODE" item on "ACTIVE TEST" of RAS control unit.

**CAUTION:**

**Perform the active test while vehicle is stopped.**

4. Check "MOTOR VOLTAGE", "MOTOR CURRENT" and "MTR CRNT OPE" while performing the active test.

Monitor item	Condition	Display value
MOTOR VOLTAGE	Ignition switch: ON	Battery voltage
MOTOR CURRENT	RAS motor running	0 – 20 A
MTR CRNT OPE	RAS actuator neutral condition and vehicle straight-ahead position	Approx. -2 – 2 A
	RAS motor running	Approx. -20 – 20 A

### Without CONSULT-III

1. Disconnect RAS control unit harness connector.
2. Disconnect RAS motor harness connector.
3. Start the engine.
4. Check the voltage between RAS control unit harness connector and ground.

# C1902, C1903, C1904, C1910, C1913 RAS MOTOR OUTPUT

< DTC/CIRCUIT DIAGNOSIS >

[WITH REAR ACTIVE STEER]

RAS control unit		—	Condition	Voltage (Approx.)
Connector	Terminal			
B37	38	Ground	While RAS motor is operation for right	Battery voltage
			While RAS motor is operation for left	0V
	39		While RAS motor is operation for right	0V
			While RAS motor is operation for left	Battery voltage

Is the standard value?

YES >> GO TO 4.

NO >> Replace RAS actuator assembly. Refer to [STC-107, "Exploded View"](#).

## 4. PERFORM SELF-DIAGNOSIS

**With CONSULT-III**

1. Turn the ignition switch ON.
2. Perform RAS control unit self-diagnosis.

**Without CONSULT-III**

1. Connect RAS control unit harness connector.
2. Connect RAS motor harness connector.
3. Start the engine.
4. Perform the self-diagnosis. Refer to [STC-35, "Diagnosis Description"](#).

Is DTC "C1902", "C1903", "C1904", "C1910" or "RAS warning lamp flickering pattern:13" detected?

YES >> Replace RAS control unit. Refer to [STC-106, "Exploded View"](#).

NO >> GO TO 5.

## 5. CHECK INFORMATION

**With CONSULT-III**

Check the "DATA MONITOR" value of each DTC detected with the self-diagnosis function. Refer to [STC-88, "Reference Value"](#).

Is each data the standard value?

YES >> Check each harness connector pin terminal for disconnection.

NO >> Replace RAS control unit. Refer to [STC-106, "Exploded View"](#).

## Component Inspection

INFOID:000000003826411

### 1. CHECK RAS MOTOR

Check the continuity between RAS motor connector terminals.

RAS motor		Continuity
Connector	Terminal	
B54	1 – 2	Existed

Is the inspection result normal?

YES >> INSPECTION END

NO >> Replace RAS actuator assembly. Refer to [STC-107, "Exploded View"](#).

## Special Repair Requirement

INFOID:000000004066056

### BEFORE REPLACING RAS CONTROL UNIT

- Record the self-diagnosis results (history).

**CAUTION:**

- **Never erase the memory (history) of self-diagnosis results when replacing RAS control unit after diagnosis.**

# C1902, C1903, C1904, C1910, C1913 RAS MOTOR OUTPUT

< DTC/CIRCUIT DIAGNOSIS >

[WITH REAR ACTIVE STEER]

- Erase the memory of the self-diagnosis results (record) after printing out or recording all the values of "DATA MONITOR".

A

B

C

D

E

F

**STC**

H

I

J

K

L

M

N

O

P

# C1905, C1908, C1922, C1925, C1928 RAS CONTROL UNIT

< DTC/CIRCUIT DIAGNOSIS >

[WITH REAR ACTIVE STEER]

## C1905, C1908, C1922, C1925, C1928 RAS CONTROL UNIT

### Description

INFOID:000000003844012

- RAS actuator and the power steering solenoid valve is controlled by each sensor signal.
- The fail-safe function stops the rear wheel angle function, when the electric components and the mechanical components are malfunctioning.
- The protective function stops RAS system temporarily when the input signal is not inputted to RAS control unit (When battery-power dose not work temporarily).

### DTC Logic

INFOID:000000003826414

### DTC DETECTION LOGIC

DTC	Display items	Malfunction detected condition	Possible cause
C1905	CONTROL UNIT [ABNORMAL3]	Malfunction has occurred inside RAS control unit.	<ul style="list-style-type: none"><li>• RAS control unit</li><li>• Harness or connector</li></ul>
C1908	CONTROL UNIT [ABNORMAL7]	Malfunction has occurred inside RAS control unit.	<ul style="list-style-type: none"><li>• RAS control unit</li><li>• Harness or connector</li></ul>
C1922	CONTROL UNIT [ABNORMAL8]	Malfunction has occurred inside RAS control unit.	<ul style="list-style-type: none"><li>• RAS control unit</li><li>• Harness or connector</li></ul>
C1925	AD CONVERTER	Malfunction has occurred inside RAS control unit.	<ul style="list-style-type: none"><li>• RAS control unit</li><li>• Harness or connector</li></ul>
C1928	CONTROL UNIT [ABNORMAL9]	Malfunction has occurred inside RAS control unit.	<ul style="list-style-type: none"><li>• RAS control unit</li><li>• Harness or connector</li></ul>

### DTC CONFIRMATION PROCEDURE

#### 1. DTC REPRODUCTION PROCEDURE

##### With CONSULT-III

1. Turn the ignition switch from OFF to ON.
2. Perform RAS control unit self-diagnosis.

##### Without CONSULT-III

1. Start the engine.
2. Perform the self-diagnosis. Refer to [STC-35, "Diagnosis Description"](#).

Is DTC "C1905", "C1908", "C1922", "C1925", "C1928" or "RAS warning lamp flickering pattern:11" detected?

- YES >> Proceed to diagnosis procedure. Refer to [STC-44, "Diagnosis Procedure"](#).  
NO >> INSPECTION END

### Diagnosis Procedure

INFOID:000000003826415

#### 1. PERFORM SELF-DIAGNOSIS

##### With CONSULT-III

1. Turn the ignition switch from OFF to ON.
2. Perform RAS control unit self-diagnosis.

##### Without CONSULT-III

1. Start the engine.
2. Perform the self-diagnosis. Refer to [STC-35, "Diagnosis Description"](#).

Is DTC "C1905", "C1908", "C1922", "C1925", "C1928" or "RAS warning lamp flickering pattern:11" detected?

- YES >> Replace RAS control unit. Refer to [STC-106, "Exploded View"](#).  
NO >> GO TO 2.

#### 2. CHECK INFORMATION

##### With CONSULT-III

Check the "DATA MONITOR" value of each DTC detected with the self-diagnosis function. Refer to [STC-88, "Reference Value"](#).

# C1905, C1908, C1922, C1925, C1928 RAS CONTROL UNIT

< DTC/CIRCUIT DIAGNOSIS >

[WITH REAR ACTIVE STEER]

Is each data the standard value?

- YES >> Check each harness connector pin terminal for disconnection.
- NO >> Replace RAS control unit. Refer to [STC-106. "Exploded View"](#).

## Special Repair Requirement

INFOID:000000004066057

### BEFORE REPLACING RAS CONTROL UNIT

- Record the self-diagnosis results (history).

**CAUTION:**

- **Never erase the memory (history) of self-diagnosis results when replacing RAS control unit after diagnosis.**
- **Erase the memory of the self-diagnosis results (record) after printing out or recording all the values of "DATA MONITOR".**

A  
B  
C  
D  
E  
F  
H  
I  
J  
K  
L  
M  
N  
O  
P

STC

## C1909 RAS CONTROL UNIT

### Description

INFOID:000000003844013

- RAS actuator and the power steering solenoid valve is controlled by each sensor signal.
- The fail-safe function stops the rear wheel angle function, when the electric components and the mechanical components are malfunctioning.
- The protective function stops RAS system temporarily when the input signal is not inputted to RAS control unit (When battery-power dose not work temporarily).

### DTC Logic

INFOID:000000003826418

### DTC DETECTION LOGIC

DTC	Display items	Malfunction detected condition	Possible cause
C1909	CONTROL UNIT [ABNORMAL6]	Malfunction has occurred inside RAS control unit.	<ul style="list-style-type: none"> <li>• RAS control unit</li> <li>• Harness or connector</li> </ul>

### DTC CONFIRMATION PROCEDURE

#### 1. DTC REPRODUCTION PROCEDURE

**☑ With CONSULT-III**

1. Turn the ignition switch from OFF to ON.
2. Perform RAS control unit self-diagnosis.

**☒ Without CONSULT-III**

1. Start the engine.
2. Perform the self-diagnosis. Refer to [STC-35, "Diagnosis Description"](#).

Is DTC "C1909" or "RAS warning lamp flickering pattern:11" detected?

- YES >> Proceed to diagnosis procedure. Refer to [STC-46, "Diagnosis Procedure"](#).  
 NO >> INSPECTION END

### Diagnosis Procedure

INFOID:000000003826419

#### 1. CHECK RAS CONTROL UNIT POWER SUPPLY

1. Turn the ignition switch OFF.
2. Disconnect RAS control unit harness connector.
3. Check the voltage between RAS control unit harness connector terminal and ground.

RAS control unit		—	Voltage (Approx.)
Connector	Terminal		
B37	27	Ground	0 V

4. Turn the ignition switch ON.  
**CAUTION:**  
**Never start the engine.**
5. Check the voltage between RAS control unit harness connector terminal and ground.

RAS control unit		—	Voltage (Approx.)
Connector	Terminal		
B37	27	Ground	Battery voltage

Is the inspection result normal?

- YES >> GO TO 2.  
 NG >> Check the following items. Repair or replace the malfunctioning parts.
- 10A fuse (#45) open
  - Short among 10A fuse (#45) connector, RAS control unit harness connector No. 27 terminal and the ground

# C1909 RAS CONTROL UNIT

[WITH REAR ACTIVE STEER]

## < DTC/CIRCUIT DIAGNOSIS >

- Open between the ignition switch and RAS control unit harness connector No. 27 terminal
- Ignition switch

### 2. CHECK RAS CONTROL UNIT GROUND

Check the continuity between RAS control unit harness connector and ground.

RAS control unit		—	Continuity
Connector	Terminal		
B37	34	Ground	Existed

Is the inspection result normal?

YES >> GO TO 3.

NG >> Repair or replace the harnesses and connectors.

### 3. PERFORM SELF-DIAGNOSIS

#### With CONSULT-III

1. Connect RAS control unit harness connector.
2. Turn the ignition switch from OFF to ON.
3. Perform RAS control unit self-diagnosis.

#### Without CONSULT-III

1. Connect RAS control unit harness connector.
2. Start the engine.
3. Perform the self-diagnosis. Refer to [STC-35. "Diagnosis Description"](#).

Is DTC "C1909" or "RAS warning lamp flickering pattern:11" detected?

YES >> Replace RAS control unit. Refer to [STC-106. "Exploded View"](#).

NO >> GO TO 4.

### 4. CHECK INFORMATION

#### With CONSULT-III

Check the "DATA MONITOR" value of each DTC detected with the self-diagnosis function. Refer to [STC-88. "Reference Value"](#).

Is each data the standard value?

YES >> Check each harness connector pin terminal for disconnection.

NO >> Replace RAS control unit. Refer to [STC-106. "Exploded View"](#).

### Special Repair Requirement

INFOID:000000004066062

#### BEFORE REPLACING RAS CONTROL UNIT

- Record the self-diagnosis results (history).

#### **CAUTION:**

- **Never erase the memory (history) of self-diagnosis results when replacing RAS control unit after diagnosis.**
- **Erase the memory of the self-diagnosis results (record) after printing out or recording all the values of "DATA MONITOR".**

# C1911, C1912 RAS MOTOR POWER SUPPLY

< DTC/CIRCUIT DIAGNOSIS >

[WITH REAR ACTIVE STEER]

## C1911, C1912 RAS MOTOR POWER SUPPLY

### Description

INFOID:000000003826421

The power supply for RAS motor.

### DTC Logic

INFOID:000000003826422

### DTC DETECTION LOGIC

DTC	Display items	Malfunction detected condition	Possible cause
C1911	MOTOR VOLTAGE [LOW VOLTAGE]	RAS motor voltage error is detected. (RAS motor voltage is low.)	<ul style="list-style-type: none"><li>• RAS motor relay</li><li>• Harness or connector</li><li>• RAS control unit</li></ul>
C1912	MOTOR VOLTAGE [BAD OBSTRCT]	RAS motor voltage error is detected. (Voltage is applied to RAS motor when RAS control unit output is "OFF".)	<ul style="list-style-type: none"><li>• RAS motor relay</li><li>• Harness or connector</li><li>• RAS control unit</li></ul>

### DTC CONFIRMATION PROCEDURE

#### 1. DTC REPRODUCTION PROCEDURE

##### With CONSULT-III

1. Turn the ignition switch from OFF to ON.
2. Perform RAS control unit self-diagnosis.

##### Without CONSULT-III

1. Start the engine.
2. Perform the self-diagnosis. Refer to [STC-35, "Diagnosis Description"](#).

Is DTC "C1911", "C1912" or "RAS warning lamp flickering pattern:12" detected?

- YES >> Proceed to diagnosis procedure. Refer to [STC-48, "Diagnosis Procedure"](#).  
NO >> INSPECTION END

### Diagnosis Procedure

INFOID:000000003826423

#### 1. CHECK RAS CONTROL UNIT POWER SUPPLY

1. Turn the ignition switch OFF.
2. Disconnect RAS control unit harness connector.
3. Check the voltage between RAS control unit harness connector and ground.

RAS control unit		—	Voltage (Approx.)
Connector	Terminal		
B37	27	Ground	0 V

4. Turn the ignition switch ON.

##### **CAUTION:**

**Never start the engine.**

5. Check the voltage between RAS control unit harness connector and ground.

RAS control unit		—	Voltage (Approx.)
Connector	Terminal		
B37	27	Ground	Battery voltage

Is the inspection result normal?

- YES >> GO TO 2.  
NG >> Check the following items. Repair or replace the malfunctioning parts.
- 10A fuse (#45) open
  - Short among 10A fuse (#45) connector, RAS control unit harness connector No. 27 terminal and the ground



# C1911, C1912 RAS MOTOR POWER SUPPLY

[WITH REAR ACTIVE STEER]

## < DTC/CIRCUIT DIAGNOSIS >

- Open between the ignition switch and RAS control unit harness connector No. 27 terminal
- Ignition switch

### 2.CHECK RAS MOTOR POWER SUPPLY CIRCUIT (1)

1. Turn the ignition switch OFF.
2. Remove RAS motor relay.
3. Check the continuity between RAS motor relay harness connector and ground.

RAS motor relay		—	Continuity
Connector	Terminal		
B36	1	Ground	Existed
	2		Not existed

4. Check the continuity between RAS motor relay harness connector and RAS control unit harness connector.

RAS motor relay		RAS control unit		Continuity
Connector	Terminal	Connector	Terminal	
B36	2	B37	25	Existed

Is the inspection result normal?

YES >> GO TO 3.

NO >> Repair or replace the harnesses and connectors.

### 3.CHECK RAS MOTOR POWER SUPPLY CIRCUIT (2)

Check the voltage between RAS motor relay harness connector and ground.

RAS motor relay		—	Voltage (Approx.)
Connector	Terminal		
B36	3	Ground	Battery voltage

Is the inspection result normal?

YES >> GO TO 4.

NO >> Check the following items. Repair or replace the malfunctioning parts.

- 20A fuse (#37) open
- Short among 20A fuse (#37) connector, RAS motor relay harness connector No. 3 terminal and the ground
- Open between the battery and RAS motor relay harness connector No. 3 terminal

### 4.CHECK RAS MOTOR POWER SUPPLY CIRCUIT (3)

1. Remove the noise suppressor.
2. Check continuity between the noise suppressor harness connector and ground.

Noise suppressor		—	Continuity
Connector	Terminal		
B39	3	Ground	Not existed
	5		Not existed
B40	1		Not existed
	2		Existed

3. Check the continuity between the noise suppressor harness connector and RAS motor relay harness connector.

Noise suppressor		RAS motor relay		Continuity
Connector	Terminal	Connector	Terminal	
B40	1	B36	5	Existed

A  
B  
C  
D  
E  
F  
H  
I  
J  
K  
L  
M  
N  
O  
P

STC

# C1911, C1912 RAS MOTOR POWER SUPPLY

[WITH REAR ACTIVE STEER]

## < DTC/CIRCUIT DIAGNOSIS >

4. Check the continuity between the noise suppressor harness connector and RAS control unit harness connector.

Noise suppressor		RAS control unit		Continuity
Connector	Terminal	Connector	Terminal	
B39	3	B37	37	Existed
	5		40	Existed

Is the inspection result normal?

YES >> GO TO 5.

NO >> Repair or replace the harnesses and connectors.

## 5. CHECK RAS MOTOR POWER SUPPLY CIRCUIT (4)

1. Connect RAS control unit harness connector.
2. Turn the ignition switch ON.

### CAUTION:

**Never start the engine.**

3. Check the voltage between RAS control unit harness connector and ground.

RAS control unit		—	Voltage (Approx.)
Connector	Terminal		
B37	25	Ground	Battery voltage

4. Turn the ignition switch OFF.

Is the inspection result normal?

YES >> GO TO 6.

NO >> Replace RAS control unit. Refer to [STC-106, "Exploded View"](#).

## 6. CHECK RAS MOTOR RELAY

1. Check the RAS motor relay. Refer to [STC-51, "Component Inspection \(RAS Motor Relay\)"](#).

Is the inspection result normal?

YES >> GO TO 7.

NO >> Replace RAS motor relay.

## 7. CHECK NOISE SUPPRESSOR

Check the noise suppressor. Refer to [STC-51, "Component Inspection \(Noise Suppressor\)"](#).

Is the inspection result normal?

YES >> GO TO 8.

NO >> Replace the noise suppressor.

## 8. CHECK RAS MOTOR POWER SUPPLY

1. Install RAS rear motor relay.
2. Install the noise suppressor.
3. Turn the ignition switch ON.

### CAUTION:

**Never start the engine.**

4. Check the voltage between RAS control unit harness connector and ground.

RAS control unit		—	Voltage (Approx.)
Connector	Terminal		
B37	37	Ground	Battery voltage

Is the inspection result normal?

YES >> GO TO 9.

NO >> Replace RAS control unit. Refer to [STC-106, "Exploded View"](#).

## 9. PERFORM SELF-DIAGNOSIS (RAS CONTROL UNIT)

# C1911, C1912 RAS MOTOR POWER SUPPLY

< DTC/CIRCUIT DIAGNOSIS >

[WITH REAR ACTIVE STEER]

## With CONSULT-III

1. Turn the ignition switch from OFF to ON.
2. Perform RAS control unit self-diagnosis.

## Without CONSULT-III

1. Start the engine.
2. Perform the self-diagnosis. Refer to [STC-35. "Diagnosis Description"](#).

Is DTC "C1911", "C1912" or "RAS warning lamp flickering pattern:12" detected?

- YES >> Replace RAS control unit. Refer to [STC-106. "Exploded View"](#).  
NO >> GO TO 10.

## 10.CHECK INFORMATION

## With CONSULT-III

Check the "DATA MONITOR" value of each DTC detected with the self-diagnosis function. Refer to [STC-88. "Reference Value"](#).

Is each data the standard value?

- YES >> Check each harness connector pin terminal for disconnection.  
NO >> Replace RAS control unit. Refer to [STC-106. "Exploded View"](#).

## Component Inspection (RAS Motor Relay)

INFOID:0000000003826424

### 1.CHECK RAS MOTOR RELAY

1. Apply 12 V to RAS motor relay connector No. 1 terminal and No. 2 terminal.

#### **CAUTION:**

- **Never make the terminals short.**
- **Connect the fuse between the terminals when applying the voltage.**

2. Check the continuity between RAS motor relay connector.

RAS motor relay			Continuity	
Connector	Terminal			Condition
B36	3	5	Apply the voltage between No. 1 terminal and No. 2 terminal.	Existed
			Do not apply the voltage between No. 1 terminal and No. 2 terminal.	Not existed

3. Check the resistance between RAS motor relay connector.

RAS motor relay			Resistance (Approx.)
Connector	Terminal		
B36	1	2	50 Ω

Is the inspection result normal?

- YES >> INSPECTION END  
NO >> Replace RAS motor relay.

## Component Inspection (Noise Suppressor)

INFOID:0000000003826425

### 1.CHECK NOISE SUPPRESSOR

Check continuity between the noise suppressor connector.

# C1911, C1912 RAS MOTOR POWER SUPPLY

< DTC/CIRCUIT DIAGNOSIS >

[WITH REAR ACTIVE STEER]

Noise suppressor				Continuity
Connector	Terminal	Connector	Terminal	
B39	3	B40	1	Existed
	3	B39	5	Not existed
	3	B40	2	Not existed
	5	B40	2	Existed
	5	B40	1	Not existed

Is the inspection result normal?

YES >> INSPECTION END

NO >> Replace the noise suppressor.

## Special Repair Requirement

INFOID:000000004066063

### BEFORE REPLACING RAS CONTROL UNIT

- Record the self-diagnosis results (history).

**CAUTION:**

- Never erase the memory (history) of self-diagnosis results when replacing RAS control unit after diagnosis.
- Erase the memory of the self-diagnosis results (record) after printing out or recording all the values of "DATA MONITOR".

# C1914 REAR WHEEL STEERING ANGLE SENSOR

< DTC/CIRCUIT DIAGNOSIS >

[WITH REAR ACTIVE STEER]

## C1914 REAR WHEEL STEERING ANGLE SENSOR

### Description

INFOID:000000003826427

- It detects the steering angle condition of rear wheel.
- 2 systems (main and sub sensor) are equipped.

### DTC Logic

INFOID:000000003826428

### DTC DETECTION LOGIC

DTC	Display items	Malfunction detected condition	Possible cause
C1914	RR ST ANGLE SENSOR [ABNORML VOL]	The rear wheel angle sensor (main) or (sub) power supply value is malfunction.	<ul style="list-style-type: none"><li>• RAS actuator assembly (Rear wheel angle sensor)</li><li>• Harness or connector</li><li>• RAS control unit</li></ul>

### DTC CONFIRMATION PROCEDURE

#### 1. DTC REPRODUCTION PROCEDURE

##### With CONSULT-III

1. Turn the ignition switch from OFF to ON.
2. Perform RAS control unit self-diagnosis.

##### Without CONSULT-III

1. Start the engine.
2. Perform the self-diagnosis. Refer to [STC-35, "Diagnosis Description"](#).

Is DTC "C1914" or "RAS warning lamp flickering pattern:24" detected?

- YES >> Proceed to diagnosis procedure. Refer to [STC-53, "Diagnosis Procedure"](#).  
NO >> INSPECTION END

### Diagnosis Procedure

INFOID:000000003826429

#### 1. CHECK REAR WHEEL STEERING ANGLE SENSOR POWER SUPPLY

1. Turn the ignition switch OFF.
2. Check the voltage between RAS control unit harness connector and ground.

RAS control unit		—	Voltage (Approx.)
Connector	Terminal		
B37	5	Ground	0 V

3. Turn the ignition switch ON.  
**CAUTION:**  
**Never start the engine.**
4. Check the voltage between RAS control unit harness connector and ground.

RAS control unit		—	Value (Approx.)
Connector	Terminal		
B37	5	Ground	5 V

Is the inspection result normal?

- YES >> GO TO 2.  
NO >> Replace RAS control unit. Refer to [STC-106, "Exploded View"](#).

#### 2. CHECK REAR WHEEL STEERING ANGLE SENSOR

Check the rear wheel steering angle sensor. Refer to [STC-54, "Component Inspection"](#).

Is the inspection result normal?

A  
B  
C  
D  
E  
F  
H  
I  
J  
K  
L  
M  
N  
O  
P

STC

# C1914 REAR WHEEL STEERING ANGLE SENSOR

[WITH REAR ACTIVE STEER]

## < DTC/CIRCUIT DIAGNOSIS >

YES >> GO TO 3.

NO >> Replace RAS actuator assembly. Refer to [STC-107, "Exploded View"](#).

### 3. CHECK REAR WHEEL STEERING ANGLE SENSOR POWER SUPPLY CIRCUIT

1. Disconnect RAS control unit harness connector.
2. Check the continuity between RAS control unit harness connector and rear wheel steering angle sensor harness connector.

RAS control unit		Rear wheel steering angle sensor		Continuity
Connector	Terminal	Connector	Terminal	
B37	5	B53	1	Existed
	5		4	Not existed
	15		4	Existed
	15		1	Not existed

Is the inspection result normal?

YES >> GO TO 4.

NO >> Repair or replace the harnesses and connectors.

### 4. PERFORM SELF-DIAGNOSIS

1. Connect RAS control unit harness connector.
2. Connect the rear wheel steering angle sensor harness connector.

#### With CONSULT-III

1. Turn the ignition switch from OFF to ON.
2. Perform RAS control unit self-diagnosis.

#### Without CONSULT-III

1. Start the engine.
2. Perform the self-diagnosis. Refer to [STC-35, "Diagnosis Description"](#).

Is DTC "C1914" or "RAS warning lamp flickering pattern:24" detected?

YES >> Replace RAS control unit. Refer to [STC-106, "Exploded View"](#).

NO >> GO TO 5.

### 5. CHECK INFORMATION

#### With CONSULT-III

Check the "DATA MONITOR" value of each DTC detected with the self-diagnosis function. Refer to [STC-88, "Reference Value"](#).

Is each data the standard value?

YES >> Check each harness connector pin terminal for disconnection.

NO >> Replace RAS control unit. Refer to [STC-106, "Exploded View"](#).

## Component Inspection

INFOID:000000003826430

### 1. CHECK REAR WHEEL STEERING ANGLE SENSOR

1. Turn the ignition switch OFF.
2. Disconnect the rear wheel steering angle sensor harness connector.
3. Check the resistance between the rear wheel steering angle sensor connector.

Rear wheel steering angle sensor			Resistance (Approx.)
Connector	Terminal		
B53	1	4	1 kΩ
	1	2	1.2 – 1.5 kΩ
	1	3	1.2 – 1.5 kΩ

Is the inspection result normal?

YES >> INSPECTION END

NO >> Replace RAS actuator assembly. Refer to [STC-107, "Exploded View"](#).

# C1914 REAR WHEEL STEERING ANGLE SENSOR

< DTC/CIRCUIT DIAGNOSIS >

[WITH REAR ACTIVE STEER]

## Special Repair Requirement

INFOID:000000004066064

### BEFORE REPLACING RAS CONTROL UNIT

- Record the self-diagnosis results (history).

**CAUTION:**

- Never erase the memory (history) of self-diagnosis results when replacing RAS control unit after diagnosis.
- Erase the memory of the self-diagnosis results (record) after printing out or recording all the values of "DATA MONITOR".

A  
B  
C  
D  
E  
F  
H  
I  
J  
K  
L  
M  
N  
O  
P

STC

# C1915, C1916 REAR WHEEL STEERING ANGLE SENSOR

< DTC/CIRCUIT DIAGNOSIS >

[WITH REAR ACTIVE STEER]

## C1915, C1916 REAR WHEEL STEERING ANGLE SENSOR

### Description

INFOID:000000003826432

- It detects the steering angle condition of rear wheel.
- 2 systems (main and sub sensor) are equipped.

### DTC Logic

INFOID:000000003826433

### DTC DETECTION LOGIC

DTC	Display items	Malfunction detected condition	Possible cause
C1915	RR ST ANGLE SENSOR [MAIN SIGNAL]	The rear wheel angle sensor signal (main) output signal is malfunction.	<ul style="list-style-type: none"><li>• RAS actuator assembly (Rear wheel angle sensor)</li><li>• Harness or connector</li><li>• RAS control unit</li></ul>
C1916	RR ST ANGLE SENSOR [SUB SIGNAL]	The rear wheel angle sensor signal (sub) output signal is malfunction.	<ul style="list-style-type: none"><li>• RAS actuator assembly (Rear wheel angle sensor)</li><li>• Harness or connector</li><li>• RAS control unit</li></ul>

### DTC CONFIRMATION PROCEDURE

#### 1. DTC REPRODUCTION PROCEDURE

##### With CONSULT-III

1. Turn the ignition switch from OFF to ON.
2. Perform RAS control unit self-diagnosis.

##### Without CONSULT-III

1. Start the engine.
2. Perform the self-diagnosis. Refer to [STC-35, "Diagnosis Description"](#).

Is DTC "C1915", "C1916" or "RAS warning lamp flickering pattern:24" detected?

- YES >> Proceed to diagnosis procedure. Refer to [STC-56, "Diagnosis Procedure"](#).  
NO >> INSPECTION END

### Diagnosis Procedure

INFOID:000000003826434

#### 1. CHECK RAS REAR ACTUATOR

1. Turn the ignition switch OFF.
2. Measure (A) and (B) of RAS actuator assembly as shown in the figure.

Is the differential of (A) and (B) 5.8 mm (0.228 in) or less?

- YES >> GO TO 2.  
NO >> Replace RAS actuator assembly. Refer to [STC-107, "Exploded View"](#).

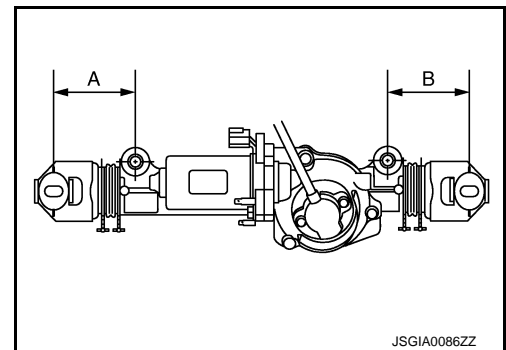

#### 2. CHECK REAR WHEEL STEERING ANGLE SENSOR (1)

##### With CONSULT-III

1. Start the engine.  
**CAUTION:**  
**Check condition with the vehicle stopped.**
2. Check DATA MONITOR "RR ST ANG-MAI" and "RR ST ANG-SUB" value of RAS control unit.



# C1915, C1916 REAR WHEEL STEERING ANGLE SENSOR

< DTC/CIRCUIT DIAGNOSIS >

[WITH REAR ACTIVE STEER]

Monitored item	Condition	Display value
RR ST ANG-MAI	Straight-ahead	Approx. 2.4 V
RR ST ANG-SUB	Straight-ahead	Approx. 2.6 V

Is the inspection result normal?

YES >> GO TO 3.

NO >> Replace RAS actuator assembly. Refer to [STC-107. "Exploded View"](#).

## 3.CHECK REAR WHEEL STEERING ANGLE SENSOR (2)

Check the voltage between RAS control unit harness connector and ground.

RAS control unit		—	Voltage (Approx.)
Connector	Terminal		
B37	4	Ground	2.4 V
	7		2.6 V

Is the differential between terminal voltage No. 4 and No.7 approximately 1 V or more?

YES >> Replace RAS control unit. Refer to [STC-106. "Exploded View"](#).

NO >> GO TO 4.

## 4.CHECK REAR WHEEL STEERING ANGLE SENSOR (3)

1. Check the rear wheel steering angle sensor. Refer to [STC-58. "Component Inspection"](#).

Is the inspection result normal?

YES >> GO TO 5.

NO >> Replace RAS actuator assembly. Refer to [STC-107. "Exploded View"](#).

## 5.CHECK REAR WHEEL STEERING ANGLE SENSOR GROUND CIRCUIT

1. Disconnect RAS control unit harness connector.

2. Check for continuity between RAS control unit harness connector and rear wheel steering angle sensor harness connector.

RAS control unit		Rear wheel steering angle sensor		Continuity
Connector	Terminal	Connector	Terminal	
B37	4	B53	1, 2, 4	Not existed
	4		3	Existed
	7		1, 3, 4	Not existed
	7		2	Existed
	5		2, 3, 4	Not existed
	5		1	Existed
	15		1, 2, 3	Not existed
	15		4	Existed

Is the inspection result normal?

YES >> GO TO 6.

NO >> Repair or replace each harness and connector.

## 6.PERFORM SELF-DIAGNOSIS

1. Connect RAS control unit harness connector.

2. Connect the rear wheel steering angle sensor harness connector.

 **With CONSULT-III**

1. Turn the ignition switch from OFF to ON.

2. Perform RAS control unit self-diagnosis.

 **Without CONSULT-III**

1. Start the engine.

# C1915, C1916 REAR WHEEL STEERING ANGLE SENSOR

< DTC/CIRCUIT DIAGNOSIS >

[WITH REAR ACTIVE STEER]

2. Perform the self-diagnosis. Refer to [STC-35. "Diagnosis Description"](#).

Is DTC "C1915", "C1916" or "RAS warning lamp flickering pattern:24" detected?

YES >> Replace RAS control unit. Refer to [STC-106. "Exploded View"](#).

NO >> GO TO 7.

## 7. CHECK INFORMATION

 **With CONSULT-III**

Check the "DATA MONITOR" value of each DTC detected with the self-diagnosis function. Refer to [STC-88. "Reference Value"](#).

Is each data standard?

YES >> Check pin terminal and connection of each harness connector for non-standard conditions.

NO >> Replace RAS control unit. Refer to [STC-106. "Exploded View"](#).

## Component Inspection

INFOID:000000003826435

### 1. CHECK REAR WHEEL STEERING ANGLE SENSOR

1. Turn the ignition switch OFF.
2. Disconnect rear wheel steering angle sensor harness connector.
3. Check the resistance between rear wheel steering angle sensor connector.

Rear wheel steering angle sensor			Resistance (Approx.)
Connector	Terminal		
B53	1	4	1 kΩ
	1	2	1.2 – 1.5 kΩ
	1	3	1.2 – 1.5 kΩ

Is the inspection result normal?

YES >> INSPECTION END

NO >> Replace RAS actuator assembly. Refer to [STC-107. "Exploded View"](#).

## Special Repair Requirement

INFOID:000000004066065

### BEFORE REPLACING RAS CONTROL UNIT

- Record the self-diagnosis results (history).

#### **CAUTION:**

- **Never erase the memory (history) of self-diagnosis results when replacing RAS control unit after diagnosis.**
- **Erase the memory of the self-diagnosis results (record) after printing out or recording all the values of "DATA MONITOR".**

# C1917, C1918 REAR WHEEL STEERING ANGLE SENSOR

< DTC/CIRCUIT DIAGNOSIS >

[WITH REAR ACTIVE STEER]

## C1917, C1918 REAR WHEEL STEERING ANGLE SENSOR

### Description

INFOID:000000003826437

- It detects the steering angle condition of rear wheel.
- 2 systems (main and sub sensor) are equipped.

### DTC Logic

INFOID:000000003826438

### DTC DETECTION LOGIC

DTC	Display items	Malfunction detected condition	Possible cause
C1917	RR ST ANGLE SENSOR [OFFSET SIG1]	The output signal value differs temporarily between rear wheel steering angle sensor (main) and (sub).	<ul style="list-style-type: none"><li>• RAS actuator assembly (Rear wheel angle sensor)</li><li>• Harness or connector</li><li>• RAS control unit</li></ul>
C1918	RR ST ANGLE SENSOR [OFFSET SIG2]	The output signal value differs between rear wheel steering angle sensor (main) and (sub).	<ul style="list-style-type: none"><li>• RAS actuator assembly (Rear wheel angle sensor)</li><li>• Harness or connector</li><li>• RAS control unit</li></ul>

A

B

C

D

E

F

STC

### DTC CONFIRMATION PROCEDURE

#### 1. DTC REPRODUCTION PROCEDURE

##### With CONSULT-III

1. Turn the ignition switch from OFF to ON.
2. Perform RAS control unit self-diagnosis.

##### Without CONSULT-III

1. Start the engine.
2. Perform the self-diagnosis. Refer to [STC-35, "Diagnosis Description"](#).

Is DTC "C1917", "C1918" or "RAS warning lamp flickering pattern:24" detected?

- YES >> Proceed to diagnosis procedure. Refer to [STC-59, "Diagnosis Procedure"](#).  
NO >> INSPECTION END

### Diagnosis Procedure

INFOID:000000003826439

#### 1. CHECK REAR WHEEL STEERING ANGLE SENSOR (1)

##### With CONSULT-III

1. Start the engine.  
**CAUTION:**  
**Check condition with the vehicle stopped.**
2. Check "RR ST ANG-MAI" and "RR ST ANG-SUB" item on "DATA MONITOR" of RAS control unit.

Monitored item	Condition	Display value
RR ST ANG-MAI	Straight-ahead	Approx. 2.4 V
RR ST ANG-SUB	Straight-ahead	Approx. 2.6 V

Is the inspection result normal?

- YES >> GO TO 2.  
NO >> Replace RAS actuator assembly. Refer to [STC-107, "Exploded View"](#).

#### 2. CHECK REAR WHEEL STEERING ANGLE SENSOR (2)

Check the voltage between RAS control unit harness connector and ground.

H

I

J

K

L

M

N

O

P

# C1917, C1918 REAR WHEEL STEERING ANGLE SENSOR

< DTC/CIRCUIT DIAGNOSIS >

[WITH REAR ACTIVE STEER]

RAS control unit		—	Voltage (Approx.)
Connector	Terminal		
B37	4	Ground	2.4 V
	7		2.6 V

Is the differential between terminal voltage No. 4 and No.7 approximately 1 V or more?

- YES >> Replace RAS control unit. Refer to [STC-106, "Exploded View"](#).  
NO >> GO TO 3.

## 3. CHECK REAR WHEEL STEERING ANGLE SENSOR (3)

Check the rear wheel steering angle sensor. Refer to [STC-61, "Component Inspection"](#).

Is the inspection result normal?

- YES >> GO TO 4.  
NO >> Replace RAS actuator assembly. Refer to [STC-107, "Exploded View"](#).

## 4. CHECK REAR WHEEL STEERING ANGLE SENSOR GROUND CIRCUIT

1. Disconnect RAS control unit harness connector.
2. Check for continuity between RAS control unit harness connector terminal and rear wheel steering angle sensor harness connector.

RAS control unit		Rear wheel steering angle sensor		Continuity
Connector	Terminal	Connector	Terminal	
B37	4	B53	1, 2, 4	Not existed
	4		3	Existed
	7		1, 3, 4	Not existed
	7		2	Existed
	5		2, 3, 4	Not existed
	5		1	Existed
	15		1, 2, 3	Not existed
	15		4	Existed

Is the inspection result normal?

- YES >> GO TO 5.  
NO >> Repair or replace each harness and connector.

## 5. PERFORM SELF-DIAGNOSIS

### With CONSULT-III

1. Turn the ignition switch from OFF to ON.
2. Perform RAS control unit self-diagnosis.

### Without CONSULT-III

1. Start the engine.
2. Perform the self-diagnosis. Refer to [STC-35, "Diagnosis Description"](#).

Is DTC "C1917", "C1918" or "RAS warning lamp flickering pattern:24" detected?

- YES >> Replace RAS control unit. Refer to [STC-106, "Exploded View"](#).  
NO >> GO TO 6.

## 6. CHECK INFORMATION

### With CONSULT-III

Check the "DATA MONITOR" value of each DTC detected with the self-diagnosis function. Refer to [STC-88, "Reference Value"](#).

Is each data standard?

- YES >> Check pin terminal and connection of each harness connector for non-standard conditions.  
NO >> Replace RAS control unit. Refer to [STC-106, "Exploded View"](#).

# C1917, C1918 REAR WHEEL STEERING ANGLE SENSOR

< DTC/CIRCUIT DIAGNOSIS >

[WITH REAR ACTIVE STEER]

## Component Inspection

INFOID:000000003826440

### 1. CHECK REAR WHEEL STEERING ANGLE SENSOR (3)

1. Turn the ignition switch OFF.
2. Disconnect rear wheel steering angle sensor harness connector.
3. Check resistance between rear wheel steering angle sensor connector.

Rear wheel steering angle sensor			Resistance (Approx.)
Connector	Terminal		
B53	1	4	1 kΩ
	1	2	1.2 – 1.5 kΩ
	1	3	1.2 – 1.5 kΩ

Is the inspection result normal?

YES >> INSPECTION END

NO >> Replace RAS actuator assembly. Refer to [STC-107, "Exploded View"](#).

## Special Repair Requirement

INFOID:000000004066066

### BEFORE REPLACING RAS CONTROL UNIT

- Record the self-diagnosis results (history).

**CAUTION:**

- **Never erase the memory (history) of self-diagnosis results when replacing RAS control unit after diagnosis.**
- **Erase the memory of the self-diagnosis results (record) after printing out or recording all the values of "DATA MONITOR".**

A  
B  
C  
D  
E  
F  
H  
I  
J  
K  
L  
M  
N  
O  
P

STC

# C1919 VEHICLE SPEED SIGNAL

< DTC/CIRCUIT DIAGNOSIS >

[WITH REAR ACTIVE STEER]

## C1919 VEHICLE SPEED SIGNAL

### Description

INFOID:000000003826442

The vehicle speed signal is transmitted from ABS actuator and electric unit (control unit) to RAS control unit via CAN communication.

### DTC Logic

INFOID:000000003826443

### DTC DETECTION LOGIC

DTC	Display items	Malfunction detected condition	Possible cause
C1919	VEHICLE SPEED SEN [NO SIGNAL]	Malfunction is detected in vehicle speed signal that is output from ABS actuator and electric unit (control unit) via CAN communication. (Improper signal inputs while driving.)	<ul style="list-style-type: none"><li>• ABS actuator and electric unit (control unit)</li><li>• CAN communication line</li><li>• RAS control unit</li></ul>

### DTC CONFIRMATION PROCEDURE

#### 1. DTC REPRODUCTION PROCEDURE

##### With CONSULT-III

1. Turn the ignition switch from OFF to ON.
2. Perform RAS control unit self-diagnosis.

##### Without CONSULT-III

1. Start the engine.
2. Perform the self-diagnosis. Refer to [STC-35. "Diagnosis Description"](#).

Is DTC "C1919" or "RAS warning lamp flickering pattern:21" detected?

- YES >> Proceed to diagnosis procedure. Refer to [STC-62. "Diagnosis Procedure"](#).  
NO >> INSPECTION END

### Diagnosis Procedure

INFOID:000000003826444

#### 1. PERFORM ABS ACTUATOR AND ELECTRIC UNIT (CONTROL UNIT) SELF-DIAGNOSIS

##### With CONSULT-III

Perform ABS actuator and electrical unit (control unit) self-diagnosis.

Is any error system detected?

- YES >> Check the error system.  
NO >> GO TO 2.

#### 2. PERFORM SELF-DIAGNOSIS

##### With CONSULT-III

Perform RAS control unit self-diagnosis.

Is DTC "U1000" or "U1010" detected?

- YES >> Check the error system.  
NO >> GO TO 3.

#### 3. PERFORM SELF-DIAGNOSIS

##### With CONSULT-III

1. Turn the ignition switch from OFF to ON.
2. Perform RAS control unit self-diagnosis.

##### Without CONSULT-III

1. Start the engine.
2. Perform the self-diagnosis. Refer to [STC-35. "Diagnosis Description"](#).

Is DTC "C1919" or "RAS warning lamp flickering pattern:21" detected?

- YES >> Replace RAS control unit. Refer to [STC-106. "Exploded View"](#).  
NO >> GO TO 4.

# C1919 VEHICLE SPEED SIGNAL

< DTC/CIRCUIT DIAGNOSIS >

[WITH REAR ACTIVE STEER]

## 4. INFORMATION CHECK

### With CONSULT-III

Check the "DATA MONITOR" value of each DTC detected with the self-diagnosis function. Refer to [STC-88](#), "Reference Value".

Is each data the standard value?

- YES >> Check that there is no malfunction in each harness connector pin terminal or disconnection.
- NO >> Replace RAS control unit. Refer to [STC-106](#), "Exploded View".

## Special Repair Requirement

INFOID:000000004066067

### BEFORE REPLACING RAS CONTROL UNIT

- Record the self-diagnosis results (history).

#### **CAUTION:**

- **Never erase the memory (history) of self-diagnosis results when replacing RAS control unit after diagnosis.**
- **Erase the memory of the self-diagnosis results (record) after printing out or recording all the values of "DATA MONITOR".**

A  
B  
C  
D  
E  
F  
H  
I  
J  
K  
L  
M  
N  
O  
P

STC

# C1920 STEERING ANGLE SENSOR

< DTC/CIRCUIT DIAGNOSIS >

[WITH REAR ACTIVE STEER]

## C1920 STEERING ANGLE SENSOR

### Description

INFOID:000000003826446

Steering angle sensor signal is transmitted from steering angle sensor to RAS control unit via CAN communication.

### DTC Logic

INFOID:000000003826447

### DTC DETECTION LOGIC

DTC	Display items	Malfunction detected condition	Possible cause
C1920	STEERING ANGLE SEN [NO SIGNAL]	Malfunction is detected in steering angle sensor signal that is output from steering angle sensor via CAN communication. (No transmission from the steering angle sensor)	<ul style="list-style-type: none"><li>Steering angle sensor</li><li>CAN communication line</li><li>RAS control unit</li></ul>

### DTC CONFIRMATION PROCEDURE

#### 1. DTC REPRODUCTION PROCEDURE

##### With CONSULT-III

- Turn the ignition switch from OFF to ON.
- Perform RAS control unit self-diagnosis.

##### Without CONSULT-III

- Start the engine.
- Perform the self-diagnosis. Refer to [STC-35, "Diagnosis Description"](#).

Is DTC "C1920" or "RAS warning lamp flickering pattern:22" detected?

- YES >> Proceed to diagnosis procedure. Refer to [STC-64, "Diagnosis Procedure"](#).  
NO >> INSPECTION END

### Diagnosis Procedure

INFOID:000000003826448

#### 1. PERFORM ABS ACTUATOR AND ELECTRIC UNIT (CONTROL UNIT) SELF-DIAGNOSIS

##### With CONSULT-III

Perform ABS actuator and electric unit (control unit) self-diagnosis.

Is any error system detected?

- YES >> Check the error system.  
NO >> GO TO 2.

#### 2. PERFORM SELF-DIAGNOSIS

##### With CONSULT-III

Perform RAS control unit self-diagnosis.

Is DTC "U1000" or "U1010" detected?

- YES >> Check the error system.  
NO >> GO TO 3.

#### 3. PERFORM SELF-DIAGNOSIS

##### With CONSULT-III

- Turn the ignition switch from OFF to ON.
- Perform RAS control unit self-diagnosis.

##### Without CONSULT-III

- Start the engine.
- Perform the self-diagnosis. Refer to [STC-35, "Diagnosis Description"](#).

Is DTC "C1920" or "RAS warning lamp flickering pattern:22" detected?

- YES >> Replace RAS control unit. Refer to [STC-106, "Exploded View"](#).  
NO >> GO TO 4.



# C1920 STEERING ANGLE SENSOR

< DTC/CIRCUIT DIAGNOSIS >

[WITH REAR ACTIVE STEER]

## 4. INFORMATION CHECK

### With CONSULT-III

Check the "DATA MONITOR" value of each DTC detected with the self-diagnosis function. Refer to [STC-88](#), "Reference Value".

Is each data the standard value?

- YES >> Check that there is no malfunction in each harness connector pin terminal or disconnection.
- NO >> Replace RAS control unit. Refer to [STC-106](#), "Exploded View".

## Special Repair Requirement

INFOID:000000004066068

### BEFORE REPLACING RAS CONTROL UNIT

- Record the self-diagnosis results (history).

#### **CAUTION:**

- **Never erase the memory (history) of self-diagnosis results when replacing RAS control unit after diagnosis.**
- **Erase the memory of the self-diagnosis results (record) after printing out or recording all the values of "DATA MONITOR".**

A  
B  
C  
D  
E  
F  
H  
I  
J  
K  
L  
M  
N  
O  
P

STC

# C1921 ENGINE SPEED SIGNAL

< DTC/CIRCUIT DIAGNOSIS >

[WITH REAR ACTIVE STEER]

## C1921 ENGINE SPEED SIGNAL

### Description

INFOID:000000003826450

The engine speed signal is transmitted to RAS control unit via CAN communication.

### DTC Logic

INFOID:000000003826451

### DTC DETECTION LOGIC

DTC	Display items	Malfunction detected condition	Possible cause
C1921	ENG REV SIGNAL	Malfunction is detected in engine speed signal that is output from ECM via CAN communication. (Improper signal is input engine speed.)	<ul style="list-style-type: none"><li>• ECM</li><li>• CAN communication line</li><li>• RAS control unit</li></ul>

### DTC CONFIRMATION PROCEDURE

#### 1. DTC REPRODUCTION PROCEDURE

##### With CONSULT-III

1. Turn the ignition switch from OFF to ON.
2. Perform RAS control unit self-diagnosis.

##### Without CONSULT-III

1. Start the engine.
2. Perform the self-diagnosis. Refer to [STC-35, "Diagnosis Description"](#).

Is DTC "C1921" or "RAS warning lamp flickering pattern: 33" detected?

- YES >> Proceed to diagnosis procedure. Refer to [STC-66, "Diagnosis Procedure"](#).  
NO >> INSPECTION END

### Diagnosis Procedure

INFOID:000000003826452

#### 1. PERFORM ECM SELF-DIAGNOSIS

##### With CONSULT-III

Perform ECM self-diagnosis.

Is any error system detected?

- YES >> Check the error system.  
NO >> GO TO 2.

#### 2. PERFORM SELF-DIAGNOSIS

##### With CONSULT-III

Perform RAS control unit self-diagnosis.

Is DTC "U1000" or "U1010" detected?

- YES >> Check the error system.  
NO >> GO TO 3.

#### 3. PERFORM SELF-DIAGNOSIS

##### With CONSULT-III

1. Turn the ignition switch from OFF to ON.
2. Perform RAS control unit self-diagnosis.

##### Without CONSULT-III

1. Start the engine.
2. Perform the self-diagnosis. Refer to [STC-35, "Diagnosis Description"](#).

Is DTC "C1921" or "RAS warning lamp flickering pattern: 33" detected?

- YES >> Replace RAS control unit. Refer to [STC-106, "Exploded View"](#).  
NO >> GO TO 4.

#### 4. INFORMATION CHECK

# C1921 ENGINE SPEED SIGNAL

< DTC/CIRCUIT DIAGNOSIS >

[WITH REAR ACTIVE STEER]

## ④ With CONSULT-III

Check the "DATA MONITOR" value of each DTC detected with the self-diagnosis function. Refer to [STC-88](#), "Reference Value".

Is each data the standard value?

- YES >> Check that there is no malfunction in each harness connector pin terminal or disconnection.
- NO >> Replace RAS control unit. Refer to [STC-106](#), "Exploded View".

## Special Repair Requirement

INFOID:000000004066069

### BEFORE REPLACING RAS CONTROL UNIT

- Record the self-diagnosis results (history).

#### **CAUTION:**

- **Never erase the memory (history) of self-diagnosis results when replacing RAS control unit after diagnosis.**
- **Erase the memory of the self-diagnosis results (record) after printing out or recording all the values of "DATA MONITOR".**

A  
B  
C  
D  
E  
F  
H  
I  
J  
K  
L  
M  
N  
O  
P

STC

# C1923 STEERING ANGLE SENSOR

< DTC/CIRCUIT DIAGNOSIS >

[WITH REAR ACTIVE STEER]

## C1923 STEERING ANGLE SENSOR

### Description

INFOID:000000003826454

Steering angle sensor signal is transmitted from steering angle sensor to RAS control unit via CAN communication.

### DTC Logic

INFOID:000000003826455

### DTC DETECTION LOGIC

DTC	Display items	Malfunction detected condition	Possible cause
C1923	STEERING ANGLE SEN [NO CHANGE]	Malfunction is detected in steering angle sensor signal that is output from steering angle sensor via CAN communication. [Steering angle sensor input signal error is detected when driving at 60 km/h (37 MPH) or more.]	<ul style="list-style-type: none"><li>Steering angle sensor</li><li>CAN communication line</li><li>RAS control unit</li></ul>

### DTC CONFIRMATION PROCEDURE

#### 1. DTC REPRODUCTION PROCEDURE

##### With CONSULT-III

- Drive at 60 km/h (37 MPH) or more for 3 minutes or more.
- Perform RAS control unit self-diagnosis.

##### Without CONSULT-III

- Drive at 60 km/h (37 MPH) or more for 3 minutes or more.
- Perform the self-diagnosis. Refer to [STC-35. "Diagnosis Description"](#).

Is DTC "C1923" or "RAS warning lamp flickering pattern: 22" detected?

- YES >> Proceed to diagnosis procedure. Refer to [STC-68. "Diagnosis Procedure"](#).  
NO >> INSPECTION END

### Diagnosis Procedure

INFOID:000000003826456

#### 1. PERFORM ABS ACTUATOR AND ELECTRIC UNIT (CONTROL UNIT) SELF-DIAGNOSIS

##### With CONSULT-III

- Drive at 60 km/h (37 MPH) or more for 3 minutes or more.
- Perform ABS actuator and electric unit (control unit) self-diagnosis.

Is any error system detected?

- YES >> Check the error system.  
NO >> GO TO 2.

#### 2. PERFORM SELF-DIAGNOSIS

##### With CONSULT-III

Perform RAS control unit self-diagnosis.

Is DTC "U1000" or "U1010" detected?

- YES >> Check the error system.  
NO >> GO TO 3.

#### 3. PERFORM SELF-DIAGNOSIS

##### With CONSULT-III

- Drive at 60 km/h (37 MPH) or more for 3 minutes or more.
- Perform RAS control unit self-diagnosis.

##### Without CONSULT-III

- Drive at 60 km/h (37 MPH) or more for 3 minutes or more.
- Perform the self-diagnosis. Refer to [STC-35. "Diagnosis Description"](#).

Is DTC "C1923" or "RAS warning lamp flickering pattern: 22" detected?

- YES >> Replace RAS control unit. Refer to [STC-106. "Exploded View"](#).

# C1923 STEERING ANGLE SENSOR

[WITH REAR ACTIVE STEER]

< DTC/CIRCUIT DIAGNOSIS >

NO >> GO TO 4.

## 4. INFORMATION CHECK

### With CONSULT-III

Check the "DATA MONITOR" value of each DTC detected with the self-diagnosis function. Refer to [STC-88](#), "Reference Value".

Is each data the standard value?

YES >> Check that there is no malfunction in each harness connector pin terminal or disconnection.

NO >> Replace RAS control unit. Refer to [STC-106](#), "Exploded View".

## Special Repair Requirement

INFOID:000000004066070

### BEFORE REPLACING RAS CONTROL UNIT

- Record the self-diagnosis results (history).

#### **CAUTION:**

- Never erase the memory (history) of self-diagnosis results when replacing RAS control unit after diagnosis.
- Erase the memory of the self-diagnosis results (record) after printing out or recording all the values of "DATA MONITOR".

STC

H

I

J

K

L

M

N

O

P

# C1924 STEERING ANGLE SENSOR

< DTC/CIRCUIT DIAGNOSIS >

[WITH REAR ACTIVE STEER]

## C1924 STEERING ANGLE SENSOR

### Description

INFOID:000000003826458

Steering angle sensor signal is transmitted from steering angle sensor to RAS control unit via CAN communication.

### DTC Logic

INFOID:000000003826459

### DTC DETECTION LOGIC

DTC	Display items	Malfunction detected condition	Possible cause
C1924	STEERING ANGLE SEN [NO NEUT STATE]	Driving continuously at 10 km (6 MPH) or more while the steering angle sensor value is not L10° - R10°.	<ul style="list-style-type: none"><li>Steering angle sensor</li><li>CAN communication line</li><li>RAS control unit</li></ul>

### DTC CONFIRMATION PROCEDURE

#### 1. DTC REPRODUCTION PROCEDURE

##### With CONSULT-III

- Turn the ignition switch from OFF to ON.
- Perform RAS control unit self-diagnosis.

##### Without CONSULT-III

- Start the engine.
- Perform the self-diagnosis. Refer to [STC-35, "Diagnosis Description"](#).

Is DTC "C1924" or "RAS warning lamp flickering pattern: 22" detected?

- YES >> Proceed to diagnosis procedure. Refer to [STC-70, "Diagnosis Procedure"](#).  
NO >> INSPECTION END

### Diagnosis Procedure

INFOID:000000003826460

#### 1. CHECK DRIVING

Drive for a short time.

Does the vehicle drive with front wheels in the straight-ahead position?

- YES >> GO TO 2.  
NO >> Adjust the wheel alignment. Refer to [FSU-26, "Inspection"](#).

#### 2. PERFORM SELF-DIAGNOSIS OF ABS ACTUATOR AND ELECTRIC UNIT (CONTROL UNIT)

##### With CONSULT-III

Perform ABS actuator and electric unit (control unit) self-diagnosis.

Is malfunction detected?

- YES >> Check malfunctioning circuit.  
NO >> GO TO 3.

#### 3. PERFORM SELF-DIAGNOSIS

##### With CONSULT-III

Perform RAS control unit self-diagnosis.

Is DTC "U1000" or "U1010" detected?

- YES >> Check malfunctioning circuit.  
NO >> GO TO 4.

#### 4. PERFORM SELF-DIAGNOSIS

##### With CONSULT-III

- Turn the ignition switch from OFF to ON.
- Perform RAS control unit self-diagnosis.

# C1924 STEERING ANGLE SENSOR

< DTC/CIRCUIT DIAGNOSIS >

[WITH REAR ACTIVE STEER]

## ⊗ Without CONSULT-III

1. Start the engine.
2. Perform the self-diagnosis. Refer to [STC-35, "Diagnosis Description"](#).

Is DTC "C1924" or "RAS warning lamp flickering pattern: 22" detected?

- YES >> Replace RAS control unit. Refer to [STC-106, "Exploded View"](#).  
NO >> GO TO 5.

## 5.CHECK INFORMATION

## Ⓜ With CONSULT-III

Check the "DATA MONITOR" value of each DTC detected with the self-diagnosis function. Refer to [STC-88, "Reference Value"](#).

Is each data standard?

- YES >> Check pin terminal and connection of each harness connector for non-standard conditions.  
NO >> Replace RAS control unit. Refer to [STC-106, "Exploded View"](#).

## Special Repair Requirement

INFOID:000000004066071

## BEFORE REPLACING RAS CONTROL UNIT

- Record the self-diagnosis results (history).

### CAUTION:

- **Never erase the memory (history) of self-diagnosis results when replacing RAS control unit after diagnosis.**
- **Erase the memory of the self-diagnosis results (record) after printing out or recording all the values of "DATA MONITOR".**

A  
B  
C  
D  
E  
F  
H  
I  
J  
K  
L  
M  
N  
O  
P

STC

# C1926 STEERING ANGLE SENSOR

< DTC/CIRCUIT DIAGNOSIS >

[WITH REAR ACTIVE STEER]

## C1926 STEERING ANGLE SENSOR

### Description

INFOID:000000003826462

Steering angle sensor signal is transmitted from steering angle sensor to RAS control unit via CAN communication.

### DTC Logic

INFOID:000000003826463

### DTC DETECTION LOGIC

DTC	Display items	Malfunction detected condition	Possible cause
C1926	STEERING ANGLE SEN	Malfunction is detected in steering angle sensor signal that is output from steering angle sensor via CAN communication. (When steering angle sensor signal is improper, the steering angle sensor itself detects the malfunction)	<ul style="list-style-type: none"><li>Steering angle sensor</li><li>CAN communication line</li><li>RAS control unit</li></ul>

### DTC CONFIRMATION PROCEDURE

#### 1. DTC REPRODUCTION PROCEDURE

##### With CONSULT-III

1. Start the engine.

**CAUTION:**

**Stop the vehicle.**

- Turn the steering wheel leftward slowly. Steer until the turning stops.
- Turn the steering wheel rightward slowly. Steer to the straight-forward position.
- Perform RAS control unit self-diagnosis.

##### Without CONSULT-III

1. Start the engine.

**CAUTION:**

**Stop the vehicle.**

- Turn the steering wheel leftward slowly. Steer until the turning stops.
- Turn the steering wheel rightward slowly. Steer to the straight-forward position.
- Perform the self-diagnosis. Refer to [STC-35, "Diagnosis Description"](#).

Is DTC "C1926" or "RAS warning lamp flickering pattern: 22" detected?

YES >> Proceed to diagnosis procedure. Refer to [STC-72, "Diagnosis Procedure"](#).

NO >> INSPECTION END

### Diagnosis Procedure

INFOID:000000003826464

#### 1. PERFORM ABS ACTUATOR AND ELECTRIC UNIT (CONTROL UNIT) SELF-DIAGNOSIS

##### With CONSULT-III

Perform ABS actuator and electrical unit (control unit) self-diagnosis.

Is any error system detected?

YES >> Check the error system.

NO >> GO TO 2.

#### 2. PERFORM SELF-DIAGNOSIS

##### With CONSULT-III

Perform RAS control unit self-diagnosis

Is DTC "U1000" or "U1010" detected?

YES >> Check the error system.

NO >> GO TO 3.

#### 3. PERFORM SELF-DIAGNOSIS

##### With CONSULT-III



# C1926 STEERING ANGLE SENSOR

< DTC/CIRCUIT DIAGNOSIS >

[WITH REAR ACTIVE STEER]

1. Start the engine.  
**CAUTION:**  
**Stop the vehicle.**
2. Turn the steering wheel leftward slowly. Steer until the turning stops.
3. Turn the steering wheel rightward slowly. Steer to the straight-forward position.
4. Perform RAS control unit self-diagnosis.

**⊗ Without CONSULT-III**

1. Start the engine.  
**CAUTION:**  
**Stop the vehicle.**
2. Turn the steering wheel leftward slowly. Steer until the turning stops.
3. Turn the steering wheel rightward slowly. Steer to the straight-forward position.
4. Perform the self-diagnosis. Refer to [STC-35, "Diagnosis Description"](#).

Is DTC "C1926" or "RAS warning lamp flickering pattern: 22" detected?

- YES >> Replace RAS control unit. Refer to [STC-106, "Exploded View"](#).  
NO >> GO TO 4.

## 4. INFORMATION CHECK

**Ⓜ With CONSULT-III**

Check the "DATA MONITOR" value of each DTC detected with the self-diagnosis function. Refer to [STC-88, "Reference Value"](#).

Is each data the standard value?

- YES >> Check that there is no malfunction in each harness connector pin terminal or disconnection.  
NO >> Replace RAS control unit. Refer to [STC-106, "Exploded View"](#).

## Special Repair Requirement

INFOID:000000004066072

### BEFORE REPLACING RAS CONTROL UNIT

- Record the self-diagnosis results (history).  
**CAUTION:**
  - **Never erase the memory (history) of self-diagnosis results when replacing RAS control unit after diagnosis.**
  - **Erase the memory of the self-diagnosis results (record) after printing out or recording all the values of "DATA MONITOR".**

A  
B  
C  
D  
E  
F  
STC  
H  
I  
J  
K  
L  
M  
N  
O  
P

# C1929 ABS ACTUATOR AND ELECTRIC UNIT (CONTROL UNIT)

< DTC/CIRCUIT DIAGNOSIS >

[WITH REAR ACTIVE STEER]

## C1929 ABS ACTUATOR AND ELECTRIC UNIT (CONTROL UNIT)

### Description

INFOID:000000003843894

The ABS actuator and electric unit (control unit) and the RAS control unit exchange signals via the CAN communication line.

### DTC Logic

INFOID:000000003843884

### DTC DETECTION LOGIC

DTC	Display items	Malfunction detected condition	Possible cause
C1929	VDC	Malfunction is detected in VDC malfunction signal that is output from ABS actuator and electric unit (control unit) via CAN communication. (VDC malfunction signal is improper.)	<ul style="list-style-type: none"><li>• ABS actuator and electric unit (control unit)</li><li>• CAN communication</li><li>• RAS control unit</li></ul>

### DTC CONFIRMATION PROCEDURE

#### 1. DTC REPRODUCTION PROCEDURE

##### With CONSULT-III

1. Turn the ignition switch from OFF to ON.
2. Perform RAS control unit self-diagnosis.

##### Without CONSULT-III

1. Start the engine.
2. Perform the self-diagnosis. Refer to [STC-35, "Diagnosis Description"](#).

Is DTC "C1929" or "RAS warning lamp flickering pattern:26" detected?

- YES >> Proceed to diagnosis procedure. Refer to [STC-74, "Diagnosis Procedure"](#).  
NO >> INSPECTION END

### Diagnosis Procedure

INFOID:000000003843885

#### 1. PERFORM ABS ACTUATOR AND ELECTRIC UNIT (CONTROL UNIT) SELF-DIAGNOSIS

##### With CONSULT-III

Perform ABS actuator and electrical unit (control unit) self-diagnosis.

Is any error system detected?

- YES >> Check the error system.  
NO >> GO TO 2.

#### 2. PERFORM SELF-DIAGNOSIS

##### With CONSULT-III

Perform RAS control unit self-diagnosis.

Is DTC "U1000" or "U1010" detected?

- YES >> Check the error system.  
NO >> GO TO 3.

#### 3. PERFORM SELF-DIAGNOSIS

##### With CONSULT-III

1. Turn the ignition switch from OFF to ON.
2. Perform RAS control unit self-diagnosis.

##### Without CONSULT-III

1. Start the engine.
2. Perform the self-diagnosis. Refer to [STC-35, "Diagnosis Description"](#).

Is DTC "C1929" or "RAS warning lamp flickering pattern:26" detected?

- YES >> Replace RAS control unit. Refer to [STC-106, "Exploded View"](#).  
NO >> GO TO 4.

# C1929 ABS ACTUATOR AND ELECTRIC UNIT (CONTROL UNIT)

< DTC/CIRCUIT DIAGNOSIS >

[WITH REAR ACTIVE STEER]

## 4. INFORMATION CHECK

### With CONSULT-III

Check the "DATA MONITOR" value of each DTC detected with the self-diagnosis function. Refer to [STC-88](#), "Reference Value".

Is each data the standard value?

YES >> Check that there is no malfunction in each harness connector pin terminal or disconnection.

NO >> Replace RAS control unit. Refer to [STC-106](#), "Exploded View".

## Special Repair Requirement

INFOID:000000004066077

### BEFORE REPLACING RAS CONTROL UNIT

- Record the self-diagnosis results (history).

#### **CAUTION:**

- Never erase the memory (history) of self-diagnosis results when replacing RAS control unit after diagnosis.
- Erase the memory of the self-diagnosis results (record) after printing out or recording all the values of "DATA MONITOR".

A  
B  
C  
D  
E  
F  
H  
I  
J  
K  
L  
M  
N  
O  
P

STC

# U1000 CAN COMM CIRCUIT

< DTC/CIRCUIT DIAGNOSIS >

[WITH REAR ACTIVE STEER]

## U1000 CAN COMM CIRCUIT

### Description

INFOID:000000003826475

CAN (Controller Area Network) is a serial communication line for real time application. It is an on-vehicle multiplex communication line with high data communication speed and excellent error detection ability. Many electronic control units are equipped onto a vehicle, and each control unit shares information and links with other control units during operation (not independent). In CAN communication, control units are connected with 2 communication lines (CAN-H line, CAN-L line) allowing a high rate of information transmission with less wiring. Each control unit transmits/receives data but selectively reads required data only.

### DTC Logic

INFOID:000000003826476

### DTC DETECTION LOGIC

DTC	Display items	Malfunction detected condition	Possible cause
U1000	CAN COMM CIRCUIT	When RAS control unit is not transmitting or receiving CAN communication signal for 2 seconds or more.	<ul style="list-style-type: none"><li>CAN communication line</li><li>RAS control unit</li></ul>

### DTC CONFIRMATION PROCEDURE

#### 1. DTC REPRODUCTION PROCEDURE

##### Ⓢ With CONSULT-III

- Turn the ignition switch from OFF to ON.
- Perform RAS control unit self-diagnosis.

##### Is DTC "U1000" detected?

- YES >> Proceed to diagnosis procedure. Refer to [STC-76, "Diagnosis Procedure"](#).  
NO >> INSPECTION END

### Diagnosis Procedure

INFOID:000000004066084

#### 1. PERFORM SELF-DIAGNOSIS

Perform RAS control unit self-diagnosis.

##### Is DTC "U1000" detected?

- YES >> Perform CAN diagnosis. Refer to [LAN-31, "CAN System Specification Chart"](#).  
NO >> INSPECTION END

### Special Repair Requirement

INFOID:000000004066084

#### BEFORE REPLACING RAS CONTROL UNIT

- Record the self-diagnosis results (history).

##### CAUTION:

- Never erase the memory (history) of self-diagnosis results when replacing RAS control unit after diagnosis.
- Erase the memory of the self-diagnosis results (record) after printing out or recording all the values of "DATA MONITOR".

# U1010 CONTROL UNIT (CAN)

< DTC/CIRCUIT DIAGNOSIS >

[WITH REAR ACTIVE STEER]

## U1010 CONTROL UNIT (CAN)

### Description

INFOID:000000003826479

CAN (Controller Area Network) is a serial communication line for real time application. It is an on-vehicle multiplex communication line with high data communication speed and excellent error detection ability. Many electronic control units are equipped onto a vehicle, and each control unit shares information and links with other control units during operation (not independent). In CAN communication, control units are connected with 2 communication lines (CAN-H line, CAN-L line) allowing a high rate of information transmission with less wiring. Each control unit transmits/receives data but selectively reads required data only.

### DTC Logic

INFOID:000000003826480

### DTC DETECTION LOGIC

DTC	Display items	Malfunction detected condition	Possible cause
U1010	CONTROL UNIT (CAN)	Detecting error during the initial diagnosis of CAN controller of RAS control unit.	Malfunction of RAS control unit

### DTC CONFIRMATION PROCEDURE

#### 1. DTC REPRODUCTION PROCEDURE

##### Ⓜ With CONSULT-III

1. Turn the ignition switch from OFF to ON.
2. Perform RAS control unit self-diagnosis.

##### Is DTC "U1010" detected?

- YES >> Proceed to diagnosis procedure. Refer to [STC-77, "Diagnosis Procedure"](#).  
NO >> INSPECTION END

### Diagnosis Procedure

INFOID:000000003826481

#### 1. RAS CONTROL UNIT

Check that there is no malfunction in RAS control unit harness connector or disconnection.

##### Is the inspection result normal?

- YES >> Replace RAS control unit. Refer to [STC-106, "Exploded View"](#).  
NO >> Repair or replace damaged parts.

### Special Repair Requirement

INFOID:000000004066089

#### BEFORE REPLACING RAS CONTROL UNIT

- Record the self-diagnosis results (history).

##### CAUTION:

- **Never erase the memory (history) of self-diagnosis results when replacing RAS control unit after diagnosis.**
- **Erase the memory of the self-diagnosis results (record) after printing out or recording all the values of "DATA MONITOR".**

# POWER SUPPLY AND GROUND CIRCUIT

< DTC/CIRCUIT DIAGNOSIS >

[WITH REAR ACTIVE STEER]

## POWER SUPPLY AND GROUND CIRCUIT

### Description

INFOID:000000003940853

Supplies power to RAS control unit.

### Diagnosis Procedure

INFOID:000000003826485

#### 1. CHECK RAS CONTROL UNIT POWER SUPPLY

1. Turn the ignition switch OFF.
2. Disconnect RAS control unit harness connector.
3. Check the voltage between RAS control unit harness connectors and ground.

RAS control unit		—	Voltage (Approx.)
Connector	Terminal		
B37	27	Ground	0 V

4. Turn the ignition switch ON.  
**CAUTION:**  
**Never start the engine.**
5. Check the voltage between RAS control unit harness connectors and the ground.

RAS control unit		—	Voltage (Approx.)
Connector	Terminal		
B37	27	Ground	Battery voltage

Is the inspection result normal?

YES >> GO TO 2.

NO >> Check the following items. Repair or replace the malfunctioning parts.

- 10A fuse (#45) open
- Short among 10A fuse (#45) connector, RAS control unit harness connector No. 27 terminal and the ground
- Open between the ignition switch and RAS control unit harness connector No. 27 terminal
- Ignition switch

#### 2. CHECK RAS MOTOR POWER SUPPLY CIRCUIT (1)

1. Turn the ignition switch OFF.
2. Remove RAS motor relay.
3. Check the continuity between RAS motor relay harness connector and ground.

RAS motor relay		—	Continuity
Connector	Terminal		
B36	1	Ground	Existed
	2		Not existed

Is the inspection result normal?

YES >> GO TO 3.

NO >> Repair or replace the harnesses and connectors.

#### 3. CHECK RAS MOTOR POWER SUPPLY CIRCUIT (2)

Check the voltage between RAS motor relay harness connector and ground.

RAS motor relay		—	Voltage (Approx.)
Connector	Terminal		
B36	3	Ground	Battery voltage

Is the inspection result normal?

# POWER SUPPLY AND GROUND CIRCUIT

[WITH REAR ACTIVE STEER]

< DTC/CIRCUIT DIAGNOSIS >

YES >> GO TO 4.

NO >> Check the following items. Repair or replace the malfunctioning parts.

- 20A fuse (#37) open
- Short among 20A fuse (#37) connector, RAS motor relay harness connector No. 3 terminal and the ground
- Open between the battery and RAS motor relay harness connector No. 3 terminal

## 4. CHECK RAS MOTOR POWER SUPPLY CIRCUIT (3)

1. Remove the noise suppressor.
2. Check the continuity between the noise suppressor harness connector and ground.

Noise suppressor		—	Continuity
Connector	Terminal		
B39	3	Ground	Not existed
	5		
B40	1		Not existed
	2		Existed

Is the inspection result normal?

YES >> GO TO 5.

NO >> Repair or replace the harnesses and connectors.

## 5. CHECK RAS MOTOR POWER SUPPLY CIRCUIT (4)

1. Connect RAS control unit harness connector.
2. Turn the ignition switch ON.  
**CAUTION:**  
**Never start the engine.**
3. Check the voltage between RAS control unit harness connector and ground.

RAS control unit		—	Voltage (Approx.)
Connector	Terminal		
B37	25	Ground	Battery voltage

4. Turn the ignition switch OFF.

Is the inspection result normal?

YES >> GO TO 6.

NO >> Replace RAS control unit. Refer to [STC-106. "Exploded View"](#).

## 6. CHECK RAS MOTOR RELAY

1. Apply 12 V to RAS motor relay connector No. 1 terminal and No. 2 terminal.

**CAUTION:**

- **Never make the terminals short.**
- **Connect the fuse between the terminals when applying the voltage.**

2. Check the continuity between RAS motor relay connector terminals.

RAS motor relay			Continuity
Connector	Terminal		
B36	3	5	Apply the voltage between No. 1 terminal and No. 2 terminal. Existed
			Do not apply the voltage between No. 1 terminal and No. 2 terminal. Not existed

3. Check the resistance between RAS motor relay connector terminals.

# POWER SUPPLY AND GROUND CIRCUIT

< DTC/CIRCUIT DIAGNOSIS >

[WITH REAR ACTIVE STEER]

RAS motor relay			Resistance (Approx.)
Connector	Terminal		
B36	1	2	50 Ω

Is the inspection result normal?

YES >> GO TO 7.

NO >> Replace RAS motor relay.

## 7.CHECK NOISE SUPPRESSOR

Check continuity between the noise suppressor connector terminals.

Noise suppressor				Continuity
Connector	Terminal	Connector	Terminal	
B39	3	B40	1	Existed
	3	B39	5	Not existed
	3	B40	2	Not existed
	5	B40	2	Existed
	5	B40	1	Not existed

Is the inspection result normal?

YES >> GO TO 8.

NO >> Replace the noise suppressor.

## 8.CHECK RAS MOTOR POWER SUPPLY

1. Connect RAS control unit harness connector.
2. Install RAS motor relay.
3. Install the noise suppressor.
4. Turn the ignition switch ON.  
**CAUTION:**  
**Never start the engine.**
5. Check the voltage between RAS control unit harness connectors and ground.

RAS control unit		—	Voltage (Approx.)
Connector	Terminal		
B37	37	Ground	Battery voltage

Is the inspection result normal?

YES >> INSPECTION END

NO >> Replace RAS control unit. Refer to [STC-106. "Exploded View"](#).

## Component Inspection (RAS Motor Relay)

INFOID:000000003826486

### 1.CHECK RAS MOTOR RELAY

1. Turn the ignition switch OFF.
2. Remove RAS motor relay connector.
3. Apply 12 V to RAS motor relay connector No. 1 terminal and No. 2 terminal.  
**CAUTION:**
  - Never make the terminals short.
  - Connect the fuse between the terminals when applying the voltage.
4. Check the continuity between RAS motor relay connector terminals.



# POWER SUPPLY AND GROUND CIRCUIT

< DTC/CIRCUIT DIAGNOSIS >

[WITH REAR ACTIVE STEER]

RAS motor relay			Continuity
Connector	Terminal		
B36	3	5	Apply the voltage between No. 1 terminal and No. 2 terminal.
			Do not apply the voltage between No. 1 terminal and No. 2 terminal.

5. Check the resistance between RAS motor relay connector terminals.

RAS motor relay			Resistance (Approx.)
Connector	Terminal		
B36	1	2	50 Ω

Is the inspection result normal?

- YES >> INSPECTION END  
 NO >> Replace RAS motor relay.

## Component Inspection (Noise Suppressor)

INFOID:000000003826487

### 1. NOISE SUPPRESSOR INSPECTION

- Turn the ignition switch OFF.
- Remove the noise suppressor.
- Check continuity between the noise suppressor connector terminals.

Noise suppressor				Continuity
Connector	Terminal	Connector	Terminal	
B39	3	B40	1	Existed
	3	B39	5	Not existed
	3	B40	2	Not existed
	5	B40	2	Existed
	5	B40	1	Not existed

Is the inspection result normal?

- YES >> INSPECTION END  
 NO >> Replace the noise suppressor.

A  
B  
C  
D  
E  
F  
STC  
H  
I  
J  
K  
L  
M  
N  
O  
P

# POWER STEERING SOLENOID VALVE

< DTC/CIRCUIT DIAGNOSIS >

[WITH REAR ACTIVE STEER]

## POWER STEERING SOLENOID VALVE

### Description

INFOID:000000003826488

The power steering oil pressure in the gear housing assembly is controlled.

### Diagnosis Procedure

INFOID:000000003826489

#### 1. CHECK POWER STEERING SOLENOID VALVE SIGNAL

##### With CONSULT-III

1. Start the engine.
2. Check "POWER STR SOL" item on "DATA MONITOR" of RAS control unit.

Monitor item	Condition	Display value
POWER STR SOL	Vehicle speed: 0 km/h (0 MPH) (Engine is running)	Approx. 1.10 A
	Vehicle speed: 100 km/h (62 MPH)	Approx. 0.42 A

##### Without CONSULT-III

1. Start the engine.
2. Check the voltage between RAS control unit harness connector and ground.

RAS control unit				Data (Approx.)
Connector	Terminal	—	Condition	
B37	36	Ground	Vehicle speed: 0 km/h (0 MPH) (Engine is running)	4.4 – 6.6 V
			Vehicle speed: 100 km/h (62 MPH)	2.4 – 3.6 V

3. Check that there is no malfunction in RAS control unit harness connector or disconnection.

Is the inspection result normal?

YES >> GO TO 2.

NO >> Replace RAS control unit. Refer to [STC-106, "Exploded View"](#).

#### 2. CHECK POWER STEERING SOLENOID VALVE CIRCUIT

1. Turn the ignition switch OFF.
2. Disconnect RAS control unit harness connector.
3. Disconnect the power steering solenoid valve harness connector.
4. Check the continuity between RAS control unit harness connector and power steering solenoid valve harness connector.

RAS control unit		Power steering solenoid valve		Continuity
Connector	Terminal	Connector	Terminal	
B37	36	F45	1	Existed

5. Check the continuity between power steering solenoid valve harness connector and ground.

Power steering solenoid valve		—	Continuity
Connector	Terminal		
F45	2	Ground	Existed

Is the inspection result normal?

YES >> GO TO 3.

NO >> Repair or replace the harnesses and connectors.

#### 3. CHECK POWER STEERING SOLENOID VALVE

Check the power steering solenoid valve. Refer to [STC-83, "Component Inspection"](#).

# POWER STEERING SOLENOID VALVE

[WITH REAR ACTIVE STEER]

< DTC/CIRCUIT DIAGNOSIS >

Is the inspection result normal?

YES >> INSPECTION END

NO >> Repair the steering gear. Refer to [ST-25, "Exploded View"](#).

## Component Inspection

INFOID:000000003826490

### 1. POWER STEERING SOLENOID VALVE INSPECTION

1. Turn the ignition switch OFF.
2. Disconnect the power steering solenoid valve harness connector.
3. Check the resistance between power steering solenoid valve connector terminals.

Power steering solenoid valve		—	Resistance (Approx.)
Connector	Terminal		
F45	1	Ground	4 – 6 Ω

4. Check for click sound (power steering solenoid valve activation sound) when applying approximately 12 V between the power steering solenoid valve connector terminals.

**CAUTION:**

- Never make the terminals short.
- Assign the positive terminal to No. 1 terminal, and the negative terminal to No. 2 terminal. Connect the fuse between the terminals when applying the voltage.

Is the inspection result normal?

YES >> INSPECTION END

NO >> Repair the steering gear. Refer to [ST-25, "Exploded View"](#).

A  
B  
C  
D  
E  
F  
STC  
H  
I  
J  
K  
L  
M  
N  
O  
P

# RAS WARNING LAMP

[WITH REAR ACTIVE STEER]

< DTC/CIRCUIT DIAGNOSIS >

## RAS WARNING LAMP

### Description

INFOID:000000003826491

- RAS warning lamp turns ON when ignition switch turns ON from OFF. Then, RAS warning lamp turns OFF after the engine is started.
- The check of RAS system is performed.
- RAS system stops (error) when RAS warning lamp turns ON.

### Component Function Check

INFOID:000000003901524

#### 1. CHECK RAS WARNING LAMP FUNCTION

1. Turn ignition switch ON.
2. Make sure that RAS warning lamp lights up.

Is the inspection result normal?

YES >> INSPECTION END

NO >> Proceed to diagnosis procedure. Refer to [STC-84, "Diagnosis Procedure"](#).

### Diagnosis Procedure

INFOID:000000003826492

#### 1. PERFORM UNIFIED METER AND A/C AMP. SELF-DIAGNOSIS

 **With CONSULT-III**

Perform the self-diagnosis of the unified meter and A/C amp.

Is any error system detected?

YES >> Check the error system.

NO >> GO TO 2.

#### 2. PERFORM SELF-DIAGNOSIS

 **With CONSULT-III**

Perform RAS control unit self-diagnosis.

Is DTC "U1000" or "U1010" detected?

YES >> Check the error system.

NO >> GO TO 3.

#### 3. PERFORM COMBINATION METER CIRCUIT

1. Turn the ignition switch OFF.
2. Disconnect the unified meter and A/C amp. harness connector.
3. Disconnect the combination meter harness connector.
4. Check the continuity between the unified meter and A/C amp. harness connector and the combination meter harness connector terminal.

Unified meter and A/C amp.		Combination meter		Continuity
Connector	Terminal	Connector	Terminal	
M66	7	M53	3	Existed
M66	27	M53	2	

Is the inspection result normal?

YES >> GO TO 4.

NO >> Repair or replace the harnesses and connectors.

#### 4. CHECK RAS WARNING LAMP SIGNAL

 **With CONSULT-III**

1. Connect the unified meter and A/C amp. harness connector.
2. Connect the combination meter harness connector.
3. Turn the ignition switch ON.

**CAUTION:**

**Never start the engine.**

# RAS WARNING LAMP

[WITH REAR ACTIVE STEER]

< DTC/CIRCUIT DIAGNOSIS >

4. Check "WARNING LAMP" item on DATA MONITOR of RAS control unit.

Does the item on "DATA MONITOR" indicate "On"?

YES >> GO TO 5.

NO >> Replace RAS control unit. Refer to [STC-106, "Exploded View"](#).

## 5. CHECK COMBINATION METER

 **With CONSULT-III**

Perform the trouble diagnosis of the combination meter. Refer to [MWI-43, "Diagnosis Description"](#).

Is the inspection result normal?

YES >> INSPECTION END

NO >> Replace the combination meter. Refer to [MWI-174, "Exploded View"](#).

## Special Repair Requirement

INFOID:000000004066090

### BEFORE REPLACING RAS CONTROL UNIT

- Record the self-diagnosis results (history).

**CAUTION:**

- Never erase the memory (history) of self-diagnosis results when replacing RAS control unit after diagnosis.**
- Erase the memory of the self-diagnosis results (record) after printing out or recording all the values of "DATA MONITOR".**

STC

H

I

J

K

L

M

N

O

P

# STOP LAMP SWITCH

[WITH REAR ACTIVE STEER]

< DTC/CIRCUIT DIAGNOSIS >

## STOP LAMP SWITCH

### Description

INFOID:000000003901571

The stop lamp switch transmits the stop lamp switch signal (ON/OFF) to the RAS control unit.

### Component Function Check

INFOID:000000003940987

#### 1.CHECK STOP LAMP SWITCH OPERATION

Operate the brake pedal. Then check that the stop lamp in the rear combination lamp turns ON/OFF correctly.

Condition	Stop lamp illumination status
When the brake pedal is operation	ON
When the brake pedal is not operation.	OFF

Is the inspection result normal?

YES >> INSPECTION END

NO >> Proceed to diagnosis procedure. Refer to [STC-86, "Diagnosis Procedure"](#).

### Diagnosis Procedure

INFOID:000000003901553

#### 1.CHECK CONNECTOR

1. Turn the ignition switch OFF.
2. Disconnect RAS control unit harness connector.
3. Disconnect stop lamp switch harness connector.
4. Check terminal for deformation, disconnection, looseness, etc.

Is the inspection result normal?

YES >> GO TO 2.

NO >> Replace or repair damaged parts.

#### 2.CHECK STOP LAMP SWITCH

Check stop lamp switch. Refer to [STC-86, "Component Inspection"](#).

Is the inspection result normal?

YES >> GO TO 3.

NO >> Repair or replace stop lamp switch.

#### 3.CHECK STOP LAMP SWITCH CIRCUIT

1. Turn the ignition switch OFF.
2. Check the voltage between RAS control unit harness connector and ground.

RAS control unit		—	Condition	Voltage
Connector	Terminal			
B37	22	Ground	Brake pedal is depressed	Battery voltage
			Brake pedal is released	Approx. 0 V

Is the inspection result normal?

YES >> INSPECTION END

NO >> Repair or replace damaged parts.

### Component Inspection

INFOID:000000003901555

#### 1.CHECK STOP LAMP SWITCH

1. Turn the ignition switch OFF.
2. Disconnect stop lamp switch connector.
3. Check the continuity between stop lamp switch connector terminals.

# STOP LAMP SWITCH

< DTC/CIRCUIT DIAGNOSIS >

[WITH REAR ACTIVE STEER]

Stop lamp switch		Condition	Continuity
Connector	Terminal		
E110	3 - 4	Release stop lamp switch (When brake pedal is depressed.)	Existed
		Push stop lamp switch (When brake pedal is released.)	Not existed

Is the inspection result normal?

YES >> INSPECTION END

NO >> Replace stop lamp switch. Refer to [BR-18. "Exploded View"](#).

## Special Repair Requirement

INFOID:000000004169137

### BEFORE REPLACING RAS CONTROL UNIT

- Record the self-diagnosis results (history).

**CAUTION:**

- Never erase the memory (history) of self-diagnosis results when replacing RAS control unit after diagnosis.
- Erase the memory of the self-diagnosis results (record) after printing out or recording all the values of "DATA MONITOR".

STC

# RAS CONTROL UNIT

< ECU DIAGNOSIS INFORMATION >

[WITH REAR ACTIVE STEER]

## ECU DIAGNOSIS INFORMATION

### RAS CONTROL UNIT

Reference Value

INFOID:000000003844026

#### VALUES ON THE DIAGNOSIS TOOL

Monitor item	Content	Condition	Value/Status
VHCL SPEED SE	Wheel speed	Vehicle stopped	0 km/h (0 MPH)
		Start the engine. Wait a minute. Drive the vehicle. <b>CAUTION:</b> <b>Check air pressure of tire under standard condition.</b>	Approximately equal to the indication on speedometer (Inside of ±10%)
STEERING ANG	Steering angle detected by steering angle sensor	Steering wheel turned right	0° – R756°
		Straight-ahead	Approx. 0°
		Steering wheel turned left	0° – L756°
ENGINE SPEED	Engine speed	Engine stopped	0 rpm
		Engine running (Engine speed: 400 rpm or more)	Approximately equal to the indication on tachometer
POWER STR SOL	Monitored value of current at power steering solenoid valve	Vehicle speed: 0 km/h (0 MPH) (Engine is running)	Approx. 1.10 A
		Vehicle speed: 100 km/h (62 MPH)	Approx. 0.42 A
RR ST ANG-MAI	Rear wheel steering angle (main) sensor output voltage	RAS actuator assembly turns right completely	Approx. 4.4 V
		RAS actuator assembly is neutral	Approx. 2.4 V
		RAS actuator assembly turns left completely	Approx. 0.4 V
RR ST ANG-SUB	Rear wheel steering angle (sub) sensor output voltage	RAS actuator assembly turns right completely	Approx. 4.4 V
		RAS actuator assembly is neutral	Approx. 2.4 V
		RAS actuator assembly turns left completely	Approx. 0.4 V
RR ST ANG-VOL	Rear wheel steering angle sensor input voltage	Ignition switch: ON	Approx. 5 V
		Ignition switch: OFF	0 V
C/U VOLTAGE	Power supply voltage for RAS control unit	Ignition switch: ON	Battery voltage
		Ignition switch: OFF	—
MOTOR VOLTAGE	Monitored value of voltage at RAS motor	Ignition switch: ON	Battery voltage
		Ignition switch: OFF	0 V
MOTOR CURRENT	Monitored value of current at RAS motor	RAS motor running	Approx. 0 – 20 A
MTR CRNT OPE	Current commanded value to RAS motor	RAS motor running	Approx. –20 – 20 A
RR ANGLE OPE	Rear wheel steering angle detected by rear wheel steering angle sensor	RAS actuator assembly turned right	Approx. 0 – 1°
		RAS actuator assembly is neutral	Approx. 0°
		RAS actuator assembly turned left	Approx. 0 – –1°
STOP LAMP SW	Stop lamp condition	Brake pedal: Depressed	ON
		Brake pedal: Released	OFF
HICAS RELAY	RAS motor relay condition	Ignition switch: ON	ON
		Ignition switch: OFF	OFF



# RAS CONTROL UNIT

< ECU DIAGNOSIS INFORMATION >

[WITH REAR ACTIVE STEER]

Monitor item	Content	Condition	Value/Status
FAIL SAFE	Fail-safe condition	Fail-safe condition	ON
		Normal	OFF
WARNING LAMP	RAS warning lamp condition	RAS warning lamp: ON	ON
		RAS warning lamp: OFF	OFF

## TERMINAL LAYOUT

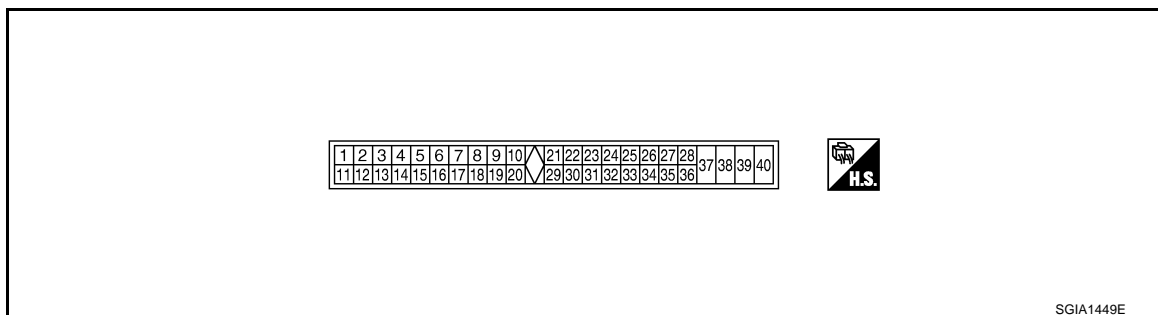

## PHYSICAL VALUES

Terminal No. (Wire color)		Description		Condition	Value (Approx.)
+	-	Signal name	Input/ Output		
1 (L)	—	CAN-H	—	—	—
4 (Y)	Ground	Rear wheel steering angle sensor (main) output voltage	Output	RAS actuator assembly turns right completely.	4.4 V
				RAS actuator assembly is neutral	2.4 V
				RAS actuator assembly turns left completely.	0.4 V
5 (W)	Ground	Rear wheel steering angle sensor power supply	Output	Ignition switch: ON	5 V
				Ignition switch: OFF	0 V
7 (R)	Ground	Rear wheel steering angle sensor (sub) output voltage	Output	RAS actuator assembly turns right completely.	4.4 V
				RAS actuator assembly is neutral	2.6 V
				RAS actuator assembly turns left completely.	0.4 V
8 (P)	—	CAN-L	—	—	—
15 (G)	Ground	Ground (Rear wheel steering angle sensor)	—	Always	0 V
22 (GR)	Ground	Stop lamp switch	Input	Brake pedal: Depressed	Battery voltage
				Brake pedal: Released	0 V
25 (SB)	Ground	RAS motor relay	Output	Ignition switch: ON	Battery voltage
				Ignition switch: OFF	0 V
27 (G)	Ground	Ignition switch	Input	Ignition switch: ON	Battery voltage
				Ignition switch: OFF	0 V
34 (GR)	Ground	Ground	—	Always	0 V

## RAS CONTROL UNIT

< ECU DIAGNOSIS INFORMATION >

[WITH REAR ACTIVE STEER]

Terminal No. (Wire color)		Description		Condition	Value (Approx.)
+	-	Signal name	Input/ Output		
36 (LG)	Ground	Power steering solenoid valve	Output	Vehicle speed: 0 km/h (0 MPH) (Engine is running)	4.4 – 6.6 V
				Vehicle speed: 100 km/h (62 MPH)	2.4 – 3.6 V
37 (P)	Ground	RAS motor power supply	Input	Ignition switch: ON	Battery voltage
				Ignition switch: OFF	0 V
38 (G/Y)	Ground	RAS motor output voltage (right)	Output	While RAS motor activates rightward	Battery voltage
				While RAS motor activates leftward	0 V
39 (G/R)	Ground	RAS motor output voltage (left)	Output	While RAS motor activates rightward	0 V
				While RAS motor activates leftward	Battery voltage
40 (B)	Ground	Ground (RAS motor)	—	Always	0 V

**CAUTION:**

When using circuit tester to measure voltage for inspection, never forcibly extend any connector terminals.



# RAS CONTROL UNIT

< ECU DIAGNOSIS INFORMATION >

[WITH REAR ACTIVE STEER]

## RAS SYSTEM

Connector No.	B1
Connector Name	WIRE TO WIRE
Connector Type	TR80FW-CS16-TM4

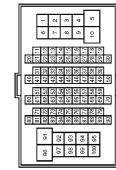

Terminal No.	Color of Wire	Signal Name [Specification]
39	B	-
40	LG	-
41	G	-
42	GR	-
50	B	-
80	L	-
81	P	-
82	L	-
83	P	-

Connector No.	B3
Connector Name	WIRE TO WIRE
Connector Type	M02FW-LC



Terminal No.	Color of Wire	Signal Name [Specification]
2	R	-

Connector No.	B35
Connector Name	RAS MOTOR RELAY
Connector Type	MS02EL-M2-LC

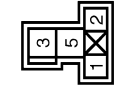

Terminal No.	Color of Wire	Signal Name [Specification]
1	GR	-
2	SB	-
3	R	-
5	L	-

Connector No.	B37
Connector Name	RAS CONTROL UNIT
Connector Type	A38FW-M4



Terminal No.	Color of Wire	Signal Name [Specification]
1	L	CAN-H
4	Y	R-ANG SEN MAIN SIG
5	W	R-ANG SEN VCC
7	R	R-ANG SEN SUB SIG
8	P	CAN-L
15	G	R-ANG SEN GND
22	G	STOP LAMP SW
25	SB	R-MTR RLY
27	G	IGN
34	GR	GND
36	LG	EPS SOL+

Connector No.	B39
Connector Name	NOISE SUPPRESSOR
Connector Type	NS02FW-CS



Terminal No.	Color of Wire	Signal Name [Specification]
1	L	-
2	B	-

Connector No.	B40
Connector Name	NOISE SUPPRESSOR
Connector Type	NS03FW-CS



Terminal No.	Color of Wire	Signal Name [Specification]
3	P	-
5	B	-



















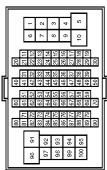





# RAS CONTROL UNIT

< ECU DIAGNOSIS INFORMATION >

[WITH REAR ACTIVE STEER]

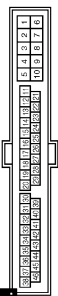
## RAS SYSTEM

Connector No.	E103	Connector No.	E106	Connector No.	E110	Connector No.	E121
Connector Name	FUSE BLOCK (J/B)	Connector Name	WIRE TO WIRE	Connector Name	STOP LAMP SWITCH	Connector Name	WIRE TO WIRE
Connector Type	NS10FW-CS	Connector Type	TH80FW-CS16-1M4	Connector Type	M04FW-LC	Connector Type	M02MW-LC
							
							
Terminal No.	2F 8F	Terminal No.	7 47 48 51 52 76	Terminal No.	1 2 3 4	Terminal No.	2
Color of Wire	W L	Color of Wire	G L P B Y L	Color of Wire	L SB L W	Color of Wire	L
Signal Name [Specification]	- -	Signal Name [Specification]	- - - - - -	Signal Name [Specification]	- - - -	Signal Name [Specification]	-
Connector No.	F45	Connector No.	F103	Connector No.	M1	Connector No.	M2
Connector Name	POWER STEERING SOLENOID VALVE	Connector Name	WIRE TO WIRE	Connector Name	FUSE BLOCK (J/B)	Connector Name	FUSE BLOCK (J/B)
Connector Type	RS02FBR-DGY	Connector Type	TK03FW-NS10	Connector Type	NS06FW-M2	Connector Type	NS10FW-CS
							
							
Terminal No.	1 2	Terminal No.	28 29	Terminal No.	2A 3A 4A 5A 6A 7A 8A	Terminal No.	4B 5B 6B 7B 8B 9B
Color of Wire	LG B	Color of Wire	B LG	Color of Wire	G G	Color of Wire	P Y
Signal Name [Specification]	EPS SOL+ EPS SOL-	Signal Name [Specification]	- -	Signal Name [Specification]	- - - - - -	Signal Name [Specification]	- - - -

JCGWM0110GB

# RAS CONTROL UNIT

< ECU DIAGNOSIS INFORMATION >

[WITH REAR ACTIVE STEER]

## RAS SYSTEM

Connector No.	M37
Connector Name	STEERING ANGLE SENSOR
Connector Type	TH68FW-NH

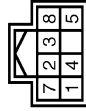

Terminal No.	Color of Wire	Signal Name [Specification]
1	L	CAN-H
2	P	CAN-L

Connector No.	M24
Connector Name	DATA LINK CONNECTOR
Connector Type	BD16FW

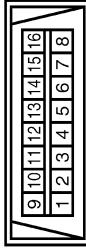

Terminal No.	Color of Wire	Signal Name [Specification]
6	L	-
14	P	-

Connector No.	M7
Connector Name	WIRE TO WIRE
Connector Type	TH80MW-CS (S-TM4)



Terminal No.	Color of Wire	Signal Name [Specification]
38	B	-
40	LG	-
41	G	-
42	P	-
50	B	-
80	L	-
81	P	-
82	L	-
83	P	-

Connector No.	M6
Connector Name	WIRE TO WIRE
Connector Type	TH80MW-CS (S-TM4)



Terminal No.	Color of Wire	Signal Name [Specification]
7	G	-
47	L	-
48	P	-
51	SB	-
52	Y	-
76	V	-

Connector No.	MT16
Connector Name	WIRE TO WIRE
Connector Type	TK38MW-NS10



Terminal No.	Color of Wire	Signal Name [Specification]
28	B	-
29	LG	-

Connector No.	M87
Connector Name	UNIFIED METER AND A/C AMP.
Connector Type	TH32FW-NH



Terminal No.	Color of Wire	Signal Name [Specification]
53	G	IGN
54	Y	BAT
55	B	GND
56	L	CAN-H
71	B	GND
72	P	CAN-L

Connector No.	M66
Connector Name	UNIFIED METER AND A/C AMP.
Connector Type	TH40FW-NH



Terminal No.	Color of Wire	Signal Name [Specification]
7	GR	COMM (AMP->METER)
27	LG	COMM (METER->AMP)

Connector No.	M63
Connector Name	COMBINATION METER
Connector Type	TH40FW-NH



Terminal No.	Color of Wire	Signal Name [Specification]
2	LG	COMM (METER->AMP)
3	GR	COMM (AMP->METER)

JCGWM0111GB

A  
B  
C  
D  
E  
F  
STC  
H  
I  
J  
K  
L  
M  
N  
O  
P

# RAS CONTROL UNIT

< ECU DIAGNOSIS INFORMATION >

[WITH REAR ACTIVE STEER]

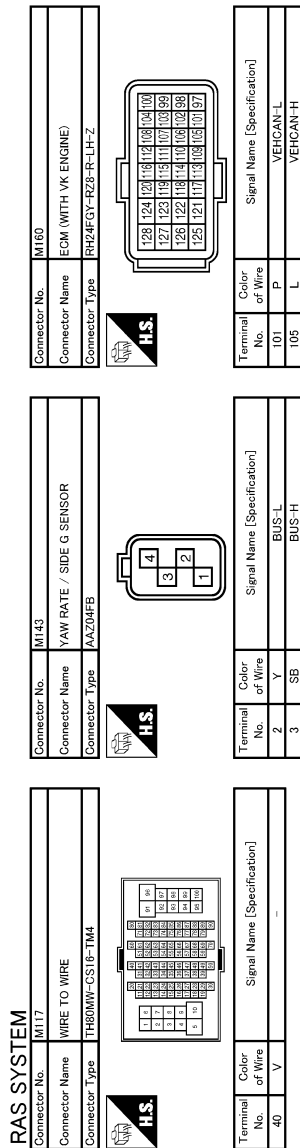

JCGWM0112GB

INFOID:000000003826501

## Fail-Safe

### RAS system

RAS system enters in the fail-safe mode (RAS system stopped) and RAS warning lamp turns ON if an error is detected in RAS system (RAS control unit) component part.



# RAS CONTROL UNIT

< ECU DIAGNOSIS INFORMATION >

[WITH REAR ACTIVE STEER]

Mode	Warn- ing lamp	DTC	Detected area (Error area)	Error area and root cause	A		
Fail-safe	Turn- ON	C1900 C1901 C1905 C1906 C1907 C1908 C1922 C1925 C1927 C1928	RAS control unit	RAS control unit error	B C D		
		Turn- ON	C1902 C1903 C1904 C1910 C1913	RAS motor	RAS motor error	E	
			Turn- ON	C1909	RAS control unit	RAS control unit	F
				Turn- ON	C1911 C1912	RAS motor	RAS motor power supply error
			Turn- ON		C1914	Rear wheel steering sensor	Rear wheel steering sensor power supply error
		Turn- ON		C1915 C1916	Rear wheel steering sensor	Rear wheel steering sensor output voltage error	I
			Turn- OFF	C1917	Rear wheel steering sensor	Rear wheel steering sensor (main and sub) output signal value error signal	J
		Turn- ON		C1918	Rear wheel steering sensor	Rear wheel steering sensor (main and sub) output signal error	K
			Turn- ON	C1919	ABS actuator and electric unit (control unit)	Vehicle speed signal error	L
		Turn- ON		C1920 C1923 C1924	Steering angle sensor	Steering angle sensor input signal error	M
	Turn- ON		C1921	ECM	Engine speed signal error	N	
		Turn- ON	C1926	Steering angle sensor	Steering angle sensor error	O	
	Turn- ON		C1929	ABS actuator and electric unit (control unit)	ABS actuator and electric unit (control unit) error	P	
		Turn- ON	U1000	CAN communication line	CAN communication error		
	Turn- ON		U1010	RAS control unit	RAS control unit		

EPS system

# RAS CONTROL UNIT

## < ECU DIAGNOSIS INFORMATION >

[WITH REAR ACTIVE STEER]

- EPS system (RAS control unit) enters the fail-safe mode (that allows the steering force to be controlled without impairing the drivability) if the input from each sensor is not within the specified range. Then, RAS warning lamp turns ON.

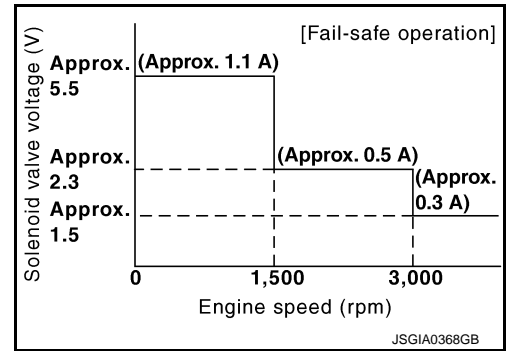

Mode	Warning lamp	DTC	Detected area (Error area)	Error part and root cause
Fail-safe	Turn-ON	C1919	ABS actuator and electronic unit (control unit)	Vehicle speed signal error

## DTC Inspection Priority Chart

INFOID:000000003826502

If some DTCs are displayed at the same time, perform inspections one by one based on the following priority chart.

Priority	Detected items (DTC)
1	<ul style="list-style-type: none"> <li>• U1000 CAN COMM CIRCUIT</li> <li>• U1010 CONTROL UNIT (CAN)</li> </ul>
2	<ul style="list-style-type: none"> <li>• C1900 CONTROL UNIT [ABNORMAL1]</li> <li>• C1901 CONTROL UNIT [ABNORMAL2]</li> <li>• C1905 CONTROL UNIT [ABNORMAL3]</li> <li>• C1906 CONTROL UNIT [ABNORMAL5]</li> <li>• C1907 CONTROL UNIT [ABNORMAL4]</li> <li>• C1908 CONTROL UNIT [ABNORMAL7]</li> <li>• C1909 CONTROL UNIT [ABNORMAL6]</li> <li>• C1922 CONTROL UNIT [ABNORMAL8]</li> <li>• C1925 AD CONVERTER</li> <li>• C1927 CONTROL UNIT [ABNORMAL5]</li> <li>• C1928 CONTROL UNIT [ABNORMAL9]</li> </ul>
3	<ul style="list-style-type: none"> <li>• C1902 MOTOR OUTPUT [REV CURRENT]</li> <li>• C1903 MOTOR OUTPUT [NO CURRENT]</li> <li>• C1904 MOTOR OUTPUT [OVERCURRENT]</li> <li>• C1910 MOTOR OUTPUT [MOTOR LOCK]</li> <li>• C1911 MOTOR VOLTAGE [LOW VOLTAGE]</li> <li>• C1912 MOTOR VOLTAGE [BAD OBSTRCT]</li> <li>• C1913 MOTOR OUTPUT [ABNORML SIG]</li> <li>• C1914 RR ST ANGLE SENSOR [ABNORML VOL]</li> <li>• C1915 RR ST ANGLE SENSOR [MAIN SIGNAL]</li> <li>• C1916 RR ST ANGLE SENSOR [SUB SIGNAL]</li> <li>• C1917 RR ST ANGLE SENSOR [OFFSET SIG1]</li> <li>• C1918 RR ST ANGLE SENSOR [OFFSET SIG2]</li> </ul>
4	<ul style="list-style-type: none"> <li>• C1919 VEHICLE SPEED SEN [NO SIGNAL]</li> <li>• C1920 STEERING ANGLE SEN [NO SIGNAL]</li> <li>• C1921 ENG REV SIGNAL</li> <li>• C1923 STEERING ANGLE SEN [NO CHANGE]</li> <li>• C1924 STEERING ANGLE SEN [NO NEUT STATE]</li> <li>• C1926 STEERING ANGLE SEN</li> <li>• C1929 VDC</li> </ul>

## DTC Index

INFOID:000000003826503

# RAS CONTROL UNIT

< ECU DIAGNOSIS INFORMATION >

[WITH REAR ACTIVE STEER]

DTC	Items (CONSULT screen terms)	Reference	
C1900	CONTROL UNIT [ABNORMAL1]	<a href="#">STC-38, "DTC Logic"</a>	A
C1901	CONTROL UNIT [ABNORMAL2]	<a href="#">STC-38, "DTC Logic"</a>	B
C1902	MOTOR OUTPUT [REV CURRENT]	<a href="#">STC-40, "DTC Logic"</a>	
C1903	MOTOR OUTPUT [NO CURRENT]	<a href="#">STC-40, "DTC Logic"</a>	C
C1904	MOTOR OUTPUT [OVERCURRENT]	<a href="#">STC-40, "DTC Logic"</a>	D
C1905	CONTROL UNIT [ABNORMAL3]	<a href="#">STC-44, "DTC Logic"</a>	
C1906	CONTROL UNIT [ABNORMAL5]	<a href="#">STC-38, "DTC Logic"</a>	E
C1907	CONTROL UNIT [ABNORMAL4]	<a href="#">STC-38, "DTC Logic"</a>	F
C1908	CONTROL UNIT [ABNORMAL7]	<a href="#">STC-44, "DTC Logic"</a>	
C1909	CONTROL UNIT [ABNORMAL6]	<a href="#">STC-46, "DTC Logic"</a>	STC
C1910	MOTOR OUTPUT [MOTOR LOCK]	<a href="#">STC-40, "DTC Logic"</a>	H
C1911	MOTOR VOLTAGE [LOW VOLTAGE]	<a href="#">STC-48, "DTC Logic"</a>	
C1912	MOTOR VOLTAGE [BAD OBSTRCT]	<a href="#">STC-48, "DTC Logic"</a>	I
C1913	MOTOR OUTPUT [ABNORML SIG]	<a href="#">STC-40, "DTC Logic"</a>	J
C1914	RR ST ANGLE SENSOR [ABNORML VOL]	<a href="#">STC-53, "DTC Logic"</a>	
C1915	RR ST ANGLE SENSOR [MAIN SIGNAL]	<a href="#">STC-56, "DTC Logic"</a>	K
C1916	RR ST ANGLE SENSOR [SUB SIGNAL]	<a href="#">STC-56, "DTC Logic"</a>	L
C1917	RR ST ANGLE SENSOR [OFFSET SIG1]	<a href="#">STC-59, "DTC Logic"</a>	
C1918	RR ST ANGLE SENSOR [OFFSET SIG2]	<a href="#">STC-59, "DTC Logic"</a>	M
C1919	VEHICLE SPEED SEN [NO SIGNAL]	<a href="#">STC-62, "DTC Logic"</a>	N
C1920	STEERING ANGLE SEN [NO SIGNAL]	<a href="#">STC-64, "DTC Logic"</a>	
C1921	ENG REV SIGNAL	<a href="#">STC-66, "DTC Logic"</a>	O
C1922	CONTROL UNIT [ABNORMAL8]	<a href="#">STC-44, "DTC Logic"</a>	
C1923	STEERING ANGLE SEN [NO CHANGE]	<a href="#">STC-68, "DTC Logic"</a>	P
C1924	STEERING ANGLE SEN [NO NEUT STATE]	<a href="#">STC-70, "DTC Logic"</a>	
C1925	AD CONVERTER	<a href="#">STC-44, "DTC Logic"</a>	
C1926	STEERING ANGLE SEN	<a href="#">STC-72, "DTC Logic"</a>	

# RAS CONTROL UNIT

< ECU DIAGNOSIS INFORMATION >

[WITH REAR ACTIVE STEER]

DTC	Items (CONSULT screen terms)	Reference
C1927	CONTROL UNIT [ABNORMAL5]	<a href="#">STC-38, "DTC Logic"</a>
C1928	CONTROL UNIT [ABNORMAL9]	<a href="#">STC-44, "DTC Logic"</a>
C1929	VDC	<a href="#">STC-74, "DTC Logic"</a>
U1000	CAN COMM CIRCUIT	<a href="#">STC-76, "DTC Logic"</a>
U1010	CONTROL UNIT (CAN)	<a href="#">STC-77, "DTC Logic"</a>

# RAS WARNING LAMP DOES NOT TURN ON

< SYMPTOM DIAGNOSIS >

[WITH REAR ACTIVE STEER]

## SYMPTOM DIAGNOSIS

### RAS WARNING LAMP DOES NOT TURN ON

#### Description

INFOID:000000003826505

RAS warning lamp does not turn ON when turning ignition switch ON from OFF.

#### Diagnosis Procedure

INFOID:000000003826506

#### 1. CHECK RAS SYSTEM POWER SUPPLY AND GROUND CIRCUIT

##### With CONSULT-III

Perform the trouble diagnosis of the power supply and ground circuit. Refer to [STC-78, "Diagnosis Procedure"](#).

Is the inspection result normal?

YES >> GO TO 2.

NO >> Repair or replace the specific malfunctioning part.

#### 2. CHECK RAS WARNING LAMP

##### With CONSULT-III

Perform the trouble diagnosis of RAS warning lamp. Refer to [STC-84, "Diagnosis Procedure"](#).

Is the inspection result normal?

YES >> Check that there is no malfunction in each harness connector pin terminal or disconnection.

NO >> Repair or replace the specific malfunctioning part.

A  
B  
C  
D  
E  
F  
G  
H  
I  
J  
K  
L  
M  
N  
O  
P

STC

# RAS WARNING LAMP DOSE NOT TURN OFF

< SYMPTOM DIAGNOSIS >

[WITH REAR ACTIVE STEER]

## RAS WARNING LAMP DOSE NOT TURN OFF

### Description

INFOID:000000003826507

RAS system stops (error) when RAS warning lamp turns ON.

### Diagnosis Procedure

INFOID:000000003826508

#### 1.PERFORM SELF-DIAGNOSIS

##### With CONSULT-III

Perform RAS control unit self-diagnosis.

##### Is any DTC detected?

YES >> Repair or replace the specific malfunctioning parts.

NO >> GO TO 2.

#### 2.CHECK RAS WARNING LAMP

##### With CONSULT-III

Perform the trouble diagnosis of RAS warning lamp. Refer to [STC-84. "Diagnosis Procedure"](#).

##### Is the inspection result normal?

YES >> Check that there is no malfunction in each harness connector pin terminal or disconnection.

NO >> Repair or replace the specific malfunctioning part.

# UNBALANCE STEERING WHEEL TURNING FORCE (TORQUE VARIATION)

< SYMPTOM DIAGNOSIS >

[WITH REAR ACTIVE STEER]

## UNBALANCE STEERING WHEEL TURNING FORCE (TORQUE VARIATION)

### Description

INFOID:000000003826513

- The steering force does not change smoothly according to the vehicle speed.
- The steering force is heavy when steering.
- The steering force is light when driving at high speed.

### Diagnosis Procedure

INFOID:000000003826514

#### 1. CHECK RAS SYSTEM VEHICLE SPEED SIGNAL

Perform the trouble diagnosis of the vehicle speed signal. Refer to [STC-62. "Diagnosis Procedure"](#).

Is the inspection result normal?

YES >> GO TO 2.

NO >> Repair or replace the specific malfunctioning part.

#### 2. CHECK STEERING SYSTEM

Check the steering system. Refer to [ST-11. "Inspection"](#) (Power steering fluid), [ST-13. "Inspection"](#) (Steering wheel).

Is the inspection result normal?

YES >> GO TO 3.

NO >> Repair or replace the specific malfunctioning part.

#### 3. CHECK RAS SYSTEM POWER STEERING SOLENOID VALVE

Perform the trouble diagnosis of the power steering solenoid valve. Refer to [STC-82. "Diagnosis Procedure"](#).

Is the inspection result normal?

YES >> Check that there is no malfunction in each harness connector pin terminal or disconnection.

NO >> Repair or replace the specific malfunctioning part.

A  
B  
C  
D  
E  
F  
STC  
H  
I  
J  
K  
L  
M  
N  
O  
P

## PRECAUTION

### PRECAUTIONS

#### Precaution for Supplemental Restraint System (SRS) "AIR BAG" and "SEAT BELT PRE-TENSIONER"

INFOID:000000004167323

The Supplemental Restraint System such as "AIR BAG" and "SEAT BELT PRE-TENSIONER", used along with a front seat belt, helps to reduce the risk or severity of injury to the driver and front passenger for certain types of collision. This system includes seat belt switch inputs and dual stage front air bag modules. The SRS system uses the seat belt switches to determine the front air bag deployment, and may only deploy one front air bag, depending on the severity of a collision and whether the front occupants are belted or unbelted. Information necessary to service the system safely is included in the "SRS AIR BAG" and "SEAT BELT" of this Service Manual.

**WARNING:**

- To avoid rendering the SRS inoperative, which could increase the risk of personal injury or death in the event of a collision which would result in air bag inflation, all maintenance must be performed by an authorized NISSAN/INFINITI dealer.
- Improper maintenance, including incorrect removal and installation of the SRS, can lead to personal injury caused by unintentional activation of the system. For removal of Spiral Cable and Air Bag Module, see the "SRS AIR BAG".
- Do not use electrical test equipment on any circuit related to the SRS unless instructed to in this Service Manual. SRS wiring harnesses can be identified by yellow and/or orange harnesses or harness connectors.

#### PRECAUTIONS WHEN USING POWER TOOLS (AIR OR ELECTRIC) AND HAMMERS

**WARNING:**

- When working near the Air Bag Diagnosis Sensor Unit or other Air Bag System sensors with the ignition ON or engine running, DO NOT use air or electric power tools or strike near the sensor(s) with a hammer. Heavy vibration could activate the sensor(s) and deploy the air bag(s), possibly causing serious injury.
- When using air or electric power tools or hammers, always switch the ignition OFF, disconnect the battery, and wait at least 3 minutes before performing any service.

#### Precaution Necessary for Steering Wheel Rotation after Battery Disconnect

INFOID:000000004167324

**NOTE:**

- Before removing and installing any control units, first turn the push-button ignition switch to the LOCK position, then disconnect both battery cables.
- After finishing work, confirm that all control unit connectors are connected properly, then re-connect both battery cables.
- Always use CONSULT-III to perform self-diagnosis as a part of each function inspection after finishing work. If a DTC is detected, perform trouble diagnosis according to self-diagnosis results.

This vehicle is equipped with a push-button ignition switch and a steering lock unit.

If the battery is disconnected or discharged, the steering wheel will lock and cannot be turned.

If turning the steering wheel is required with the battery disconnected or discharged, follow the procedure below before starting the repair operation.

#### OPERATION PROCEDURE

1. Connect both battery cables.

**NOTE:**

Supply power using jumper cables if battery is discharged.

2. Turn the push-button ignition switch to ACC position.  
(At this time, the steering lock will be released.)
3. Disconnect both battery cables. The steering lock will remain released with both battery cables disconnected and the steering wheel can be turned.
4. Perform the necessary repair operation.



# PRECAUTIONS

< PRECAUTION >

[WITH REAR ACTIVE STEER]

5. When the repair work is completed, re-connect both battery cables. With the brake pedal released, turn the push-button ignition switch from ACC position to ON position, then to LOCK position. (The steering wheel will lock when the push-button ignition switch is turned to LOCK position.)
6. Perform self-diagnosis check of all control units using CONSULT-III.

A  
B  
C  
D  
E  
F  
H  
I  
J  
K  
L  
M  
N  
O  
P

**STC**

## REMOVAL AND INSTALLATION

### RAS CONTROL UNIT

#### Exploded View

INFOID:000000003844333

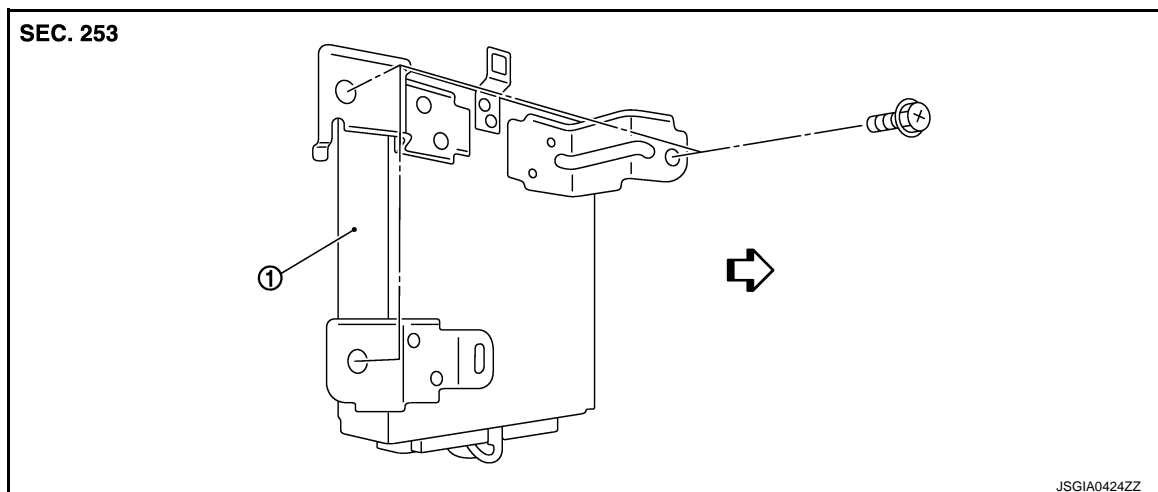

1. RAS control unit

↶:Vehicle front

### Removal and Installation

INFOID:000000003840724

#### REMOVAL

1. Turn the ignition switch OFF.
2. Remove the luggage side finisher lower (LH). Refer to [INT-28, "Exploded View"](#).
3. Remove E-SUS control unit. Refer to [SCS-59, "Exploded View"](#).
4. Disconnect the RAS control unit connector and harness clip.
5. Remove the RAS control unit mounting bolts.
6. Remove the RAS control unit.

#### INSTALLATION

Install in the reverse order of removal.

# REAR ACTIVE STEER

< REMOVAL AND INSTALLATION >

[WITH REAR ACTIVE STEER]

## REAR ACTIVE STEER

Exploded View

INFOID:000000003844334

COMPONENTS

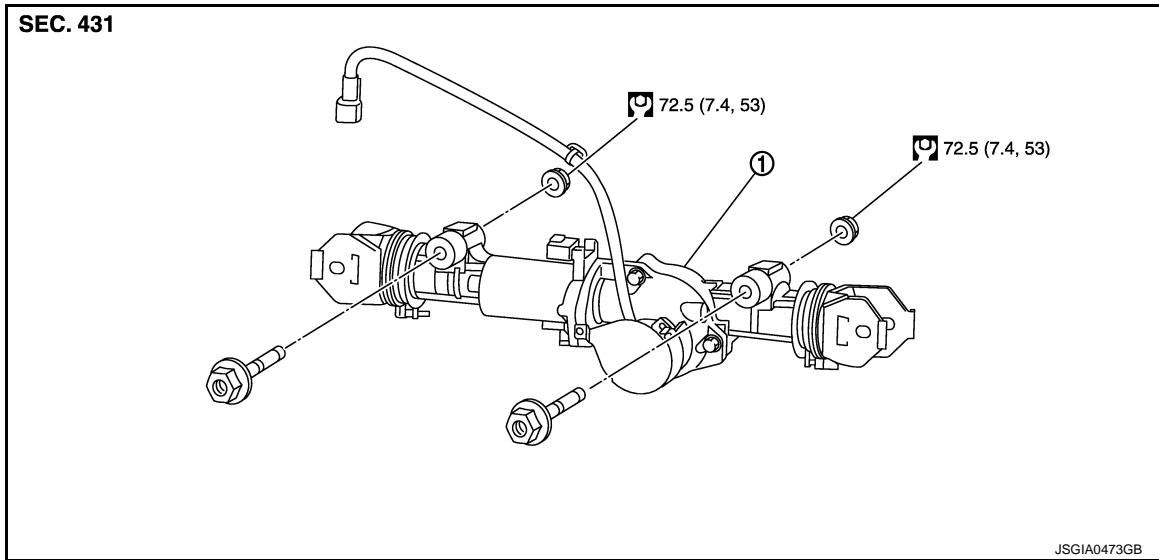

1. RAS actuator assembly

Refer to [GI-4. "Components"](#), for the symbols in the figure.

## Removal and Installation

INFOID:000000003844340

### REMOVAL

1. Remove coil spring and rear lower link. Refer to [RSU-8. "Exploded View"](#).
2. Disconnect harness connector from RAS actuator assembly and rear suspension member.
3. Remove fixing bolts and nuts of RAS actuator assembly, and then remove RAS actuator assembly from rear suspension member.

### INSTALLATION

Note the following, and install in the reverse order of removal.

- When installing RAS actuator assembly to rear suspension member, check the mounting surfaces of RAS actuator assembly and rear suspension member for oil, dirt, sand, or other foreign materials.
- Check rear wheel alignment. Refer to [RSU-6. "Inspection"](#).