

**SECTION MA**  
**MAINTENANCE**

A  
B  
C  
D  
E  
F  
G  
H  
I  
J  
K  
L  
M  
N  
O

**CONTENTS**

<b>PREPARATION</b> .....	<b>ENGINE OIL : Refilling</b> .....	4	18
<b>PREPARATION</b> .....	<b>OIL FILTER</b> .....	4	19
Special Service Tool .....	OIL FILTER : Removal and Installation .....	4	19
Commercial Service Tool .....	OIL FILTER : Inspection .....	4	20
<b>PERIODIC MAINTENANCE</b> .....	<b>SPARK PLUG</b> .....	5	20
<b>GENERAL MAINTENANCE</b> .....	SPARK PLUG : Removal and Installation .....	5	20
Explanation of General Maintenance .....	SPARK PLUG : Inspection .....	5	21
<b>PERIODIC MAINTENANCE</b> .....	<b>EVAP VAPOR LINES</b> .....	7	21
Introduction of Periodic Maintenance .....	EVAP VAPOR LINES : Inspection .....	7	21
Schedule 1 .....	<b>ENGINE MAINTENANCE (VK50VE)</b> .....	7	22
Schedule 2 .....	<b>DRIVE BELTS</b> .....	9	22
<b>RECOMMENDED FLUIDS AND LUBRICANTS</b> .....	DRIVE BELTS : Exploded View .....	12	22
Fluids and Lubricants .....	DRIVE BELTS : Checking .....	12	22
Engine Oil Recommendation .....	DRIVE BELTS : Tension Adjustment .....	13	23
Anti-Freeze Coolant Mixture Ratio .....	<b>ENGINE COOLANT</b> .....	13	23
<b>ENGINE MAINTENANCE (VQ35HR)</b> .....	ENGINE COOLANT : Draining .....	14	23
<b>DRIVE BELT</b> .....	ENGINE COOLANT : Refilling .....	14	23
DRIVE BELT : Exploded View .....	ENGINE COOLANT : Flushing .....	14	25
DRIVE BELT : Checking .....	<b>FUEL LINES</b> .....	14	25
DRIVE BELT : Tension Adjustment .....	FUEL LINES : Inspection .....	14	26
<b>ENGINE COOLANT</b> .....	<b>AIR CLEANER FILTER</b> .....	14	26
ENGINE COOLANT : Draining .....	AIR CLEANER FILTER : Removal and Installation .....	14	26
ENGINE COOLANT : Refilling .....	<b>ENGINE OIL</b> .....	15	26
ENGINE COOLANT : Flushing .....	ENGINE OIL : Draining .....	16	26
<b>FUEL LINES</b> .....	ENGINE OIL : Refilling .....	17	27
FUEL LINES : Inspection .....	<b>OIL FILTER</b> .....	17	27
<b>AIR CLEANER FILTER</b> .....	OIL FILTER : Removal and Installation .....	17	27
AIR CLEANER FILTER : Removal and Installation .....	OIL FILTER : Inspection .....	18	28
<b>ENGINE OIL</b> .....	<b>SPARK PLUG</b> .....	18	28
ENGINE OIL : Draining .....	SPARK PLUG : Removal and Installation .....	18	28
ENGINE OIL : Refilling .....	SPARK PLUG : Inspection .....	18	28

<b>EVAP VAPOR LINES</b> .....	<b>29</b>	<b>BRAKE FLUID</b> .....	<b>38</b>
EVAP VAPOR LINES : Inspection .....	29	BRAKE FLUID : Changing .....	39
<b>CHASSIS MAINTENANCE</b> .....	<b>30</b>	<b>DISC BRAKE</b> .....	<b>39</b>
<b>EXHAUST SYSTEM</b> .....	<b>30</b>	DISC BRAKE : Inspection .....	39
EXHAUST SYSTEM : Inspection .....	30	DISC BRAKE : Front Disc Brake .....	39
<b>TRANSFER FLUID</b> .....	<b>30</b>	DISC BRAKE : Rear Disc Brake .....	40
TRANSFER FLUID : Inspection .....	30	<b>STEERING GEAR AND LINKAGE</b> .....	<b>40</b>
TRANSFER FLUID : Draining .....	30	STEERING GEAR AND LINKAGE : Inspection .....	40
TRANSFER FLUID : Refilling .....	31	<b>POWER STEERING FLUID AND LINES</b> .....	<b>40</b>
<b>FRONT PROPELLER SHAFT: 2S56A</b> .....	<b>31</b>	POWER STEERING FLUID AND LINES : Inspection .....	41
FRONT PROPELLER SHAFT: 2S56A : Inspection .....	31	<b>AXLE AND SUSPENSION PARTS</b> .....	<b>41</b>
<b>REAR PROPELLER SHAFT: 3S80A-R</b> .....	<b>31</b>	AXLE AND SUSPENSION PARTS : Inspection .....	41
REAR PROPELLER SHAFT: 3S80A-R : Inspection .....	31	<b>DRIVE SHAFT</b> .....	<b>41</b>
<b>REAR PROPELLER SHAFT: 3F80A-1VL107</b> .....	<b>32</b>	DRIVE SHAFT : Inspection .....	42
REAR PROPELLER SHAFT: 3F80A-1VL107 : Inspection .....	32	<b>BODY MAINTENANCE</b> .....	<b>43</b>
<b>REAR PROPELLER SHAFT: 3F-R-2VL107</b> .....	<b>33</b>	<b>LOCKS, HINGES AND HOOD LATCH</b> .....	<b>43</b>
REAR PROPELLER SHAFT: 3F-R-2VL107 : Inspection .....	33	LOCKS, HINGES AND HOOD LATCH : Lubricating .....	43
<b>FRONT DIFFERENTIAL GEAR OIL: F160A</b> .....	<b>33</b>	<b>SEAT BELT, BUCKLES, RETRACTORS, ANCHORS AND ADJUSTERS</b> .....	<b>43</b>
FRONT DIFFERENTIAL GEAR OIL: F160A : Inspection .....	33	SEAT BELT, BUCKLES, RETRACTORS, ANCHORS AND ADJUSTERS : Inspection .....	43
FRONT DIFFERENTIAL GEAR OIL: F160A : Draining .....	34	<b>SERVICE DATA AND SPECIFICATIONS (SDS)</b> .....	<b>44</b>
FRONT DIFFERENTIAL GEAR OIL: F160A : Refilling .....	34	<b>SERVICE DATA AND SPECIFICATIONS (SDS)</b> .....	<b>44</b>
<b>REAR DIFFERENTIAL GEAR OIL: R200</b> .....	<b>34</b>	<b>DRIVE BELT (VQ35HR)</b> .....	<b>44</b>
REAR DIFFERENTIAL GEAR OIL: R200 : Inspection .....	34	DRIVE BELT (VQ35HR) : Drive Belt .....	44
REAR DIFFERENTIAL GEAR OIL: R200 : Draining .....	35	<b>DRIVE BELTS (VK50VE)</b> .....	<b>44</b>
REAR DIFFERENTIAL GEAR OIL: R200 : Refilling .....	35	DRIVE BELTS (VK50VE) : Drive Belts .....	44
<b>REAR DIFFERENTIAL GEAR OIL: R230</b> .....	<b>35</b>	<b>ENGINE COOLANT (VQ35HR)</b> .....	<b>44</b>
REAR DIFFERENTIAL GEAR OIL: R230 : Inspection .....	35	ENGINE COOLANT (VQ35HR) : Periodical Maintenance Specification .....	44
REAR DIFFERENTIAL GEAR OIL: R230 : Draining .....	36	<b>ENGINE COOLANT (VK50VE)</b> .....	<b>44</b>
REAR DIFFERENTIAL GEAR OIL: R230 : Refilling .....	36	ENGINE COOLANT (VK50VE) : Periodical Maintenance Specification .....	44
<b>WHEELS (BONDING WEIGHT TYPE)</b> .....	<b>36</b>	<b>ENGINE OIL (VQ35HR)</b> .....	<b>44</b>
WHEELS (BONDING WEIGHT TYPE) : Adjustment .....	36	ENGINE OIL (VQ35HR) : Periodical Maintenance Specification .....	44
<b>BRAKE FLUID LEVEL AND LEAKS</b> .....	<b>38</b>	<b>ENGINE OIL (VK50VE)</b> .....	<b>44</b>
BRAKE FLUID LEVEL AND LEAKS : Inspection .....	38	ENGINE OIL (VK50VE) : Periodical Maintenance Specification .....	44
<b>BRAKE LINES AND CABLES</b> .....	<b>38</b>	<b>SPARK PLUG (VQ35HR)</b> .....	<b>45</b>
BRAKE LINES AND CABLES : Inspection .....	38	SPARK PLUG (VQ35HR) : Spark Plug .....	45
		<b>SPARK PLUG (VK50VE)</b> .....	<b>45</b>

---

SPARK PLUG (VK50VE) : Spark Plug .....45

**ROAD WHEEL** .....**45**

ROAD WHEEL : Road Wheel .....45

A

B

C

D

E

F

G

H

I

J

K

L

M

N

O

MA

# PREPARATION

< PREPARATION >

## PREPARATION

### PREPARATION

#### Special Service Tool

INFOID:000000004001291

The actual shapes of Kent-Moore tools may differ from those of special service tools illustrated here.

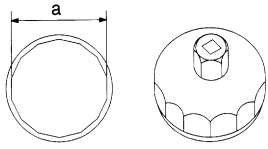
Tool number (Kent-Moore No.) Tool name	Description
KV10115801 (J38956) Oil filter wrench <div style="text-align: center;">  <p>S-NT375</p> </div>	Removing and installing oil filter <b>a: 64.3 mm (2.531 in)</b>

#### Commercial Service Tool

INFOID:000000004001292

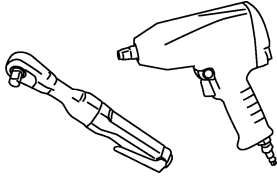
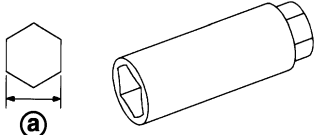
Tool name (Kent-Moore No.)	Description
Power tool ( — ) <div style="text-align: center;">  <p>PBIC0190E</p> </div>	Loosening nuts and bolts
Spark plug wrench ( — ) <div style="text-align: center;">  <p>JPBIA0399ZZ</p> </div>	Removing and installing spark plug a : 14 mm (0.55 in)

# GENERAL MAINTENANCE

< PERIODIC MAINTENANCE >

## PERIODIC MAINTENANCE

### GENERAL MAINTENANCE

#### Explanation of General Maintenance

INFOID:000000004001293

General maintenance includes those items which should be checked during the normal day-to-day operation of the vehicle. They are essential if the vehicle is to continue operating properly. The owners can perform checks and inspections themselves or have their INFINITI dealers do them.

#### OUTSIDE THE VEHICLE

The maintenance items listed here should be performed from time to time, unless otherwise specified.

Item		Reference page
<b>Tires</b>	Check the pressure with a gauge often and always prior to long distance trips. Adjust the pressure in all tires, including the spare, to the pressure specified. Check carefully for damage, cuts or excessive wear.	<a href="#">WT-76</a>
<b>Wheel nuts</b>	When checking the tires, make sure no nuts are missing, and check for any loose nuts. Tighten if necessary.	—
<b>Tire rotation</b>	Tires should be rotated every 12,000km (7,500 miles).	<a href="#">MA-36</a>
<b>Tire Pressure Monitoring System (TPMS) transmitter components</b>	Replace the TPMS transmitter grommet seal, valve core and cap when the tires are replaced due to wear or age.	<a href="#">WT-73</a>
<b>Wheel alignment and balance</b>	If the vehicle should pull to either side while driving on a straight and level road, or if you detect uneven or abnormal tire wear, there may be a need for wheel alignment. If the steering wheel or seat vibrates at normal highway speeds, wheel balancing may be needed.	<a href="#">FSU-8</a> (2WD) <a href="#">FSU-26</a> (AWD) <a href="#">RSU-6</a> <a href="#">MA-36</a>
<b>Windshield</b>	Clean the windshield on a regular basis. Check the windshield at least every six months for cracks or other damage. Repair as necessary.	—
<b>Windshield wiper blades</b>	Check for cracks or wear if they do not wipe properly.	—
<b>Doors and engine hood</b>	Check that all doors and the engine hood operate smoothly as well as the back door, trunk lid and glass hatch. Also make sure that all latches lock securely. Lubricate if necessary. Make sure that the secondary latch keeps the hood from opening when the primary latch is released. When driving in areas using road salt or other corrosive materials, check lubrication frequently.	<a href="#">MA-43</a>
<b>Lamps</b>	Make sure that the headlamps, stop lamps, tail lamps, turn signal lamps, and other lamps are all operating properly and installed securely. Also check headlamp aim. Clean the headlamps on a regular basis.	—

#### INSIDE THE VEHICLE

The maintenance items listed here should be checked on a regular basis, such as when performing periodic maintenance, cleaning the vehicle, etc.

Item		Reference page
<b>Warning lamps and chimes</b>	Make sure that all warning lamps and chimes are operating properly.	—
<b>Windshield wiper and washer</b>	Check that the wipers and washer operate properly and that the wipers do not streak.	—
<b>Windshield defroster</b>	Check that the air comes out of the defroster outlets properly and in sufficient quantity when operating the heater or air conditioner.	—
<b>Steering wheel</b>	Check that it has the specified play. Check for changes in the steering condition, such as excessive play, hard steering or strange noises. <b>Free play: Less than 35 mm (1.38 in)</b>	—
<b>Seats</b>	Check seat position controls such as seat adjusters, seatback recliner, etc. to make sure they operate smoothly and that all latches lock securely in every position. Check that the head restraints move up and down smoothly and that the locks (if equipped) hold securely in all latched positions. Check that the latches lock securely for folding-down rear seatbacks.	—

# GENERAL MAINTENANCE

## < PERIODIC MAINTENANCE >

Item		Reference page
<b>Seat belts</b>	Check that all parts of the seat belt system (e.g. buckles, anchors, adjusters and retractors) operate properly and smoothly, and are installed securely. Check the belt webbing for cuts, fraying, wear or damage.	<a href="#">MA-43</a>
<b>Accelerator pedal</b>	Check the pedal for smooth operation and make sure the pedal does not catch or require uneven effort. Keep the floor mats away from the pedal.	—
<b>Brakes</b>	Check that the brake does not pull the vehicle to one side when applied.	—
<b>Brake pedal and booster</b>	Check the pedal for smooth operation and make sure it has the proper distance under it when depressed fully. Check the brake booster function. Be sure to keep the floor mats away from the pedal.	<a href="#">BR-7</a> <a href="#">BR-13</a>
<b>Parking brake</b>	Check that the pedal has the proper travel and make sure that the vehicle is held securely on a fairly steep hill when only the parking brake is applied.	<a href="#">PB-3</a>
<b>Automatic transmission "Park" mechanism</b>	Check that the lock release button on the selector lever operates properly and smoothly. On a fairly steep hill check that the vehicle is held securely with the selector lever in the P (Park) position without applying any brakes.	—

## UNDER THE HOOD AND VEHICLE

The maintenance items listed here should be checked periodically (e.g. each time you check the engine oil or refuel).

Item		Reference page
<b>Windshield washer fluid</b>	Check that there is adequate fluid in the tank.	—
<b>Engine coolant level</b>	Check the coolant level when the engine is cold.	<a href="#">CO-8</a> <a href="#">CO-33</a>
<b>Radiator and hoses</b>	Check the front of the radiator and clean off any dirt, insects, leaves, etc., that may have accumulated. Make sure the hoses have no cracks, deformation, deterioration or loose connections.	—
<b>Brake fluid level</b>	Make sure that the brake and clutch fluid level is between the "MAX" and "MIN" lines on the reservoir.	<a href="#">MA-38</a>
<b>Battery</b>	Check the fluid level in each cell. It should be between the "MAX" and "MIN" lines. Vehicles operated in high temperatures or under severe conditions require frequent checks of the battery fluid level.	<a href="#">PG-3</a>
<b>Engine drive belts</b>	Make sure that no belt is frayed, worn, cracked or oily.	<a href="#">MA-14</a> <a href="#">MA-22</a>
<b>Engine oil level</b>	Check the level on the oil level gauge after parking the vehicle on a level spot and turning off the engine.	<a href="#">LU-6</a> <a href="#">LU-25</a>
<b>Power steering fluid level and lines</b>	Check the level on the dipstick with the engine off. Check the lines for improper attachment, leaks, cracks, etc.	<a href="#">MA-41</a>
<b>Exhaust system</b>	Make sure there are no loose supports, cracks or holes. If the sound of the exhaust seems unusual or there is a smell of exhaust fumes, immediately locate the trouble and correct it.	<a href="#">MA-30</a>
<b>Underbody</b>	The underbody is frequently exposed to corrosive substances such as those used on icy roads or to control dust. It is very important to remove these substances, otherwise rust will form on the floor pan, frame, fuel lines and around the exhaust system. At the end of winter, the underbody should be thoroughly flushed with plain water, being careful to clean those areas where mud and dirt can easily accumulate.	—
<b>Fluid leaks</b>	Check under the vehicle for fuel, oil, water or other fluid leaks after the vehicle has been parked for a while. Water dripping from the air conditioner after use is normal. If you should notice any leaks or gasoline fumes are evident, check for the cause and correct it immediately.	—

# PERIODIC MAINTENANCE

< PERIODIC MAINTENANCE >

## PERIODIC MAINTENANCE

### Introduction of Periodic Maintenance

INFOID:000000004001294

Two different maintenance schedules are provided, and should be used, depending upon the conditions in which the vehicle is mainly operated. **After 60,000 miles (96,000 km) or 48 months, continue the periodic maintenance at the same mileage/time intervals.**

Schedule 1	Follow Periodic Maintenance Schedule 1 if the driving habits frequently include one or more of the following driving conditions: <ul style="list-style-type: none"> <li>• Repeated short trips of less than 5 miles (8 km).</li> <li>• Repeated short trips of less than 10 miles (16 km) with outside temperatures remaining below freezing.</li> <li>• Operating in hot weather in stop-and-go "rush hour" traffic.</li> <li>• Extensive idling and/or low speed driving for long distances, such as police, taxi or door-to-door delivery use.</li> <li>• Driving in dusty conditions.</li> <li>• Driving on rough, muddy, or salt spread roads.</li> <li>• Towing a trailer, using a camper or a car-top carrier.</li> </ul>	Emission Control System Maintenance	<a href="#">MA-7</a>
		Chassis and Body Maintenance	
Schedule 2	Follow Periodic Maintenance Schedule 2 if none of driving conditions shown in Schedule 1 apply to the driving habits.	Emission Control System Maintenance	<a href="#">MA-9</a>
		Chassis and Body Maintenance	

### Schedule 1

INFOID:000000004001295

### EMISSION CONTROL SYSTEM

Abbreviations: R = Replace. I = Inspect. Correct or replace if necessary. [ ]: At the mileage intervals only

MAINTENANCE OPERATION		MAINTENANCE INTERVAL								Reference Section - Page or - Content Title
Perform at number of miles, kilometers or months, whichever comes first.	Miles x 1,000 (km x 1,000) Months	3.75 (6) 3	7.50 (12) 6	11.25 (18) 9	15 (24) 12	18.75 (30) 15	22.5 (36) 18	26.25 (42) 21	30 (48) 24	
Drive belts	NOTE (1)									<a href="#">MA-14</a> <a href="#">MA-22</a>
Air cleaner filter	NOTE (2)								[R]	<a href="#">MA-18</a> <a href="#">MA-26</a>
EVAP vapor lines									I*	<a href="#">MA-21</a> <a href="#">MA-29</a>
Fuel lines									I*	<a href="#">MA-17</a> <a href="#">MA-26</a>
Fuel filter	NOTE (3)									—
Engine coolant	NOTE (4)									<a href="#">MA-14</a> <a href="#">MA-23</a>
Engine oil		R	R	R	R	R	R	R	R	<a href="#">MA-18</a> <a href="#">MA-26</a>
Engine oil filter (Use genuine NISSAN engine oil filter or equivalent.)		R	R	R	R	R	R	R	R	<a href="#">MA-19</a> <a href="#">MA-27</a>
Spark plugs (Iridium-tipped type)	NOTE (5)	Replace every 105,000 miles (169,000 km).								<a href="#">MA-20</a> <a href="#">MA-28</a>
Intake & exhaust valve clearance*	NOTE (6)									<a href="#">EM-20</a> <a href="#">EM-169</a>

A  
B  
C  
D  
E  
F  
G  
H  
I  
J  
K  
L  
M  
N  
O  
MA

# PERIODIC MAINTENANCE

< PERIODIC MAINTENANCE >

MAINTENANCE OPERATION		MAINTENANCE INTERVAL								Reference Section - Page or - Content Title
Perform at number of miles, kilometers or months, whichever comes first.	Miles x 1,000 (km x 1,000) Months	33.75 (54) 27	37.5 (60) 30	41.25 (66) 33	45 (72) 36	48.75 (78) 39	52.5 (84) 42	56.25 (90) 45	60 (96) 48	
Drive belts	NOTE (1)								I*	<a href="#">MA-14</a> <a href="#">MA-22</a>
Air cleaner filter	NOTE (2)								[R]	<a href="#">MA-18</a> <a href="#">MA-26</a>
EVAP vapor lines									I*	<a href="#">MA-21</a> <a href="#">MA-29</a>
Fuel lines									I*	<a href="#">MA-17</a> <a href="#">MA-26</a>
Fuel filter	NOTE (3)									—
Engine coolant	NOTE (4)								R*	<a href="#">MA-14</a> <a href="#">MA-23</a>
Engine oil		R	R	R	R	R	R	R	R	<a href="#">MA-18</a> <a href="#">MA-26</a>
Engine oil filter (Use genuine NISSAN engine oil filter or equivalent.)		R	R	R	R	R	R	R	R	<a href="#">MA-19</a> <a href="#">MA-27</a>
Spark plugs (Iridium-tipped type)	NOTE (5)	Replace every 105,000 miles (169,000 km).								<a href="#">MA-20</a> <a href="#">MA-28</a>
Intake & exhaust valve clearance*	NOTE (6)									<a href="#">EM-20</a> <a href="#">EM-169</a>

**NOTE:**

- (1) After 60,000 miles (96,000 km) or 48 months, inspect every 15,000 miles (24,000 km) or 12 months. Replace the drive belts if found damaged or if the auto belt tensioner reading reaches the maximum limit.
- (2) If operating mainly in dusty conditions, more frequent maintenance may be required.
- (3) Maintenance-free item. For service procedures, refer to FL section.
- (4) After 60,000 miles (96,000 km) or 48 months, replace every 30,000 miles (48,000 km) or 24 months.
- (5) Replace spark plug when the spark plug gap exceeds 1.4 mm (0.055 in) even if within specified periodic replacement mileage.
- (6) Periodic maintenance is not required. However, if valve noise increases, inspect valve clearance.

\* Maintenance items and intervals with "\*" are recommended by INFINITI for reliable vehicle operation. The owner need not perform such maintenance in order to maintain the emission warranty or manufacturer recall liability. Other maintenance items and intervals are required.

## CHASSIS AND BODY

Abbreviations: R = Replace. I = Inspect. Correct or replace if necessary.

MAINTENANCE OPERATION		MAINTENANCE INTERVAL								Reference Section - Page or - Content Title
Perform at number of miles, kilometers or months, whichever comes first.	Miles x 1,000 (km x 1,000) Months	3.75 (6) 3	7.50 (12) 6	11.25 (18) 9	15 (24) 12	18.75 (30) 15	22.5 (36) 18	26.25 (42) 21	30 (48) 24	
Brake lines & cables					I				I	<a href="#">MA-38</a>
Brake pads & rotors			I		I		I		I	<a href="#">MA-39</a>
Automatic transmission fluid&	NOTE (1)									—
Transfer fluid & differential gear oil	NOTE (2)				I				I	<a href="#">MA-30</a> <a href="#">MA-33</a> <a href="#">MA-34</a> <a href="#">MA-35</a>
Steering gear & linkage, axle & suspension parts			I		I		I		I	<a href="#">MA-40</a> <a href="#">MA-41</a>
Tire rotation	NOTE (3)									<a href="#">MA-5</a> <a href="#">MA-36</a>



# PERIODIC MAINTENANCE

## < PERIODIC MAINTENANCE >

MAINTENANCE OPERATION		MAINTENANCE INTERVAL								Reference Section - Page or - Content Title
Perform at number of miles, kilometers or months, whichever comes first.	Miles x 1,000 (km x 1,000) Months	3.75 (6) 3	7.50 (12) 6	11.25 (18) 9	15 (24) 12	18.75 (30) 15	22.5 (36) 18	26.25 (42) 21	30 (48) 24	
Propeller shaft and drive shaft boots (AWD models)			I		I		I		I	<a href="#">MA-31</a> <a href="#">MA-31</a> <a href="#">MA-32</a> <a href="#">MA-33</a> <a href="#">MA-42</a>
Exhaust system			I		I		I		I	<a href="#">MA-30</a>
In-cabin microfilter					R				R	<a href="#">VTL-9</a>
Climate controlled seat filter									R	<a href="#">SE-96</a>

MAINTENANCE OPERATION		MAINTENANCE INTERVAL								Reference Section - Page or - Content Title
Perform at number of miles, kilometers or months, whichever comes first.	Miles x 1,000 (km x 1,000) Months	33.75 (54) 27	37.5 (60) 30	41.25 (66) 33	45 (72) 36	48.75 (78) 39	52.5 (84) 42	56.25 (90) 45	60 (96) 48	
Brake lines & cables					I				I	<a href="#">MA-38</a>
Brake pads & rotors			I		I		I		I	<a href="#">MA-39</a>
Automatic transmission fluid	NOTE (1)									-
Transfer fluid & differential gear oil	NOTE (2)				I				I	<a href="#">MA-30</a> <a href="#">MA-33</a> <a href="#">MA-34</a> <a href="#">MA-35</a>
Steering gear & linkage, axle & suspension parts			I		I		I		I	<a href="#">MA-40</a> <a href="#">MA-41</a>
Tire rotation	NOTE (3)									<a href="#">MA-5</a> <a href="#">MA-36</a>
Propeller shaft and drive shaft boots (AWD models)			I		I		I		I	<a href="#">MA-31</a> <a href="#">MA-31</a> <a href="#">MA-32</a> <a href="#">MA-33</a> <a href="#">MA-42</a>
Exhaust system			I		I		I		I	<a href="#">MA-30</a>
In-cabin microfilter					R				R	<a href="#">VTL-9</a>
Climate controlled seat filter									R	<a href="#">SE-96</a>

**NOTE:**

- (1) Automatic transmission fluid is maintenance-free.
- (2) If towing a trailer, using a camper or a car-top carrier, or driving on rough or muddy roads, change (not just inspect) fluid /oil at every 30,000 miles (48,000 km) or 24 months.
- (3) Refer to "Tire rotation" under the "General maintenance" heading earlier in this section.

## Schedule 2

INFOID:000000004001296

## EMISSION CONTROL SYSTEM

MA

# PERIODIC MAINTENANCE

## < PERIODIC MAINTENANCE >

Abbreviations: R = Replace. I = Inspect. Correct or replace if necessary. [ ]: At the mileage intervals only

MAINTENANCE OPERATION		MAINTENANCE INTERVAL								Reference Section - Page or - Content Title
Perform at number of miles, kilometers or months, whichever comes first.	Miles x 1,000 (km x 1,000) Months	7.5 (12) 6	15 (24) 12	22.5 (36) 18	30 (48) 24	37.5 (60) 30	45 (72) 36	52.5 (84) 42	60 (96) 48	
Drive belts	NOTE (1)								I*	<a href="#">MA-14</a> <a href="#">MA-22</a>
Air cleaner filter					[R]				[R]	<a href="#">MA-18</a> <a href="#">MA-26</a>
EVAP vapor lines					I*				I*	<a href="#">MA-21</a> <a href="#">MA-29</a>
Fuel lines					I*				I*	<a href="#">MA-17</a> <a href="#">MA-26</a>
Fuel filter	NOTE (2)									—
Engine coolant	NOTE (3)								R*	<a href="#">MA-14</a> <a href="#">MA-23</a>
Engine oil		R	R	R	R	R	R	R	R	<a href="#">MA-18</a> <a href="#">MA-26</a>
Engine oil filter (Use genuine NISSAN engine oil filter or equivalent.)		R	R	R	R	R	R	R	R	<a href="#">MA-19</a> <a href="#">MA-27</a>
Spark plugs (Iridium-tipped type)	NOTE (4)	Replace every 105,000 miles (169,000 km).								<a href="#">MA-20</a> <a href="#">MA-28</a>
Intake & exhaust valve clearance*	NOTE (5)									<a href="#">EM-20</a> <a href="#">EM-169</a>

**NOTE:**

- (1) After 60,000 miles (96,000 km) or 48 months, inspect every 15,000 miles (24,000 km) or 12 months. Replace the drive belts if found damaged or if the auto belt tensioner reading reaches the maximum limit.
- (2) Maintenance-free item. For service procedures, refer to FL section.
- (3) After 60,000 miles (96,000 km) or 48 months, replace every 30,000 miles (48,000 km) or 24 months.
- (4) Replace spark plug when the spark plug gap exceeds 1.4 mm (0.055 in) even if within specified periodic replacement mileage.
- (5) Periodic maintenance is not required. However, if valve noise increases, inspect valve clearance.

\* Maintenance items and intervals with "\*" are recommended by INFINITI for reliable vehicle operation. The owner need not perform such maintenance in order to maintain the emission warranty or manufacturer recall liability. Other maintenance items and intervals are required.

## CHASSIS AND BODY

Abbreviations: R = Replace. I = Inspect. Correct or replace if necessary.

MAINTENANCE OPERATION		MAINTENANCE INTERVAL								Reference Section - Page or - Content Title
Perform at number of miles, kilometers or months, whichever comes first.	Miles x 1,000 (km x 1,000) Months	7.5 (12) 6	15 (24) 12	22.5 (36) 18	30 (48) 24	37.5 (60) 30	45 (72) 36	52.5 (84) 42	60 (96) 48	
Brake lines & cables			I		I		I		I	<a href="#">MA-38</a>
Brake pads & rotors			I		I		I		I	<a href="#">MA-39</a>
Automatic transmission fluid	NOTE (1)									—
Transfer fluid & differential gear oil			I		I		I		I	<a href="#">MA-30</a> <a href="#">MA-33</a> <a href="#">MA-34</a> <a href="#">MA-35</a>
Steering gear & linkage, axle & suspension parts					I				I	<a href="#">MA-40</a> <a href="#">MA-41</a>
Tire rotation	NOTE (2)									<a href="#">MA-5</a> <a href="#">MA-36</a>

# PERIODIC MAINTENANCE

## < PERIODIC MAINTENANCE >

MAINTENANCE OPERATION		MAINTENANCE INTERVAL								Reference Section - Page or - Content Title
Perform at number of miles, kilometers or months, whichever comes first.	Miles x 1,000 (km x 1,000) Months	7.5 (12)	15 (24)	22.5 (36)	30 (48)	37.5 (60)	45 (72)	52.5 (84)	60 (96)	
Propeller shaft and drive shaft boots (AWD models)			I		I		I		I	<a href="#">MA-31</a> <a href="#">MA-31</a> <a href="#">MA-32</a> <a href="#">MA-33</a> <a href="#">MA-42</a>
Exhaust system					I				I	<a href="#">MA-30</a>
In-cabin microfilter			R		R		R		R	<a href="#">VTL-9</a>
Climate controlled seat filter					R				R	<a href="#">SE-96</a>

**NOTE:**

- (1) Automatic transmission fluid is maintenance-free item.
- (2) Refer to "Tire rotation" under the "General maintenance" heading earlier in this section.

A  
B  
C  
D  
E  
F  
G  
H  
I  
J  
K  
L  
M  
N  
O

MA

# RECOMMENDED FLUIDS AND LUBRICANTS

< PERIODIC MAINTENANCE >

## RECOMMENDED FLUIDS AND LUBRICANTS

### Fluids and Lubricants

INFOID:000000004001297

			Capacity (Approximate)			Recommended Fluids/Lubricants
			US mea- sure	Imp mea- sure	Liter	
Engine oil Drain and refill	With oil filter change	VQ35HR	5-1/8 qt	4-1/4 qt	4.9	<ul style="list-style-type: none"> <li>• Engine oil with API Certification Mark*<sup>1</sup></li> <li>• Viscosity SAE 5W-30</li> </ul>
		VK50VE	7-1/8 qt	5-7/8 qt	6.7	
	Without oil filter change	VQ35HR	4-7/8 qt	4 qt	4.6	
		VK50VE	6-1/8 qt	5-1/8 qt	5.8	
Dry engine (Overhaul)		VQ35HR	6 qt	5 qt	5.7	
		VK50VE	7-5/8 qt	6-3/8 qt	7.2	
Cooling system	With reservoir tank	VQ35HR	9-3/4 qt	8-1/8 qt	9.2	Genuine NISSAN Long Life Antifreeze/ Coolant or equivalent
		VK50VE	11-5/8 qt	9-5/8 qt	11	
	Reservoir tank	VQ35HR	7/8 qt	3/4 qt	0.8	
		VK50VE	7/8qt	3/4 qt	0.8	
Automatic transmission fluid		VQ35HR	9-3/4 qt* <sup>8</sup>	8-1/8 qt* <sup>8</sup>	9.2* <sup>8</sup>	Genuine NISSAN Matic S ATF * <sup>2</sup>
		VK50VE	12 qt* <sup>8</sup>	10 qt* <sup>8</sup>	11.3* <sup>8</sup>	
Differential gear oil	Front		1-3/8 pt	1-1/8 pt	0.65	Genuine NISSAN Differential Oil Hypoid Super GL-5 80W-90 or API GL-5, Viscosity SAE 80W-90 * <sup>3</sup>
	Rear	VQ35HR	3 pt	2-1/2 pt	1.40	VQ35HR except towing package: Genuine NISSAN Differential Oil Hypoid Super GL-5 80W-90 or API GL-5, Viscosity SAE 80W-90* <sup>3</sup>
		VK50VE	3-3/4 pt	3-1/8 pt	1.75	VK50VE and VQ35HR with towing pack- age: Genuine NISSAN differential oil synthetic 75W-90 or API GL-5 synthetic gear oil, Vis- cosity SAE 75W-90* <sup>4</sup>
Transfer fluid			2-1/8 pt	1-3/4 pt	1.0	Genuine NISSAN Matic J ATF* <sup>5</sup>
Power steering fluid (PSF)			1-1/8 qt	7/8 qt	1.0	Genuine NISSAN PSF or equivalent* <sup>6</sup>
Brake fluid			—	—	—	Genuine NISSAN Super Heavy Duty Brake Fluid* <sup>7</sup> or equivalent DOT 3 (US FMVSS No. 116)
Multi-purpose grease			—	—	—	NLGI No. 2 (Lithium soap base)
Windshield washer fluid			—	—	—	Genuine NISSAN Windshield Washer Con- centrate Cleaner & Antifreeze or equivalent
Fuel recommendation			—	—	—	Refer to <a href="#">GI-25, "Fuel"</a> .

\*1: For further details, see "Engine Oil Recommendation".

\*2: Using automatic transmission fluid other than Genuine NISSAN Matic S ATF will cause deterioration in driveability and automatic transmission durability, and may damage the automatic transmission, which is not covered by the INFINITI new vehicle limited warranty.

\*3: For hot climates, viscosity SAE 90 is suitable for ambient temperatures above 0°C (32°F).

\*4: See an INFINITI dealer for service for synthetic oil.

\*5: Using transfer fluid other than Genuine NISSAN Matic J ATF will cause deterioration in driveability and transfer durability, and may damage the transfer, which is not covered by the INFINITI new vehicle limited warranty.

\*6: DEXRON™ VI type ATF or Canada NISSAN Automatic Transmission Fluid may also be used.

\*7: Available in mainland U.S.A. through an INFINITI dealer.

# RECOMMENDED FLUIDS AND LUBRICANTS

## < PERIODIC MAINTENANCE >

\*8: The fluid capacity is the reference value.

### Engine Oil Recommendation

INFOID:000000004001298

NISSAN recommends the use of an energy conserving oil in order to improve fuel economy. Select only engine oils that meet the American Petroleum Institute (API) certification and International Lubricant Standardization and Approval Committee (ILSAC) certification and SAE viscosity standard. These oils have the API certification mark on the front of the container. Oils which do not have the specified quality label should not be used as they could cause engine damage.

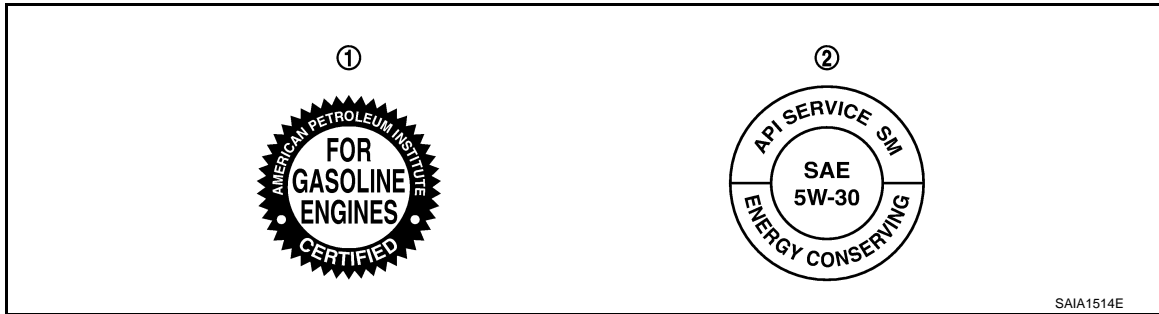

1. API certification mark
2. API service symbol

### Anti-Freeze Coolant Mixture Ratio

INFOID:000000004001299

The engine cooling system is filled at the factory with a high-quality, year-round, anti-freeze coolant solution. The anti-freeze solution contains rust and corrosion inhibitors. Therefore, additional cooling system additives are not necessary.

**CAUTION:**

**When adding or replacing coolant, be sure to use only Genuine NISSAN Long Life Antifreeze/ Coolant or equivalent with the proper mixture ratio of 50% anti-freeze and 50% demineralized water/distilled water.**

**Other types of coolant solutions may damage your cooling system.**

Outside temperature down to		Anti-freeze	Demineralized water or distilled water
°C	°F		
-35	-30	50%	50%

SMA947CA

# ENGINE MAINTENANCE (VQ35HR)

< PERIODIC MAINTENANCE >

## ENGINE MAINTENANCE (VQ35HR)

### DRIVE BELT

#### DRIVE BELT : Exploded View

INFOID:000000004054931

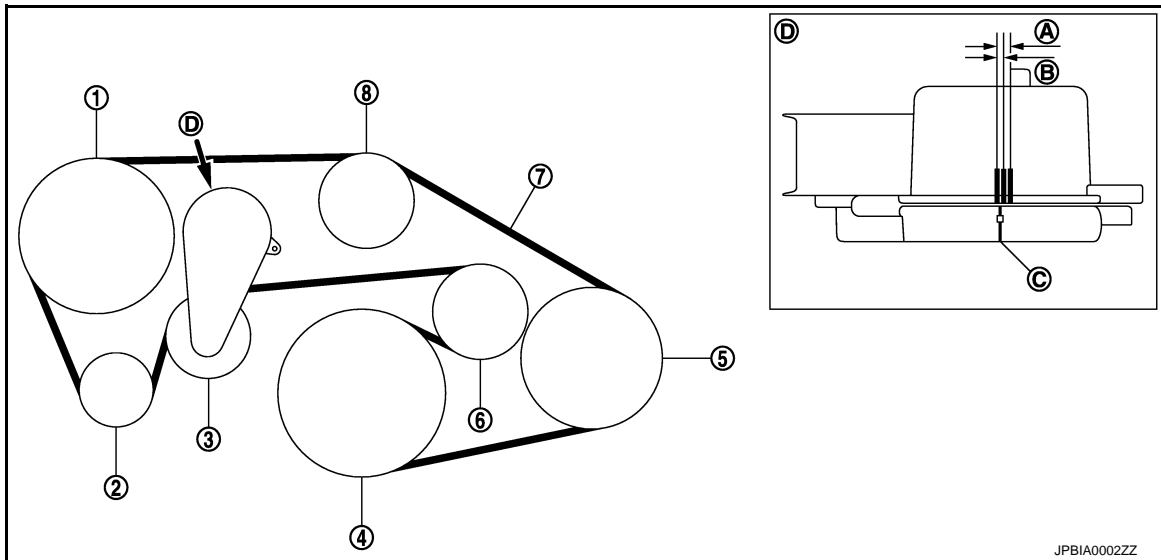

- |                            |   |                              |
|----------------------------|---|------------------------------|
| 1. Power steering oil pump | 2. Alternator                             | 3. Drive belt auto-tensioner |
| 4. Crankshaft pulley       | 5. A/C compressor                         | 6. Idler pulley              |
| 7. Drive belt              | 8. Idler pulley                           |                              |
| A. Possible use range      | B. Range when new drive belt is installed | C. Indicator                 |
| D. View D                  |   |                              |

#### DRIVE BELT : Checking

INFOID:000000004054932

#### **WARNING:**

**Be sure to perform this step when engine is stopped.**

- Check that the indicator (C) (notch on fixed side) of drive belt auto-tensioner is within the possible use range (A).

#### **NOTE:**

- Check the drive belt auto-tensioner indication when the engine is cold.
- When new drive belt is installed, the indicator (notch on fixed side) should be within the range (B) in the figure.
- Visually check entire drive belt for wear, damage or cracks.
- If the indicator (notch on fixed side) is out of the possible use range or belt is damaged, replace drive belt.

#### DRIVE BELT : Tension Adjustment

INFOID:000000004054933

Refer to [EM-142. "Drive Belt"](#).

### ENGINE COOLANT

#### ENGINE COOLANT : Draining

INFOID:000000004001377

#### **WARNING:**

- **Never change engine coolant when the engine is hot to avoid being scalded.**
- **Wrap a thick cloth around radiator cap and carefully remove radiator cap. First, turn radiator cap a quarter of a turn to release built-up pressure. Then turn radiator cap all the way.**

# ENGINE MAINTENANCE (VQ35HR)

## < PERIODIC MAINTENANCE >

1. Open radiator drain plug (2) at the bottom of radiator, and then remove radiator cap.

- 1 : Engine under cover
- A : Radiator drain plug hole
- ← : Vehicle front

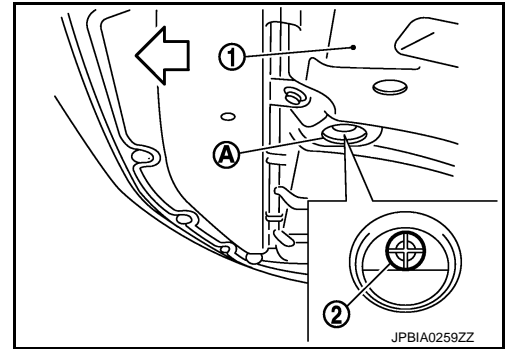

**When draining all of engine coolant in the system, open water drain plugs on cylinder block. Refer to [EM-92, "Setting"](#).**

2. Remove reservoir tank as necessary, and drain engine coolant and clean reservoir tank before installing.
3. Check drained engine coolant for contaminants such as rust, corrosion or discoloration. If contaminated, flush the engine cooling system. Refer to [MA-25, "ENGINE COOLANT : Flushing"](#).

## ENGINE COOLANT : Refilling

INFOID:000000004001378

1. Remove engine cover. Refer to [EM-27, "Exploded View"](#).
2. Install reservoir tank if removed, and radiator drain plug.  
**CAUTION:**  
Be sure to clean drain plug and install with new O-ring.

**Tightening torque** : Refer to [CO-14, "Exploded View"](#).

**If water drain plugs on cylinder block are removed, close and tighten them. Refer to [EM-118, "Disassembly and Assembly"](#).**

3. Check that each hose clamp is firmly tightened.
4. Remove air relief plug (2) on radiator left side.

- 1 : Reservoir tank
- 3 : Engine cover
- ← : Vehicle front

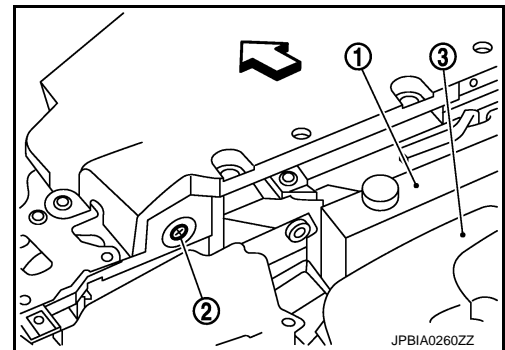

5. Remove air relief plug (1) on heater hose. (models with air relief plug on heater hose)

- 2 : Heater hose
- ← : Vehicle front

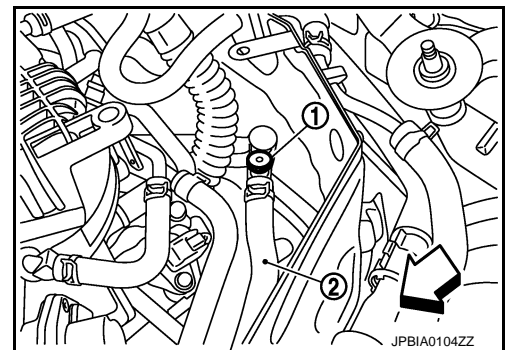

A  
B  
C  
D  
E  
F  
G  
H  
I  
J  
K  
L  
M  
N  
O  
MA

# ENGINE MAINTENANCE (VQ35HR)

## < PERIODIC MAINTENANCE >

6. Fill radiator, and reservoir tank if removed, to specified level.
  - Pour engine coolant through engine coolant filler neck slowly of less than 2 ℓ (2-1/8 US qt, 1-3/4 Imp qt) a minute to allow air in system to escape.
  - Use Genuine NISSAN Long Life Antifreeze/Coolant or an equivalent mixed with water (distilled or demineralized). Refer to [MA-12, "Fluids and Lubricants"](#).

Engine coolant capacity (With reservoir tank at "MAX" level) : Refer to [CO-26, "Periodical Maintenance Specification"](#).

Reservoir tank engine coolant capacity (At "MAX" level) : Refer to [CO-26, "Periodical Maintenance Specification"](#).

A : MAX  
B : MIN

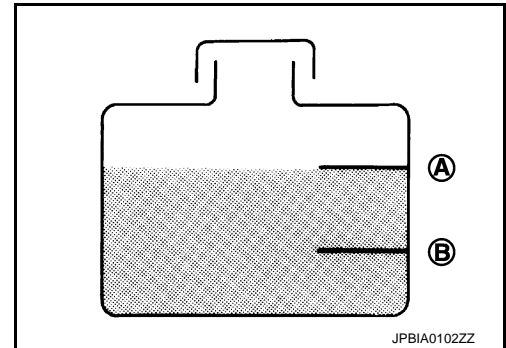
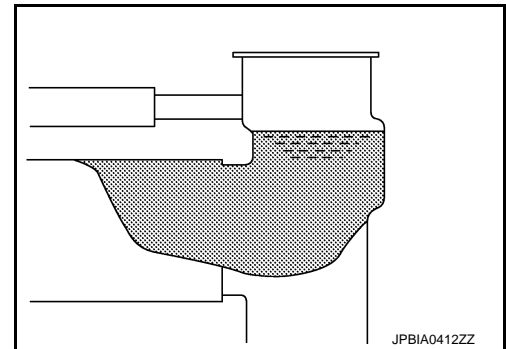

7. When engine coolant overflows air relief hole on radiator, install air relief plug with new O-ring.

Tightening torque : Refer to [CO-14, "Exploded View"](#).

8. Repeat step 6.
9. When engine coolant overflows air relief hole on heater hose, install air relief plug with new O-ring. Then refill radiator with engine coolant. (models with air relief plug on heater hose)

 : 1.2 N-m (0.12 kg-m, 11 in-lb)

10. Install radiator cap.
11. Warm up engine until opening thermostat. Standard for warming-up time is approximately 10 minutes at 3,000 rpm.
  - Check thermostat opening condition by touching radiator hose (lower) to see a flow of warm water.**CAUTION:**  
**Watch water temperature gauge so as not to overheat engine.**
12. Stop the engine and cool down to less than approximately 50°C (122°F).
  - Cool down using fan to reduce the time.
  - If necessary, refill radiator up to filler neck with engine coolant.
13. Refill reservoir tank to "MAX" level line with engine coolant.
14. Repeat steps 10 through 13 two or more times with radiator cap installed until engine coolant level no longer drops.
15. Check cooling system for leakage with engine running.
16. Warm up the engine, and check for sound of engine coolant flow while running engine from idle up to 3,000 rpm with heater temperature controller set at several position between "COOL" and "WARM".
  - Sound may be heard from the heater unit.
17. Repeat step 16 three times.
18. If sound is heard, bleed air from cooling system by repeating step 6, and steps from 10 to 17 until engine coolant level no longer drops.
19. Check that the reservoir tank cap is tightened.

## ENGINE COOLANT : Flushing

INFOID:000000004001379

1. Install reservoir tank if removed, and radiator drain plug.



# ENGINE MAINTENANCE (VQ35HR)

## < PERIODIC MAINTENANCE >

### CAUTION:

Be sure to clean drain plug and install with new O-ring.

**Tightening torque** : Refer to [CO-14, "Exploded View"](#).

If water drain plugs on cylinder block are removed, close and tighten them. Refer to [EM-118, "Disassembly and Assembly"](#).

2. Remove air relief plug (1) on heater hose. (models with air relief plug on heater hose)

2 : Heater hose

↔ : Vehicle front

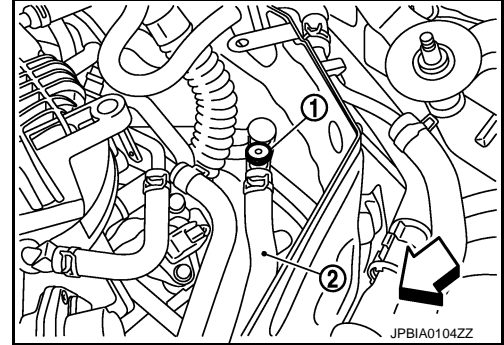

3. Remove air relief plug (2) on radiator.

1 : Reservoir tank

3 : Engine cover

↔ : Vehicle front

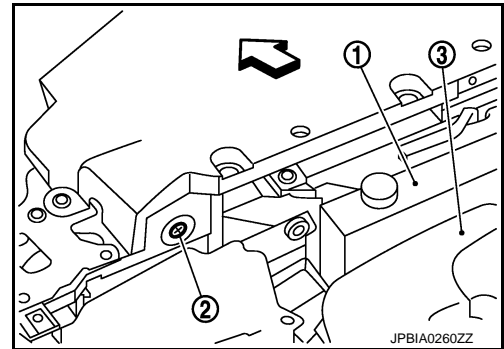

4. Fill radiator with water until water spills from the air relief holes, then close air relief plugs. Fill radiator and reservoir tank with water and reinstall radiator cap.

**Tightening torque** : Refer to [CO-14, "Exploded View"](#).

5. Run the engine and warm it up to normal operating temperature.
6. Rev the engine two or three times under no-load.
7. Stop the engine and wait until it cools down.
8. Drain water from the system. Refer to [MA-23, "ENGINE COOLANT : Draining"](#).
9. Repeat steps 1 through 8 until clear water begins to drain from radiator.
10. Check that the reservoir tank cap is tightened.

## FUEL LINES

### FUEL LINES : Inspection

INFOID:000000004001380

- Inspect fuel lines, fuel filler cap and fuel tank for improper attachment, leakage, cracks, damage, loose connections, chafing or deterioration.

A : Engine

B : Fuel line

C : Fuel tank

- If necessary, repair or replace damaged parts.

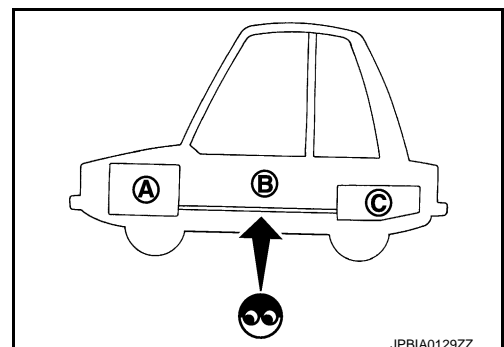

## AIR CLEANER FILTER

A  
B  
C  
D  
E  
F  
G  
H  
I  
J  
K  
L  
M  
N  
O

MA

# ENGINE MAINTENANCE (VQ35HR)

< PERIODIC MAINTENANCE >

## AIR CLEANER FILTER : Removal and Installation

INFOID:000000004054934

### REMOVAL

1. Unhook clips (A).

- 1 : Holder
- 2 : Air cleaner case

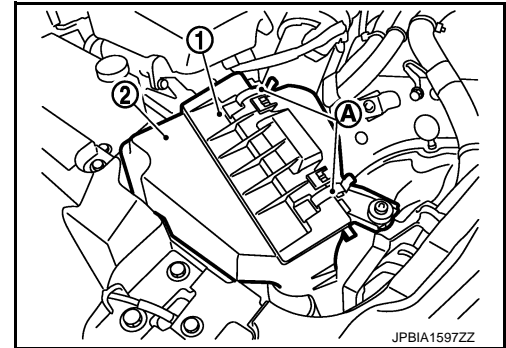

2. Remove holder (3) from air cleaner case (2), and then remove air cleaner filter (1) from holder.

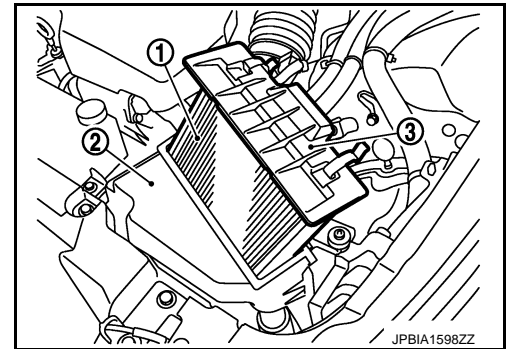

### INSTALLATION

Note the following item, and install in the reverse order of removal.

- Install the air cleaner filter by aligning the seal with the notch of air cleaner case.

### ENGINE OIL

#### ENGINE OIL : Draining

INFOID:000000004001381

#### **WARNING:**

- Be careful not to get burned, as engine oil may be hot.
- Prolonged and repeated contact with used engine oil may cause skin cancer. Try to avoid direct skin contact with used engine oil. If skin contact is made, wash thoroughly with soap or hand cleaner as soon as possible.

1. Warm up the engine, and check for engine oil leakage from engine components. Refer to [LU-25, "Inspection"](#).
2. Stop the engine and wait for 10 minutes.
3. Loosen oil filler cap.
4. Remove undercover with power tool.
5. Remove drain plug and then drain engine oil.

#### ENGINE OIL : Refilling

INFOID:000000004001382

1. Install drain plug with new washer. Refer to [EM-46, "Exploded View"](#).

#### **CAUTION:**

Be sure to clean drain plug and install with new washer.

**Tightening torque** : Refer to [EM-46, "Exploded View"](#).

2. Refill with new engine oil.  
**Engine oil specification and viscosity:** Refer to [MA-12, "Fluids and Lubricants"](#).

# ENGINE MAINTENANCE (VQ35HR)

< PERIODIC MAINTENANCE >

Engine oil capacity : Refer to [LU-33, "Periodical Maintenance Specification"](#).

## CAUTION:

- When filling engine oil, never pull out oil level gauge.
  - The refill capacity depends on the engine oil temperature and drain time. Use these specifications for reference only.
  - Always use oil level gauge to determine the proper amount of engine oil in engine.
3. Warm up the engine and check area around drain plug and oil filter for engine oil leakage.
  4. Stop the engine and wait for 10 minutes.
  5. Check the engine oil level. Refer to [LU-6, "Inspection"](#).

## OIL FILTER

### OIL FILTER : Removal and Installation

INFOID:000000004001383

#### REMOVAL

##### CAUTION:

- Oil filter is provided with relief valve. Use genuine NISSAN oil filter or an equivalent.
- Be careful not to get burned when engine and engine oil may be hot.
- When removing, prepare a shop cloth to absorb any engine oil leakage or spillage.
- Never allow engine oil to adhere to drive belt.
- Completely wipe off any engine oil that adheres to engine and vehicle.

1. Remove engine undercover with power tool.
2. Using oil filter wrench [SST: KV10115801 (J38956)] (B), remove oil filter.

A : 2WD models

↔ : Vehicle front

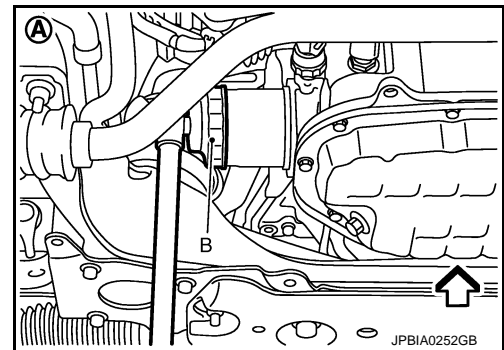

A : AWD models

↔ : Vehicle front

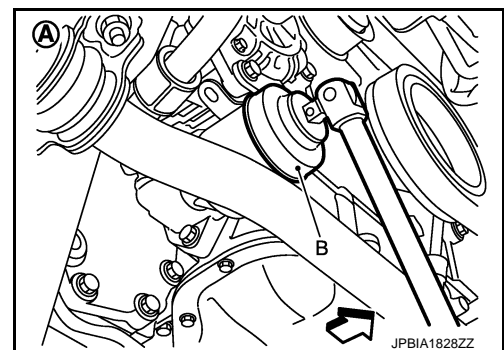

#### INSTALLATION

1. Remove foreign matter adhering to oil filter installation surface.

A  
B  
C  
D  
E  
F  
G  
H  
I  
J  
K  
L  
M  
N  
O

MA

# ENGINE MAINTENANCE (VQ35HR)

## < PERIODIC MAINTENANCE >

2. Apply engine oil to the oil seal contact surface of new oil filter.

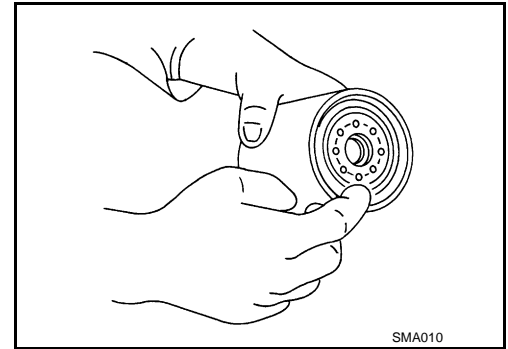

3. Screw oil filter manually until it touches the installation surface, then tighten it by 2/3 turn (A). Or tighten to the specification.

### Oil filter:

: 17.7 N·m (1.8 kg-m, 13 ft-lb)

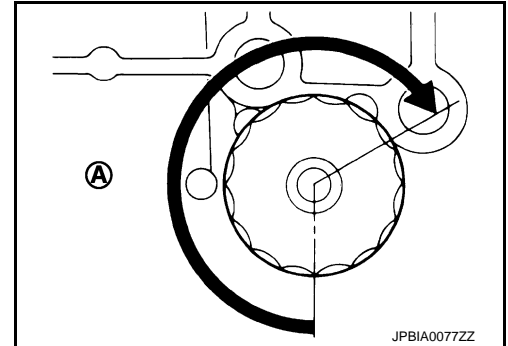

## OIL FILTER : Inspection

INFOID:000000004001384

### INSPECTION AFTER INSTALLATION

1. Check the engine oil level. Refer to [LU-25, "Inspection"](#).
2. Start the engine, and check there is no leakage of engine oil.
3. Stop the engine and wait for 10 minutes.
4. Check the engine oil level, and adjust the level. Refer to [LU-25, "Inspection"](#).

## SPARK PLUG

### SPARK PLUG : Removal and Installation

INFOID:000000004054935

#### REMOVAL

1. Remove engine cover with power tool. Refer to [EM-27, "Exploded View"](#).
2. Remove air duct. Refer to [EM-29, "Exploded View"](#).
3. Remove electric throttle control actuator. Refer to [EM-31, "Exploded View"](#).
4. Remove ignition coil. Refer to [EM-50, "Removal and Installation"](#).
5. Remove spark plug with a spark plug wrench (commercial service tool).

a : 14 mm (0.55 in)

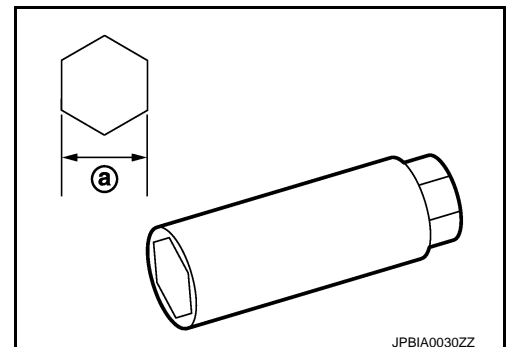

#### INSTALLATION

Installation is the reverse order of removal.

# ENGINE MAINTENANCE (VQ35HR)

< PERIODIC MAINTENANCE >

## SPARK PLUG : Inspection

INFOID:000000004054936

### INSPECTION AFTER REMOVAL

Use the standard type spark plug for normal condition.

Spark plug (Standard type) : Refer to [EM-143, "Spark Plug"](#).

#### CAUTION:

- Never drop or impact spark plug.
- Never use a wire brush for cleaning.
- If plug tip is covered with carbon, spark plug cleaner may be used.

Cleaner air pressure: Less than 588 kPa (6 kg/cm<sup>2</sup>, 85 psi)

Cleaning time: Less than 20 seconds

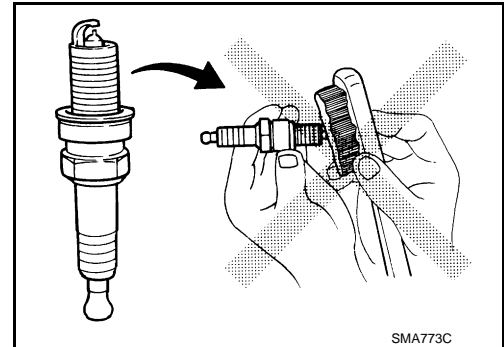

- Measure spark plug gap. When it exceeds the limit, replace spark plug even if it is within the specified replacement mileage. Refer to [EM-143, "Spark Plug"](#).
- Spark plug gap adjustment is not required between replacement intervals.

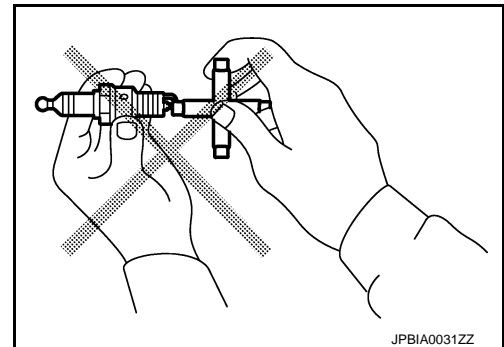

## EVAP VAPOR LINES

### EVAP VAPOR LINES : Inspection

INFOID:000000004001314

1. Visually inspect EVAP vapor lines for improper attachment and for cracks, damage, loose connections, chafing and deterioration.
2. Inspect fuel tank filler cap vacuum relief valve for clogging, sticking, etc.  
Refer to [EC-568, "Inspection"](#).

# ENGINE MAINTENANCE (VK50VE)

< PERIODIC MAINTENANCE >

## ENGINE MAINTENANCE (VK50VE)

### DRIVE BELTS

#### DRIVE BELTS : Exploded View

INFOID:000000004001363

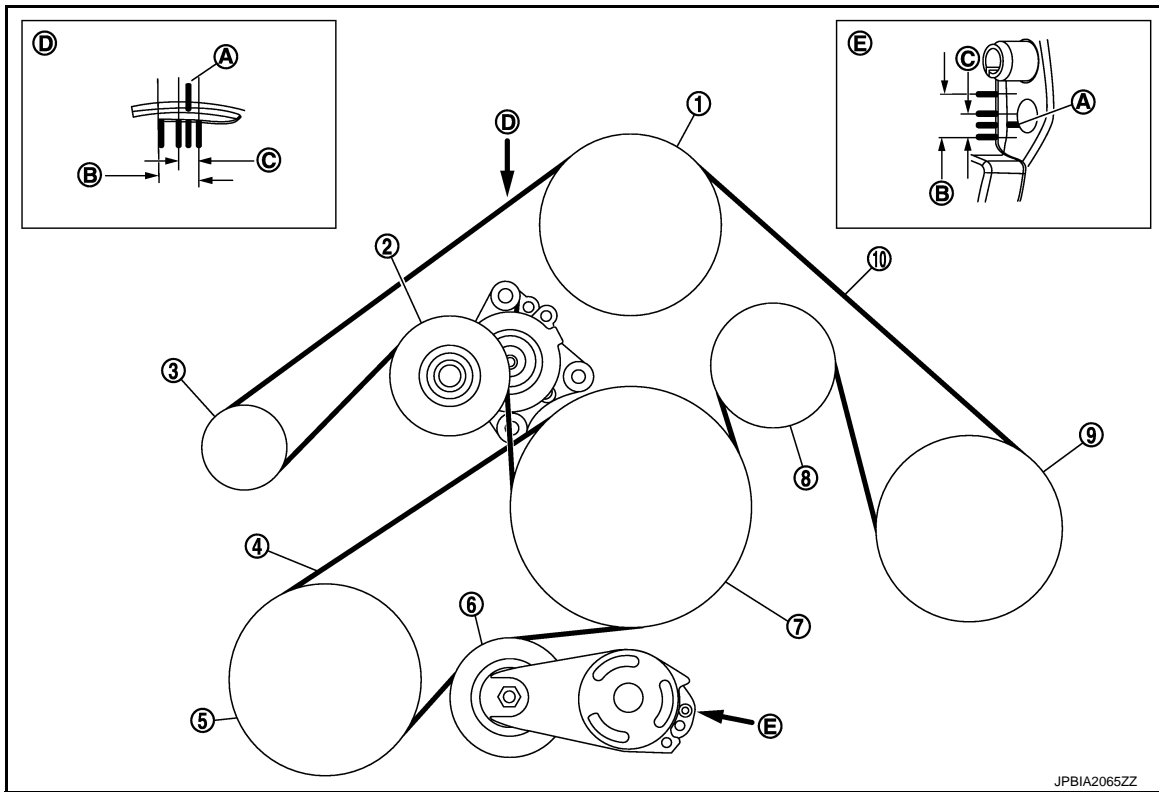

JPBIA2065ZZ

- |  |  |  |
|--|--|--|
| 1. Water pump                                      | 2. Auto-tensioner (for alternator, water pump and A/C compressor belt) | 3. Alternator  |
| 4. Power steering oil pump belt                    | 5. Power steering oil pump   | 6. Auto-tensioner (for power steering oil pump belt) |
| 7. Crankshaft pulley                               | 8. Idler pulley  | 9. A/C compressor                                    |
| 10. Alternator, water pump and A/C compressor belt |  |  |
| A. Indicator                                       | B. Possible use range  | C. Range when new drive belt is installed            |
| D. View D  | E. View E  |  |

#### DRIVE BELTS : Checking

INFOID:000000004001364

##### **WARNING:**

**Be sure to perform the these steps when engine is stopped.**

- Remove air duct (inlet) when inspecting alternator, water pump and A/C compressor belt.
- Remove engine undercover with power tool when inspecting power steering oil pump belt.
- Check that the indicator (A) (notch on fixed side) of each auto-tensioner is within the possible use range (B).

##### **NOTE:**

- Check the each auto-tensioners indication when the engine is cold.
- When new drive belts is installed, the indicator (notch on fixed side) should be within the range (C) in the figure.
- Visually check all drive belts for wear, damage or cracks.
- If the indicator (notch on fixed side) is out of the possible use range or drive belts are damaged, replace drive belts.

# ENGINE MAINTENANCE (VK50VE)

< PERIODIC MAINTENANCE >

## DRIVE BELTS : Tension Adjustment

INFOID:000000004001365

Refer to [EM-282. "Drive Belts"](#).

## ENGINE COOLANT

### ENGINE COOLANT : Draining

INFOID:000000004001366

#### WARNING:

- Never change engine coolant when the engine is hot to avoid being scalded.
- Wrap a thick cloth around radiator cap and carefully remove radiator cap. First, turn radiator cap a quarter of a turn to release built-up pressure. Then turn radiator cap all the way.

1. Open radiator drain plug (2) at the bottom of radiator, and then remove radiator cap.

- 1 : Engine under cover  
A : Radiator drain plug hole  
↶ : Vehicle front

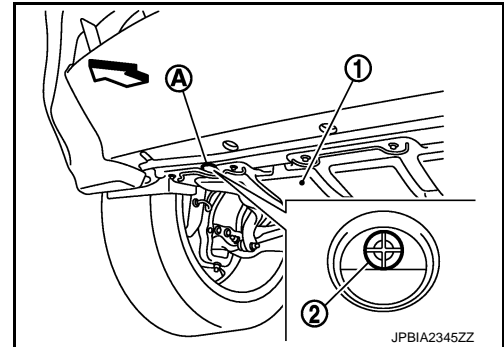

When draining all of engine coolant in the system, open water drain plug on cylinder block. Refer to [EM-202. "Setting"](#).

2. Remove reservoir tank if necessary, and drain engine coolant and clean reservoir tank before installing.
3. Check drained engine coolant for contaminants such as rust, corrosion or discoloration. If contaminated, flush the engine cooling system. Refer to [MA-25. "ENGINE COOLANT : Flushing"](#).

### ENGINE COOLANT : Refilling

INFOID:000000004001367

1. Remove engine cover and engine room cover (LH). Refer to [EM-174. "Exploded View"](#).
2. Install reservoir tank if removed, and radiator drain plug.

#### CAUTION:

Be sure to clean drain plug and install with new O-ring.

 : 1.2 N·m (0.12 kg·m, 11 in·lb)

If water drain plug on cylinder block is removed, close and tighten it. Refer to [EM-255. "Exploded View"](#).

3. Check that each hose clamp is firmly tightened.
4. Remove air relief plug (2) on radiator left side.

- 1 : Reservoir tank  
3 : Water inlet  
↶ : Vehicle front

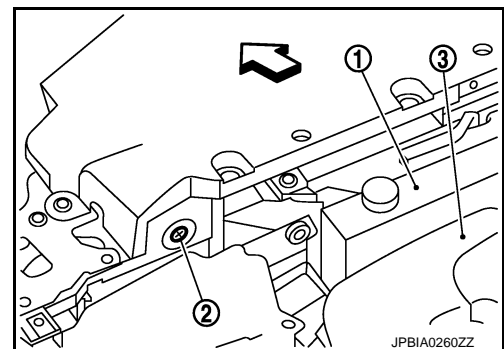

## ENGINE MAINTENANCE (VK50VE)

### < PERIODIC MAINTENANCE >

5. Remove air relief plug (1) on heater hose.

↶ : Vehicle front

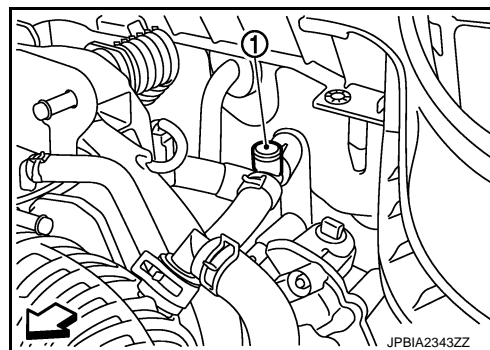

6. Fill water inlet, and reservoir tank if removed, to specified level.
- Pour engine coolant through engine coolant filler neck slowly of less than 2 ℓ (2-1/8 US qt, 1-3/4 Imp qt) a minute to allow air in system to escape.
  - Use Genuine NISSAN Long Life Antifreeze/Coolant or an equivalent mixed with water (distilled or demineralized). Refer to [MA-12, "Fluids and Lubricants"](#).

Engine coolant capacity  
(With reservoir tank at  
"MAX" level)

: Refer to [CO-49,](#)  
["Periodical Maintenance](#)  
[Specification"](#).

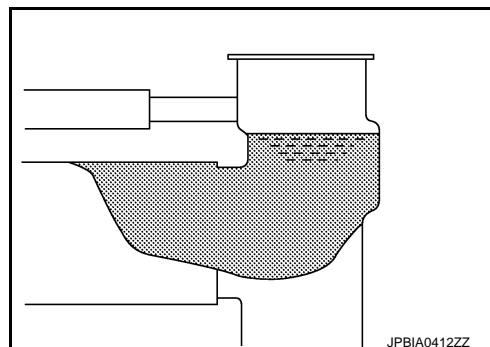

Reservoir tank engine cool-  
ant capacity  
(At "MAX" level)

:Refer to [CO-49,](#)  
["Periodical Maintenanc](#)  
[e Specification"](#).

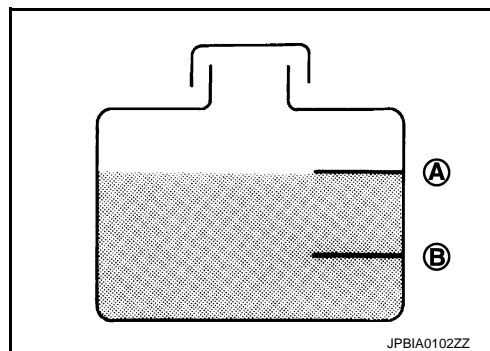

A : MAX  
B : MIN

7. When engine coolant overflows air relief hole on radiator, install air relief plug with new O-ring.

 : 1.2 N-m (0.12 kg-m, 11 in-lb)

8. Repeat step 6.
9. When engine coolant overflows air relief hole on heater hose, install air relief plug with new O-ring. Then refill radiator with engine coolant.

 : 1.2 N-m (0.12 kg-m, 11 in-lb)

10. Install radiator cap.
11. Warm up engine until opening thermostat. Standard for warming-up time is approximately 10 minutes at 3,000 rpm.
- Check thermostat opening condition by touching radiator hose (lower) to see a flow of warm water.
- CAUTION:**  
**Watch water temperature gauge so as not to overheat engine.**
12. Stop the engine and cool down to less than approximately 50°C (122°F).
- Cool down using fan to reduce the time.
  - If necessary, refill radiator up to filler neck with engine coolant.
13. Refill reservoir tank to "MAX" level line with engine coolant.
14. Repeat steps 10 through 13 two or more times with radiator cap installed until engine coolant level no longer drops.



# ENGINE MAINTENANCE (VK50VE)

## < PERIODIC MAINTENANCE >

15. Check cooling system for leakage with engine running.
16. Warm up the engine, and check for sound of engine coolant flow while running engine from idle up to 3,000 rpm with heater temperature controller set at several position between "COOL" and "WARM".
  - Sound may be heard from the heater unit.
17. Repeat step 16 three times.
18. If sound is heard, bleed air from cooling system by repeating step 6, and steps from 10 to 17 until engine coolant level no longer drops.
19. Check that the reservoir tank cap is tightened.

## ENGINE COOLANT : Flushing

INFOID:000000004001368

1. Install reservoir tank if removed, and radiator drain plug.  
**CAUTION:**  
Be sure to clean drain plug and install with new O-ring.

 : 1.2 N-m (0.12 kg-m, 11 in-lb)

If water drain plug on cylinder block is removed, close and tighten it. Refer to [EM-255, "Exploded View"](#).

2. Remove air relief plug (1) on heater hose.

 : Vehicle front

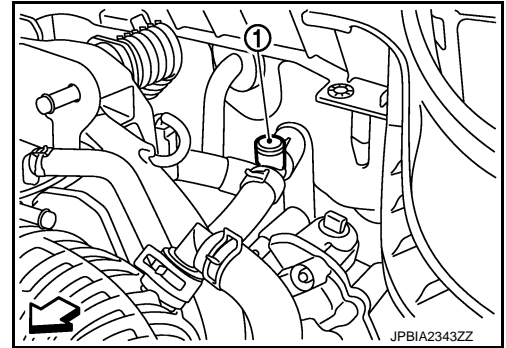

3. Remove air relief plug (2) on radiator.

1 : Reservoir tank

3 : Water inlet

 : Vehicle front

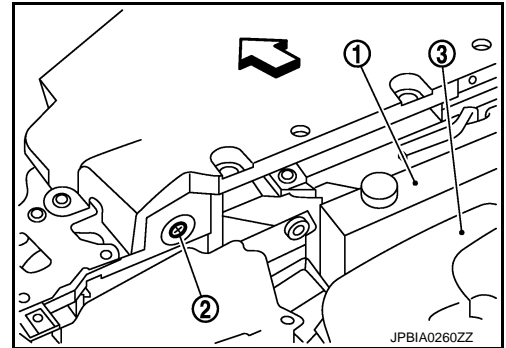

4. Fill water inlet with water until water spills from the air relief holes, then close air relief plugs. Fill water inlet and reservoir tank with water and reinstall radiator cap.

 : 1.2 N-m (0.12 kg-m, 11 in-lb)

5. Run the engine and warm it up to normal operating temperature.
6. Rev the engine two or three times under no-load.
7. Stop the engine and wait until it cools down.
8. Drain water from the system. Refer to [MA-23, "ENGINE COOLANT : Draining"](#).
9. Repeat steps 1 through 8 until clear water begins to drain from radiator.
10. Check that the reservoir tank cap is tightened.

## FUEL LINES

# ENGINE MAINTENANCE (VK50VE)

## < PERIODIC MAINTENANCE >

### FUEL LINES : Inspection

INFOID:000000004001369

- Inspect fuel lines, fuel filler cap and fuel tank for improper attachment, leakage, cracks, damage, loose connections, chafing or deterioration.

- A : Engine
- B : Fuel line
- C : Fuel tank

- If necessary, repair or replace damaged parts.

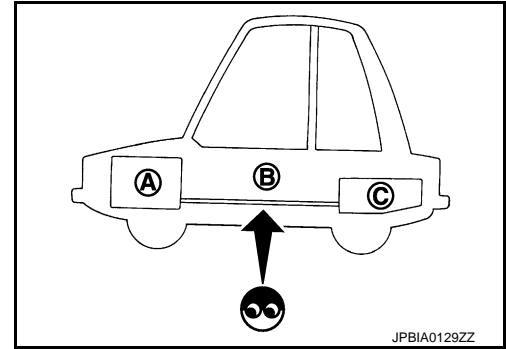

### AIR CLEANER FILTER

### AIR CLEANER FILTER : Removal and Installation

INFOID:000000004001370

#### REMOVAL

1. Unhook clips (A).

- 1 : Holder
- 2 : Air cleaner case

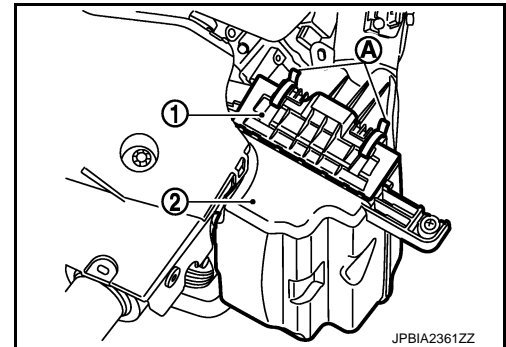

2. Remove air cleaner filter (2) from air cleaner case (3).

- 1 : Holder

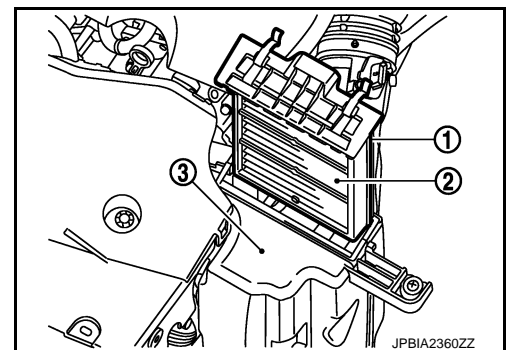

#### INSTALLATION

Note the following item, and install in the reverse order of removal.

- Install the air cleaner filter by aligning the seal with the notch of air cleaner case.

### ENGINE OIL

### ENGINE OIL : Draining

INFOID:000000004001371

#### **WARNING:**

- **Be careful not to get burned, as engine oil may be hot.**
- **Prolonged and repeated contact with used engine oil may cause skin cancer. Try to avoid direct skin contact with used engine oil. If skin contact is made, wash thoroughly with soap or hand cleaner as soon as possible.**

1. Warm up the engine, and check for engine oil leakage from engine components. Refer to [LU-25, "Inspection"](#).
2. Stop the engine and wait for 15 minutes.
3. Loosen oil filler cap.

# ENGINE MAINTENANCE (VK50VE)

## < PERIODIC MAINTENANCE >

4. Remove drain plug and then drain engine oil.

## ENGINE OIL : Refilling

INFOID:000000004001372

1. Install drain plug with new washer.

### **CAUTION:**

**Be sure to clean drain plug and install with new washer.**

**Tightening torque** : Refer to [EM-188, "Exploded View"](#).

2. Refill with new engine oil.

### **Engine oil specification and viscosity:**

Refer to [LU-33, "Periodical Maintenance Specification"](#).

**Engine oil capacity** : Refer to [LU-33, "Periodical Maintenance Specification"](#).

### **CAUTION:**

- The refill capacity depends on the engine oil temperature and drain time. Use these specifications for reference only.
- Always use oil level gauge to determine the proper amount of engine oil in engine.

3. Warm up the engine and check area around drain plug and oil filter for engine oil leakage.
4. Stop the engine and wait for 15 minutes.
5. Check the engine oil level. Refer to [LU-25, "Inspection"](#).

## OIL FILTER

### OIL FILTER : Removal and Installation

INFOID:000000004001373

#### REMOVAL

### **CAUTION:**

- Oil filter is provided with relief valve. Use genuine NISSAN oil filter or an equivalent.
- Be careful not to get burned when engine and engine oil may be hot.
- When removing, prepare a shop cloth to absorb any engine oil leakage or spillage.
- Never allow engine oil to adhere to drive belts.
- Completely wipe off any engine oil that adheres to engine and vehicle.

1. Remove engine undercover with power tool.
2. Using oil filter wrench [SST: KV10115801 (J38956)] (A), remove oil filter.

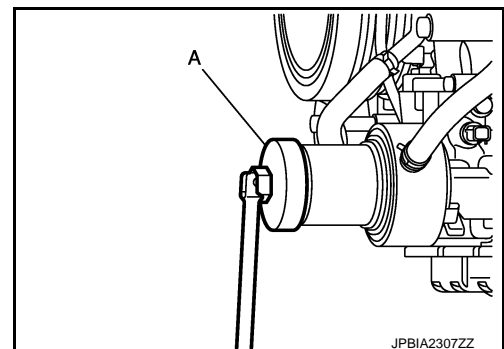

#### INSTALLATION

1. Remove foreign matter adhering to oil filter installation surface.

A

B

C

D

E

F

G

H

I

J

K

L

M

N

O

MA

# ENGINE MAINTENANCE (VK50VE)

## < PERIODIC MAINTENANCE >

2. Apply engine oil to the oil seal contact surface of new oil filter.

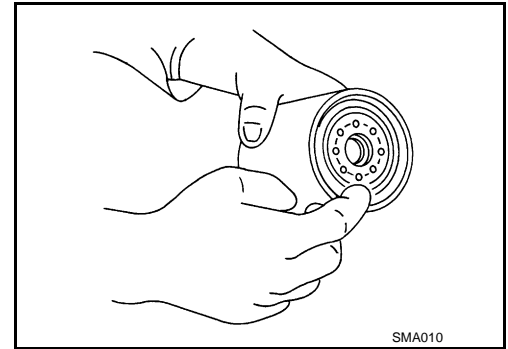

3. Screw oil filter manually until it touches the installation surface, then tighten it by 2/3 turn (A). Or tighten to the specification.

### Oil filter:

: 17.7 N·m (1.8 kg-m, 13 ft-lb)

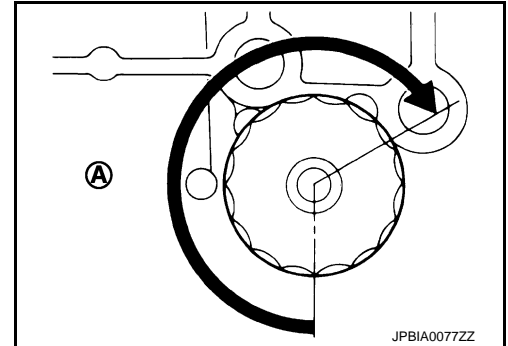

## OIL FILTER : Inspection

INFOID:000000004001374

### INSPECTION AFTER INSTALLATION

1. Check the engine oil level. Refer to [LU-25, "Inspection"](#).
2. Start the engine, and check there is no leakage of engine oil.
3. Stop the engine and wait for 15 minutes.
4. Check the engine oil level, and adjust the level. Refer to [LU-25, "Inspection"](#).

## SPARK PLUG

### SPARK PLUG : Removal and Installation

INFOID:000000004001375

#### REMOVAL

1. Remove engine cover. Refer to [EM-179, "Exploded View"](#).
2. Remove ignition coil. Refer to [EM-191, "Exploded View"](#).
3. Remove spark plug with a spark plug wrench (commercial service tool).

a : 14 mm (0.55 in)

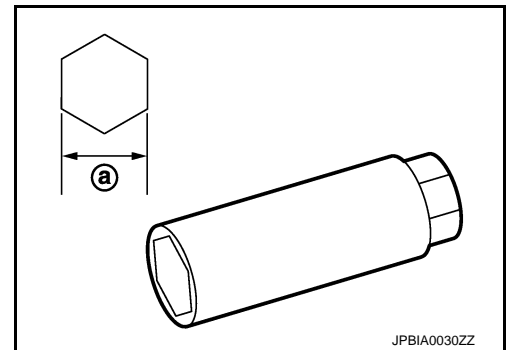

#### INSTALLATION

Installation is the reverse order of removal.

### SPARK PLUG : Inspection

INFOID:000000004001376

#### INSPECTION AFTER REMOVAL

Use the standard type spark plug for normal condition.

# ENGINE MAINTENANCE (VK50VE)

## < PERIODIC MAINTENANCE >

Spark plug (Standard type) : Refer to [EM-282, "Spark Plug"](#).

**CAUTION:**

- Never drop or impact spark plug.
- Never use a wire brush for cleaning.
- If plug tip is covered with carbon, use spark plug cleaner to clean.

Cleaner air pressure

: Less than 588 kPa (6 kg/cm<sup>2</sup>, 85 psi)

Cleaning time

: Less than 20 seconds

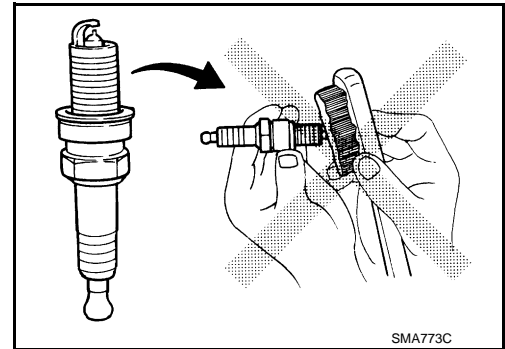

- Measure spark plug gap. When it exceeds the limit, replace spark plug even if it is within the specified replacement mileage. Refer to [EM-282, "Spark Plug"](#).
- Spark plug gap adjustment is not required between replacement intervals.

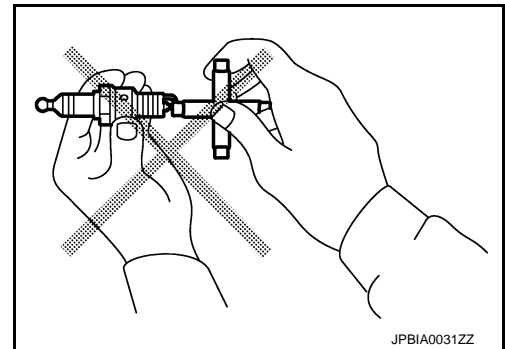

## EVAP VAPOR LINES

### EVAP VAPOR LINES : Inspection

INFOID:000000004001362

1. Visually inspect EVAP vapor lines for improper attachment and for cracks, damage, loose connections, chafing and deterioration.
2. Inspect fuel tank filler cap vacuum relief valve for clogging, sticking, etc.  
Refer to [EC-1229, "Inspection"](#).

# CHASSIS MAINTENANCE

< PERIODIC MAINTENANCE >

## CHASSIS MAINTENANCE

### EXHAUST SYSTEM

#### EXHAUST SYSTEM : Inspection

INFOID:000000004001385

Check exhaust pipes, muffler and mounting for improper attachment, leakage, cracks, damage or deterioration.

- If damage is found, repair or replace damaged parts.

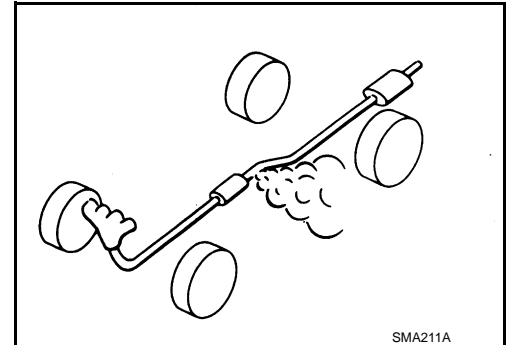

### TRANSFER FLUID

#### TRANSFER FLUID : Inspection

INFOID:000000004001427

#### FLUID LEAKAGE

Check transfer surrounding area (oil seal, drain plug, and filler plug etc.) for fluid leakage.

#### FLUID LEVEL

1. Remove filler plug (1) and gasket. Then check that fluid is filled up from mounting hole for the filler plug.

**CAUTION:**

**Never start engine while checking fluid level.**

2. Set a new gasket onto filler plug, and install it on transfer and tighten to the specified torque. Refer to [DLN-67, "VQ35HR : Exploded View"](#).

**CAUTION:**

**Never reuse gasket.**

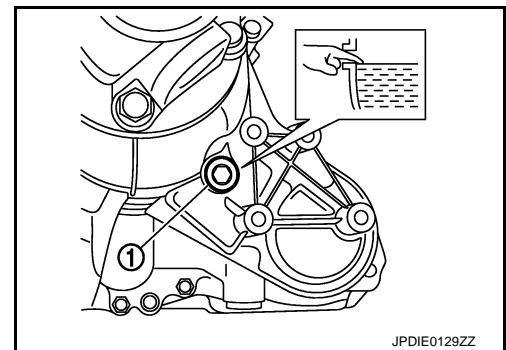

#### TRANSFER FLUID : Draining

INFOID:000000004001428

1. Run the vehicle to warm up the transfer unit sufficiently.
2. Stop the engine, and remove the drain plug (1) to drain the transfer fluid.
3. Set a new gasket onto the drain plug, and install it on the transfer and tighten to the specified torque. Refer to [DLN-67, "VQ35HR : Exploded View"](#).

**CAUTION:**

**Never reuse gasket.**

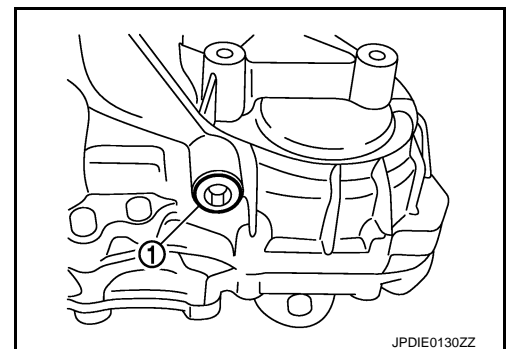

# CHASSIS MAINTENANCE

< PERIODIC MAINTENANCE >

## TRANSFER FLUID : Refilling

INFOID:000000004001429

1. Remove filler plug (1) and gasket. Then fill fluid up to mounting hole for the filler plug.

**Fluid and viscosity** : Refer to [MA-12, "Fluids and Lubricants"](#).

**Fluid capacity** : Refer to [DLN-103, "General Specifications"](#).

**CAUTION:**

**Carefully fill the fluid. (Fill up for approximately 3 minutes.)**

2. Leave the vehicle for 3 minutes, and check the fluid level again.
3. Set a new gasket onto filler plug, and install it on transfer and tighten to the specified torque. Refer to [DLN-67, "VQ35HR : Exploded View"](#).

**CAUTION:**

**Never reuse gasket.**

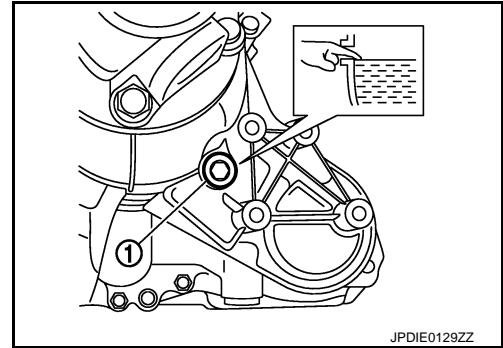

## FRONT PROPELLER SHAFT: 2S56A

### FRONT PROPELLER SHAFT: 2S56A : Inspection

INFOID:000000004001430

#### NOISE

Check the propeller shaft tube surface for dents or cracks. If damaged, replace propeller shaft assembly.

#### VIBRATION

If vibration is present at high speed, inspect propeller shaft runout first.

1. With a dial indicator, measure propeller shaft runout at runout measuring points by rotating final drive companion flange with hands.

**Limit**

**Propeller shaft runout** : Refer to [DLN-112, "Propeller Shaft Runout"](#).

2. If runout still exceeds specifications, separate propeller shaft at final drive companion flange; then rotate companion flange 90, 180, 270 degrees and install propeller shaft.
3. Check runout again. If runout still exceeds specifications, replace propeller shaft assembly.
4. Check the vibration by driving vehicle.

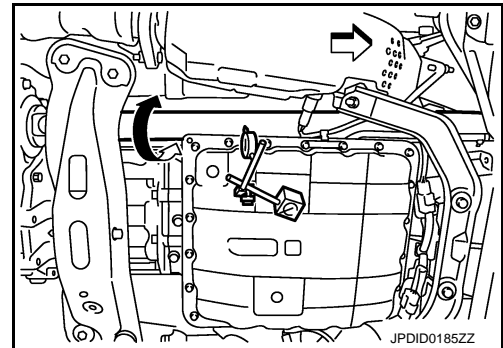

#### RUNOUT MEASURING POINT

Propeller shaft runout measuring point (Point "△").

**Standard**

**A** : 381.5 mm (15.02 in)  
(VQ35HR)  
: 386.5 mm (15.22 in)  
(VK50VE)

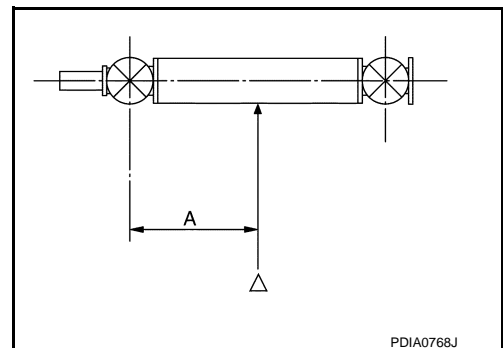

## REAR PROPELLER SHAFT: 3S80A-R

### REAR PROPELLER SHAFT: 3S80A-R : Inspection

INFOID:000000004001431

#### NOISE

A  
B  
C  
D  
E  
F  
G  
H  
I  
J  
K  
L  
M  
N  
O

MA

# CHASSIS MAINTENANCE

## < PERIODIC MAINTENANCE >

- Check the propeller shaft tube surface for dents or cracks. If damaged, replace propeller shaft assembly.
- If center bearing is noisy or damaged, replace propeller shaft assembly.

### VIBRATION

If vibration is present at high speed, inspect propeller shaft runout first.

1. With a dial indicator, measure propeller shaft runout at runout measuring points by rotating final drive companion flange with hands.

#### Limit

**Propeller shaft runout** : Refer to [DLN-120, "Propeller Shaft Runout"](#).

2. If runout still exceeds specifications, separate propeller shaft at final drive companion flange; then rotate companion flange 120, 240 degrees and install propeller shaft.
3. Check runout again. If runout still exceeds specifications, replace propeller shaft assembly.
4. Check the vibration by driving vehicle.

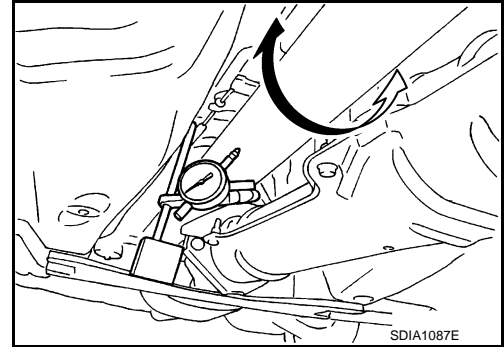

### RUNOUT MEASURING POINT

Propeller shaft runout measuring point (Point "Δ").

⇐: Vehicle front

#### Standard

**A** : 192 mm (7.56 in)

**B** : 172 mm (6.77 in)

**C** : 172 mm (6.77 in)

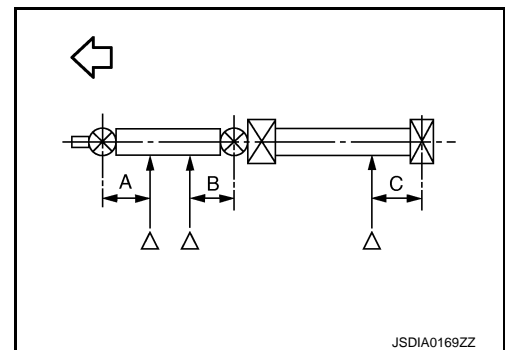

## REAR PROPELLER SHAFT: 3F80A-1VL107

## REAR PROPELLER SHAFT: 3F80A-1VL107 : Inspection

INFOID:000000004001432

### NOISE

- Check the propeller shaft tube surface for dents or cracks. If damaged, replace propeller shaft assembly.
- If center bearing is noisy or damaged, replace propeller shaft assembly.

### VIBRATION

If vibration is present at high speed, inspect propeller shaft runout first.

1. With a dial indicator, measure propeller shaft runout at runout measuring points by rotating final drive companion flange with hands.

#### Limit

**Propeller shaft runout** : Refer to [DLN-128, "Propeller Shaft Runout"](#).

2. If runout still exceeds specifications, separate propeller shaft at final drive companion flange, then rotate companion flange 60, 120, 180, 240, 300 degrees and install propeller shaft.
3. Check runout again. If runout still exceeds specifications, replace propeller shaft assembly.
4. Check the vibration by driving vehicle.

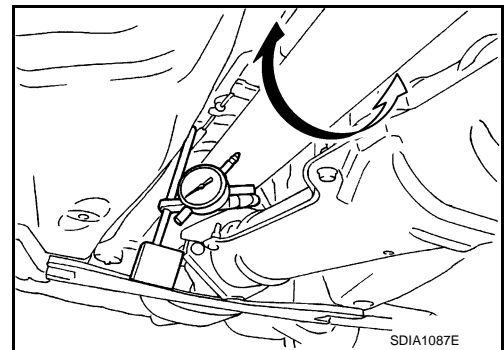

### RUNOUT MEASURING POINT



# CHASSIS MAINTENANCE

## < PERIODIC MAINTENANCE >

Propeller shaft runout measuring point (Point "△").

↔: Vehicle front

### Standard

<b>A</b>	<b>: 162 mm (6.38 in)</b>
<b>B</b>	<b>: 245 mm (9.65 in)</b>
<b>C</b>	<b>: 185 mm (7.28 in)</b>

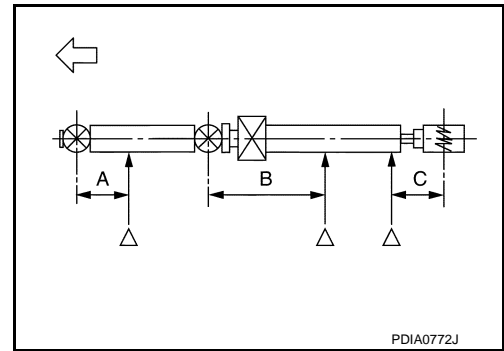

REAR PROPELLER SHAFT: 3F-R-2VL107

REAR PROPELLER SHAFT: 3F-R-2VL107 : Inspection

INFOID:000000004001433

### NOISE

- Check the propeller shaft tube surface for dents or cracks. If damaged, replace propeller shaft assembly.
- If center bearing is noisy or damaged, replace propeller shaft assembly.

### VIBRATION

If vibration is present at high speed, inspect propeller shaft runout first.

1. With a dial indicator, measure propeller shaft runout at runout measuring points by rotating final drive companion flange with hands.

### Limit

**Propeller shaft runout** : Refer to [DLN-137. "Propeller Shaft Runout"](#).

2. If runout still exceeds specifications, separate propeller shaft at final drive companion flange, then rotate companion flange 60, 120, 180, 240, 300 degrees and install propeller shaft.
3. Check runout again. If runout still exceeds specifications, replace propeller shaft assembly.
4. Check the vibration by driving vehicle.

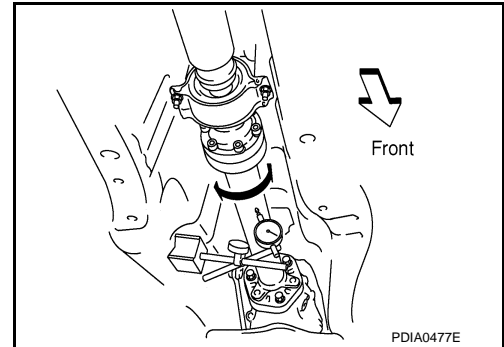

### RUNOUT MEASURING POINT

Propeller shaft runout measuring point (Point "△").

↔: Vehicle front

### Standard

<b>A</b>	<b>: 162 mm (6.38 in)</b>
<b>B</b>	<b>: 270 mm (10.63 in)</b>
<b>C</b>	<b>: 185 mm (7.28 in)</b>

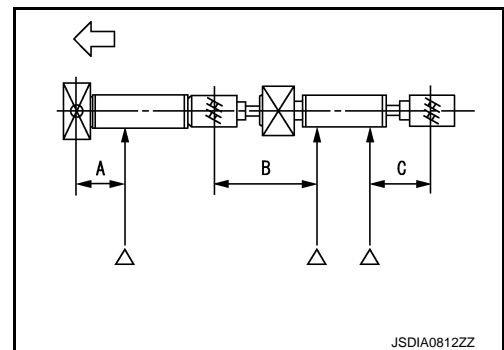

FRONT DIFFERENTIAL GEAR OIL: F160A

FRONT DIFFERENTIAL GEAR OIL: F160A : Inspection

INFOID:000000004001718

### OIL LEAKAGE

Make sure that oil is not leaking from final drive assembly or around it.

### OIL LEVEL

A  
B  
C  
D  
E  
F  
G  
H  
I  
J  
K  
L  
M  
N  
O

MA

# CHASSIS MAINTENANCE

## < PERIODIC MAINTENANCE >

- Remove filler plug (1) and check oil level from filler plug mounting hole as shown in the figure.

**CAUTION:**

**Never start engine while checking oil level.**

- Set a gasket on filler plug (1) and install it on final drive assembly. Refer to [DLN-151, "Exploded View"](#).

**CAUTION:**

**Never reuse gasket.**

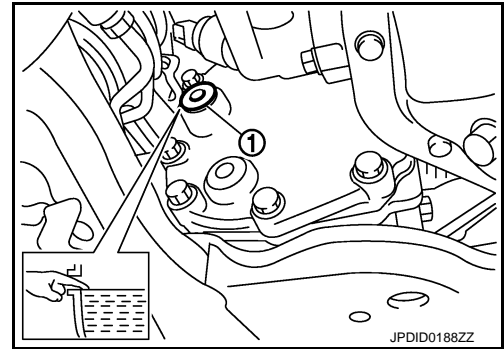

## FRONT DIFFERENTIAL GEAR OIL: F160A : Draining

INFOID:000000004001719

- Stop engine.
- Remove drain plug (1) and drain gear oil.
- Set a gasket on drain plug (1) and install it to final drive assembly and tighten to the specified torque. Refer to [DLN-151, "Exploded View"](#).

**CAUTION:**

**Never reuse gasket.**

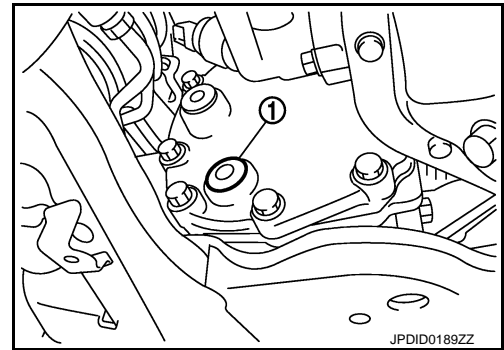

## FRONT DIFFERENTIAL GEAR OIL: F160A : Refilling

INFOID:000000004001720

- Remove filler plug (1). Fill with new gear oil until oil level reaches the specified level near filler plug mounting hole.

**Oil grade and Viscosity** : Refer to [MA-12, "Fluids and Lubricants"](#).

**Oil capacity** : Refer to [DLN-180, "General Specifications"](#).

- After refilling oil, check oil level. Set a gasket to filler plug (1), then install it to final drive assembly. Refer to [DLN-151, "Exploded View"](#).

**CAUTION:**

**Never reuse gasket.**

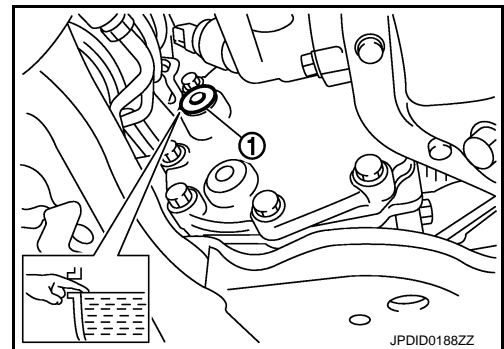

## REAR DIFFERENTIAL GEAR OIL: R200

## REAR DIFFERENTIAL GEAR OIL: R200 : Inspection

INFOID:000000004001721

### OIL LEAKAGE

- Make sure that oil is not leaking from final drive assembly or around it.

### OIL LEVEL

# CHASSIS MAINTENANCE

## < PERIODIC MAINTENANCE >

- Remove filler plug (1) and check oil level from filler plug mounting hole as shown in the figure.

**CAUTION:**

**Never start engine while checking oil level.**

- Set a gasket on filler plug (1) and install it on final drive assembly. Refer to [DLN-210, "2WD : Exploded View"](#) (2WD), [DLN-223, "AWD : Exploded View"](#) (AWD).

**CAUTION:**

**Never reuse gasket.**

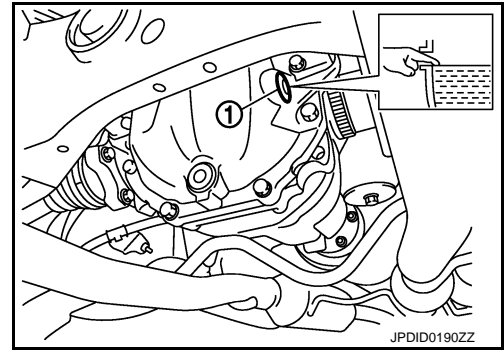

INFOID:000000004001722

## REAR DIFFERENTIAL GEAR OIL: R200 : Draining

- Stop engine.
- Remove drain plug (1) and drain gear oil.
- Set a gasket on drain plug (1) and install it to final drive assembly and tighten to the specified torque. Refer to [DLN-210, "2WD : Exploded View"](#) (2WD), [DLN-223, "AWD : Exploded View"](#) (AWD).

**CAUTION:**

**Never reuse gasket.**

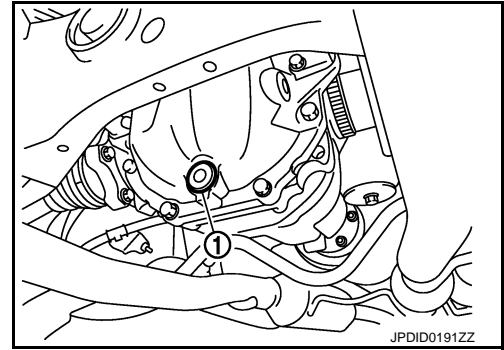

INFOID:000000004001723

## REAR DIFFERENTIAL GEAR OIL: R200 : Refilling

- Remove filler plug (1). Fill with new gear oil until oil level reaches the specified level near filler plug mounting hole.

**Oil grade and viscosity** : Refer to [MA-12, "Fluids and Lubricants"](#).

**Oil capacity** : Refer to [DLN-254, "General Specification"](#).

- After refilling oil, check oil level. Set a gasket to filler plug (1), then install it to final drive assembly. Refer to [DLN-210, "2WD : Exploded View"](#) (2WD), [DLN-223, "AWD : Exploded View"](#) (AWD).

**CAUTION:**

**Never reuse gasket.**

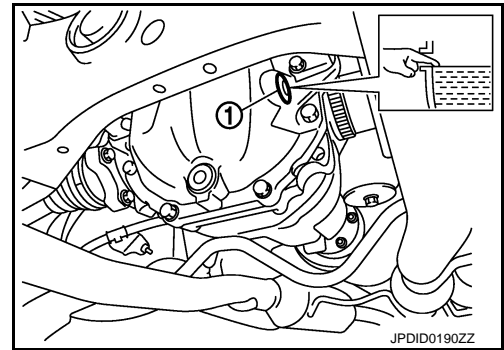

INFOID:000000004001728

## REAR DIFFERENTIAL GEAR OIL: R230

## REAR DIFFERENTIAL GEAR OIL: R230 : Inspection

### OIL LEAKAGE

Make sure that differential gear oil is not leaking from the rear final drive assembly or around it.

### OIL LEVEL

A  
B  
C  
D  
E  
F  
G  
H  
I  
J  
K  
L  
M  
N  
O

MA

# CHASSIS MAINTENANCE

## < PERIODIC MAINTENANCE >

1. Check the differential gear oil level from the filler plug hole as shown.  
**CAUTION:**  
**Never start engine while checking differential gear oil level.**
2. Install the filler plug with a new gasket on it to the rear final drive assembly. Tighten to the specified torque. Refer to [DLN-273, "Exploded View"](#).  
**CAUTION:**  
**Never reuse gasket.**

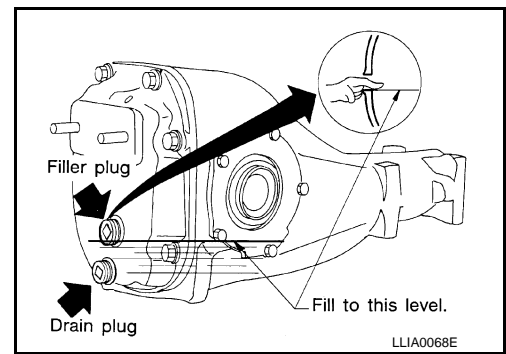

## REAR DIFFERENTIAL GEAR OIL: R230 : Draining

INFOID:000000004001729

1. Stop the engine.
2. Remove the drain plug and gasket from the rear final drive assembly to drain the differential gear oil.
3. Install the drain plug with a new gasket to the rear final drive assembly. Tighten to the specified torque. Refer to [DLN-273, "Exploded View"](#).  
**CAUTION:**  
**Never reuse gasket.**

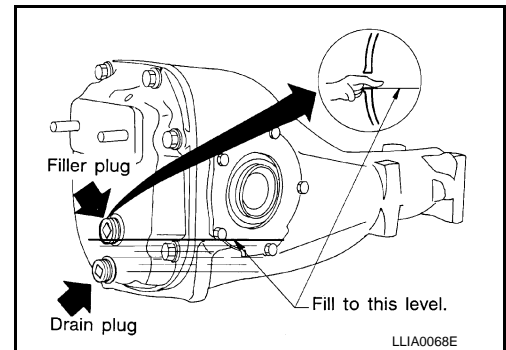

## REAR DIFFERENTIAL GEAR OIL: R230 : Refilling

INFOID:000000004001730

1. Remove the filler plug and gasket from the rear final drive assembly.
2. Fill the rear final drive assembly with new differential gear oil until the level reaches the specified level near the filler plug hole.

**Oil grade and viscosity** : Refer to [MA-12, "Fluids and Lubricants"](#).

**Oil capacity** : Refer to [DLN-292, "General Specification"](#).

3. Install the filler plug with a new gasket on it to the rear final drive assembly. Tighten to the specified torque. Refer to [DLN-273, "Exploded View"](#).  
**CAUTION:**  
**Never reuse gasket.**

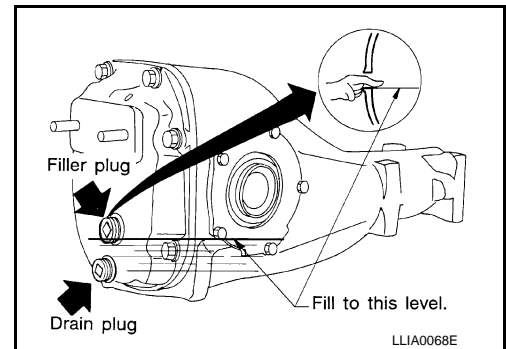

## WHEELS (BONDING WEIGHT TYPE)

### WHEELS (BONDING WEIGHT TYPE) : Adjustment

INFOID:000000004158716

#### BALANCING WHEELS (BONDING WEIGHT TYPE)

##### Preparation Before Adjustment

Using releasing agent, remove double-faced adhesive tape from the road wheel.

##### **CAUTION:**

- Be careful not to scratch the road wheel during removal.
- After removing double-faced adhesive tape, wipe clean traces of releasing agent from the road wheel.

##### Wheel Balance Adjustment

If a tire balance machine has adhesion balance weight mode settings and drive-in weight mode setting, select and adjust a drive-in weight mode suitable for road wheels.

# CHASSIS MAINTENANCE

## < PERIODIC MAINTENANCE >

1. Set road wheel on tire balance machine using the center hole as a guide. Start the tire balance machine.
2. When inner and outer unbalance values are shown on the tire balance machine indicator, multiply outer unbalance value by 5/3 to determine balance weight that should be used. Select the outer balance weight with a value closest to the calculated value above and install to the designated outer position of, or at the designated angle in relation to the road wheel.

**CAUTION:**

- Never install the inner balance weight before installing the outer balance weight.
- Before installing the balance weight, always to clean the mating surface of the road wheel.

- a. Indicated unbalance value  $\times 5/3 =$  balance weight to be installed  
**Calculation example:**  
 $23 \text{ g (0.81 oz)} \times 5/3 = 38.33 \text{ g (1.35 oz)} \Rightarrow 37.5 \text{ g (1.32 oz)}$  balance weight (closer to calculated balance weight value)

**NOTE:**

Note that balance weight value must be closer to the calculated balance weight value.

**Example:**

36.2  $\Rightarrow$  35 g (1.23 oz)

36.3  $\Rightarrow$  37.5 g (1.32 oz)

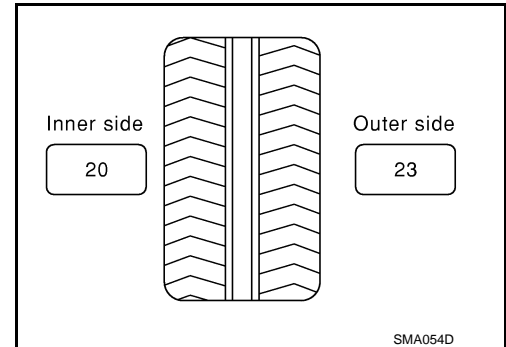

- b. Installed balance weight in the position.
  - When installing balance weight (1) to road wheels, set it into the grooved area (A) on the inner wall of the road wheel as shown in the figure so that the balance weight center (B) is aligned with the tire balance machine indication position (angle) (C).

**CAUTION:**

- Always use genuine NISSAN adhesion balance weights.
- Balance weights are non-reusable; always replace with new ones.
- Never install more than three sheets of balance weight.

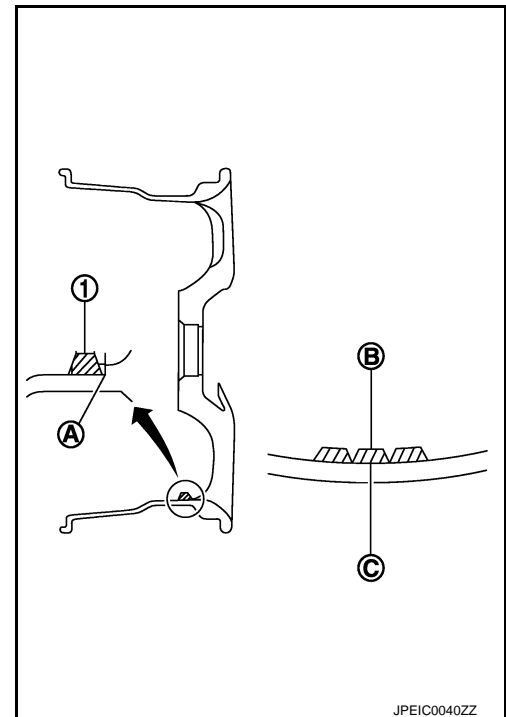

- c. If calculated balance weight value exceeds 50 g (1.76 oz), install two balance weight sheets in line with each other as shown in the figure.

**CAUTION:**

**Never install one balance weight sheet on top of another.**

3. Start the tire balance machine again.
4. Install drive-in balance weight on inner side of road wheel in the tire balance machine indication position (angle).

**CAUTION:**

**Never install more than two balance weight.**

5. Start the tire balance machine. Make sure that inner and outer residual unbalance values are 5 g (0.17 oz) each or below.
6. If either residual unbalance value exceeds 5 g (0.17 oz), repeat installation procedures.

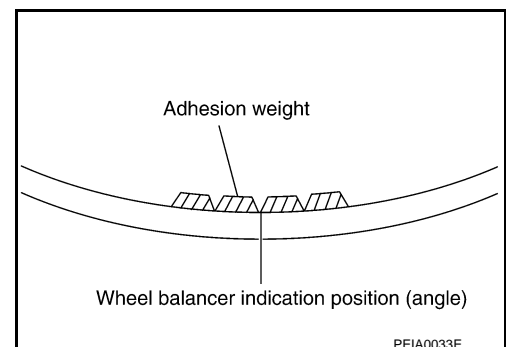

A  
B  
C  
D  
E  
F  
G  
H  
I  
J  
K  
L  
M  
N  
O  
MA

# CHASSIS MAINTENANCE

< PERIODIC MAINTENANCE >

## Limit

**Dynamic (At flange):** Refer to [WT-76, "Road Wheel"](#).

**Static (At flange):** Refer to [WT-76, "Road Wheel"](#).

## TIRE ROTATION

- Follow the maintenance schedule for tire rotation service intervals. Refer to [MA-5, "Explanation of General Maintenance"](#).
- When installing the wheel, tighten wheel nuts to the specified torque.

### CAUTION:

- Never include the T-type spare tire when rotating the tires.
- When installing wheels, tighten them diagonally by dividing the work two to three times in order to prevent the wheels from developing any distortion.
- Be careful not to tighten wheel nut at torque exceeding the criteria for preventing strain of disc rotor.
- Use NISSAN genuine wheel nuts for aluminum wheels.

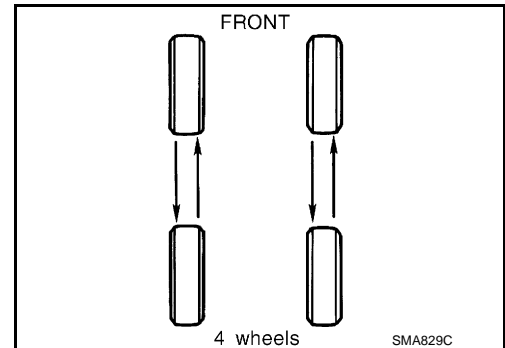

**Wheel nuts tightening torque** : Refer to [WT-76, "Road Wheel"](#).

- Perform the ID registration, after tire rotation. Refer to [WT-7, "ID REGISTRATION PROCEDURE : Transmitter ID Registration Procedure"](#).

## BRAKE FLUID LEVEL AND LEAKS

### BRAKE FLUID LEVEL AND LEAKS : Inspection

- If fluid level is extremely low, check brake system for leaks.

INFOID:000000004001331

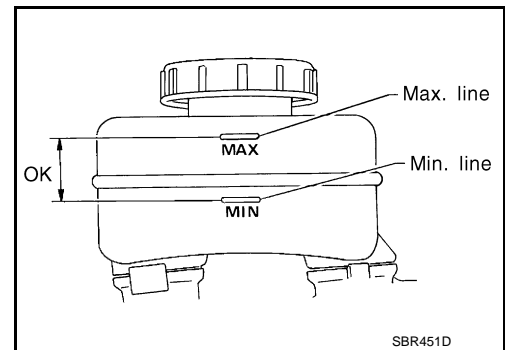

## BRAKE LINES AND CABLES

### BRAKE LINES AND CABLES : Inspection

- Check brake fluid lines and parking brake cables for improper attachment, leaks, chafing, abrasions, deterioration, etc.

INFOID:000000004001332

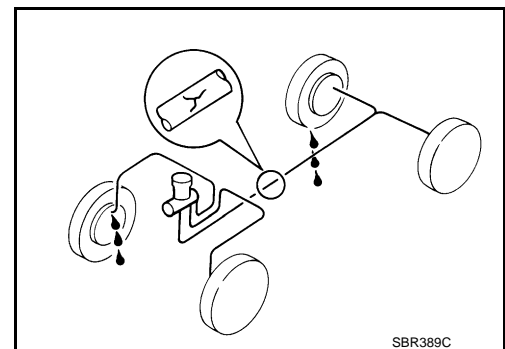

## BRAKE FLUID

# CHASSIS MAINTENANCE

< PERIODIC MAINTENANCE >

## BRAKE FLUID : Changing

INFOID:000000004001334

1. Drain brake fluid from each bleed valve.
2. Refill until new brake fluid comes out from each bleed valve. Use same procedure as in bleeding hydraulic system to refill brake fluid.  
Refer to [BR-11. "Bleeding Brake System"](#).
  - Refill with recommended Genuine NISSAN Super Heavy Duty Brake Fluid or equivalent DOT 3 (US FMVSS No. 116). Refer to [MA-12. "Fluids and Lubricants"](#).
  - Never reuse drained brake fluid.
  - Be careful not to splash brake fluid on painted areas.

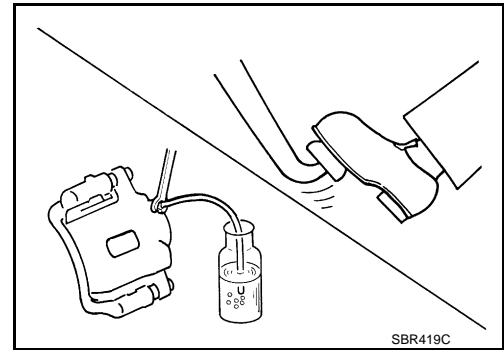

## DISC BRAKE

### DISC BRAKE : Inspection

INFOID:000000004001334

#### DISC ROTOR

Check condition, wear, and damage.

#### CALIPER

- Check for leakage.

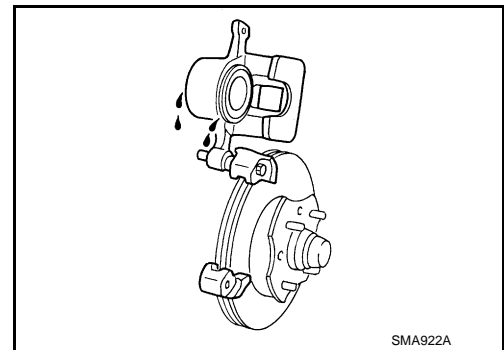

#### BRAKE PAD

- Check for wear or damage.

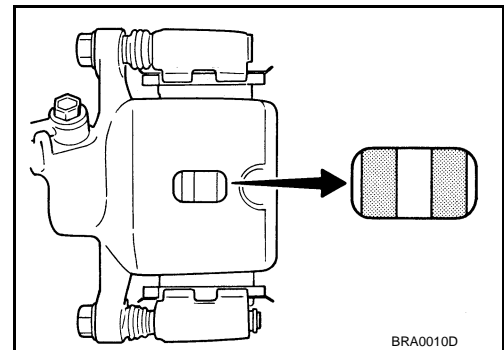

## DISC BRAKE : Front Disc Brake

INFOID:000000004001999

### 2 PISTON TYPE

Unit: mm (in)

Item		Limit
Brake pad	Wear thickness	2.0 (0.079)
	Wear thickness	32.0 (1.260)
Disc rotor	Thickness variation (measured at 8 positions)	0.015 (0.0006)
	Runout (with it attached to the vehicle)	0.035 (0.0014)

### 4 PISTON TYPE

A  
B  
C  
D  
E  
F  
G  
H  
I  
J  
K  
L  
M  
N  
O

MA

# CHASSIS MAINTENANCE

## < PERIODIC MAINTENANCE >

Unit: mm (in)

Item		Limit
Brake pad	Wear thickness	2.0 (0.079)
Disc rotor	Wear thickness	30.0 (1.181)
	Thickness variation (measured at 8 positions)	0.015 (0.0006)
	Runout (with it attached to the vehicle)	0.035 (0.0014)

## DISC BRAKE : Rear Disc Brake

INFOID:000000004002000

### 1 PISTON TYPE

Unit: mm (in)

Item		Limit
Brake pad	Wear thickness	2.0 (0.079)
Disc rotor	Wear thickness	14.0 (0.551)
	Thickness variation (measured at 8 positions)	0.015 (0.0006)
	Runout (with it attached to the vehicle)	0.055 (0.0022)

### 2 PISTON TYPE

Unit: mm (in)

Item		Limit
Brake pad	Wear thickness	2.0 (0.079)
Disc rotor	Wear thickness	18.0 (0.709)
	Thickness variation (measured at 8 positions)	0.015 (0.0006)
	Runout (with it attached to the vehicle)	0.055 (0.0022)

## STEERING GEAR AND LINKAGE

### STEERING GEAR AND LINKAGE : Inspection

INFOID:000000004001337

#### STEERING GEAR

- Check gear housing and boots for looseness, damage and grease leakage.
- Check connection with steering column for looseness.

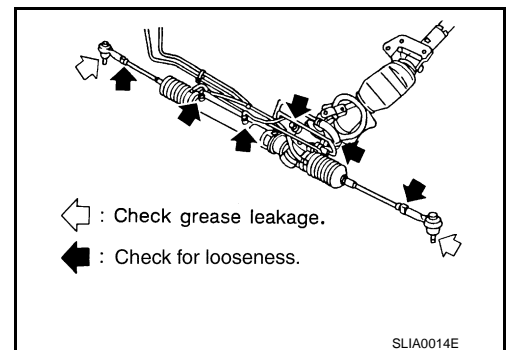

#### STEERING LINKAGE

Check ball joint, dust cover and other component parts for looseness, wear, damage and grease leakage.

#### POWER STEERING FLUID AND LINES



# CHASSIS MAINTENANCE

< PERIODIC MAINTENANCE >

## POWER STEERING FLUID AND LINES : Inspection

INFOID:000000004001338

Check fluid level in reservoir tank with engine off.

Use "HOT" range at fluid temperatures of 50 to 80°C (122 to 176°F) or "COLD" range at fluid temperatures of 0 to 30°C (32 to 86°F).

### CAUTION:

- Do not overfill.
- Recommended fluid is Genuine NISSAN PSF or equivalent. Refer to [MA-12. "Fluids and Lubricants"](#).

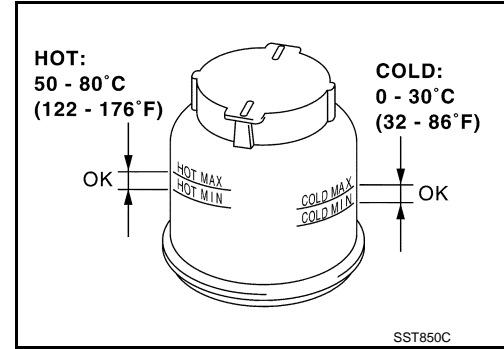

- Check lines for improper attachment, leaks, cracks, damage, loose connections, chafing and deterioration.
- Check rack boots for accumulation of power steering fluid.

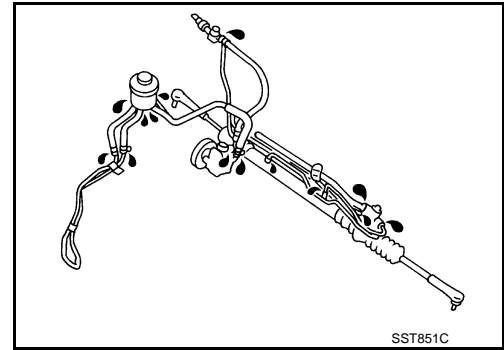

## AXLE AND SUSPENSION PARTS

### AXLE AND SUSPENSION PARTS : Inspection

INFOID:000000004001339

Check front and rear axle and suspension parts for excessive play, cracks, wear or other damage.

- Shake each wheel to check for excessive play.
- Check wheel bearings for smooth operation.
- Check axle and suspension nuts and bolts for looseness.
- Check strut (shock absorber) for oil leakage or other damage.
- Check suspension ball joint for grease leakage and ball joint dust cover for cracks or other damage.

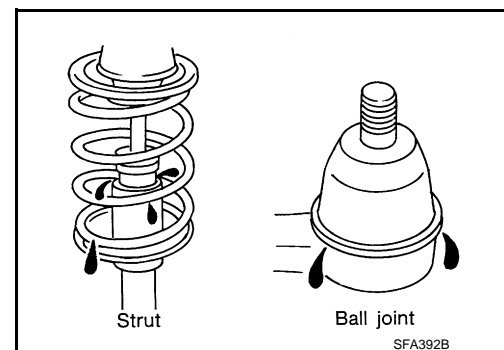
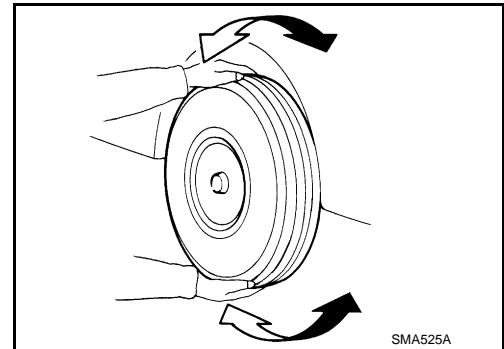

## DRIVE SHAFT

A  
B  
C  
D  
E  
F  
G  
H  
I  
J  
K  
L  
M  
N  
O

MA

# CHASSIS MAINTENANCE

< PERIODIC MAINTENANCE >

## DRIVE SHAFT : Inspection

INFOID:000000004001340

Check boot and drive shaft for cracks, wear, damage and grease leakage.

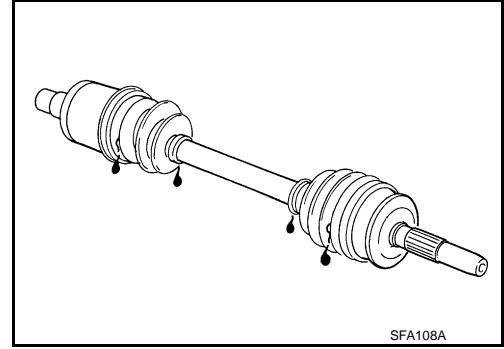

# BODY MAINTENANCE

< PERIODIC MAINTENANCE >

## BODY MAINTENANCE

### LOCKS, HINGES AND HOOD LATCH

#### LOCKS, HINGES AND HOOD LATCH : Lubricating

INFOID:000000004001341

For hood and hood lock illustration.

- Hood: Refer to [DLK-225, "HOOD ASSEMBLY : Exploded View"](#).
- Hood lock: Refer to [DLK-256, "Exploded View"](#).

For door and door lock illustration.

- Front door: Refer to [DLK-236, "DOOR ASSEMBLY : Exploded View"](#).
- Front door lock: Refer to [DLK-258, "DOOR LOCK : Exploded View"](#).
- Rear door: Refer to [DLK-242, "DOOR ASSEMBLY : Exploded View"](#).
- Rear door lock: Refer to [DLK-262, "DOOR LOCK : Exploded View"](#).

For back door and back door lock illustration.

- Back door: Refer to [DLK-248, "BACK DOOR ASSEMBLY : Exploded View"](#).
- Back door lock: Refer to [DLK-266, "Exploded View"](#).

### SEAT BELT, BUCKLES, RETRACTORS, ANCHORS AND ADJUSTERS

#### SEAT BELT, BUCKLES, RETRACTORS, ANCHORS AND ADJUSTERS : Inspection

INFOID:000000004001342

For front seat belt illustration. Refer to [SB-6, "SEAT BELT RETRACTOR : Exploded View"](#).

For rear seat belt illustration. Refer to [SB-11, "SEAT BELT RETRACTOR : Exploded View"](#).

#### **CAUTION:**

- **After any collision, inspect all seat belt assemblies, including retractors and other attached hardwares (I.e. anchor bolt, guide rail set). Nissan recommends to replace all seat belt assemblies in use during a collision, unless not damaged and properly operating after minor collision.**

**Also inspect seat belt assemblies not in use during a collision, and replace if damaged or improperly operating.**

**Seat belt pre-tensioner should be replaced even if the seat belts are not in use during a frontal collision where the driver and passenger air bags are deployed.**

- **If any component of seat belt assembly is questionable, do not repair.**

**Replace as seat belt assembly.**

- **If webbing is cut, frayed, or damaged, replace belt assembly.**
- **Never oil tongue and buckle.**
- **Use a genuine NISSAN seat belt assembly.**

For details, refer to [SB-4, "SEAT BELT RETRACTOR : Inspection"](#), [SB-9, "SEAT BELT RETRACTOR : Inspection"](#) in SB section.

- Check anchors for loose mounting
- Check belts for damage
- Check retractor for smooth operation
- Check function of buckles and tongues when buckled and released

A  
B  
C  
D  
E  
F  
G  
H  
I  
J  
K  
L  
M  
N  
O

MA

# SERVICE DATA AND SPECIFICATIONS (SDS)

< SERVICE DATA AND SPECIFICATIONS (SDS)

## SERVICE DATA AND SPECIFICATIONS (SDS)

### SERVICE DATA AND SPECIFICATIONS (SDS)

#### DRIVE BELT (VQ35HR)

DRIVE BELT (VQ35HR) : Drive Belt

INFOID:000000004159013

#### DRIVE BELT

Tension of drive belt	Belt tension is not necessary, as it is automatically adjusted by drive belt auto-tensioner.
-----------------------	--

#### DRIVE BELTS (VK50VE)

DRIVE BELTS (VK50VE) : Drive Belts

INFOID:000000004002012

#### DRIVE BELT

Tension of drive belts	Belt tension is not necessary, as it is automatically adjusted by drive belt auto-tensioner.
------------------------	--

#### ENGINE COOLANT (VQ35HR)

ENGINE COOLANT (VQ35HR) : Periodical Maintenance Specification

INFOID:000000004002027

#### ENGINE COOLANT CAPACITY (APPROXIMATELY)

Unit: ℓ (US qt, Imp qt)

Engine coolant capacity [With reservoir tank ("MAX" level)]	9.2 (9-3/4, 8-1/8)
Reservoir tank engine coolant capacity (At "MAX" level)	0.8 (7/8, 3/4)

#### ENGINE COOLANT (VK50VE)

ENGINE COOLANT (VK50VE) : Periodical Maintenance Specification

INFOID:000000004002028

#### ENGINE COOLANT CAPACITY (APPROXIMATELY)

Unit: ℓ (US qt, Imp qt)

Engine coolant capacity [With reservoir tank ("MAX" level)]	11 (11-5/8, 9-5/8)
Reservoir tank engine coolant capacity (At "MAX" level)	0.8 (7/8, 3/4)

#### ENGINE OIL (VQ35HR)

ENGINE OIL (VQ35HR) : Periodical Maintenance Specification

INFOID:000000004002025

#### ENGINE OIL CAPACITY (APPROXIMATELY)

Unit: ℓ (US qt, Imp qt)

Drain and refill	With oil filter change	4.9 (5-1/8, 4-1/4)
	Without oil filter change	4.6 (4-7/8, 4)
Dry engine (Overhaul)		5.7 (6, 5)

#### ENGINE OIL (VK50VE)

ENGINE OIL (VK50VE) : Periodical Maintenance Specification

INFOID:000000004002026

#### ENGINE OIL CAPACITY (APPROXIMATELY)

# SERVICE DATA AND SPECIFICATIONS (SDS)

## < SERVICE DATA AND SPECIFICATIONS (SDS)

Unit: ℓ (US qt, Imp qt)

Drain and refill	With oil filter change	6.7 (7-1/8, 5-7/8)
	Without oil filter change	5.8 (6-1/8, 5-1/8)
Dry engine (Overhaul)		7.2 (7-5/8, 6-3/8)

### SPARK PLUG (VQ35HR)

SPARK PLUG (VQ35HR) : Spark Plug

INFOID:0000000004159014

SPARK PLUG

Unit: mm (in)

Make		DENSO
Standard type		FXE22HR11
Gap	Standard	1.1 (0.043)
	Limit	1.4 (0.055)

### SPARK PLUG (VK50VE)

SPARK PLUG (VK50VE) : Spark Plug

INFOID:0000000004002017

SPARK PLUG

Unit: mm (in)

Make		DENSO
Standard type		FXE22HR11
Gap	Standard	1.1 (0.043)
	Limit	1.4 (0.055)

### ROAD WHEEL

ROAD WHEEL : Road Wheel

INFOID:0000000004002029

ALUMINUM WHEEL

Item		Limit
Radial runout	Lateral deflection	Less than 0.3 mm (0.012 in)
	Vertical deflection	
Allowable unbalance	Dynamic (At flange)	Less than 5 g (0.17 oz) (one side)
	Static (At flange)	Less than 10 g (0.35 oz)

A  
B  
C  
D  
E  
F  
G  
H  
I  
J  
K  
L  
M  
N  
O

MA