

A
EM
C
D
E
F
G
H
I
J
K
L
M
N
O
P

SECTION **EM**

ENGINE MECHANICAL

CONTENTS

<p style="text-align: center;">VQ35HR</p> <p>SYMPTOM DIAGNOSIS 5</p> <p>NOISE, VIBRATION AND HARSHNESS (NVH) TROUBLESHOOTING 5</p> <p style="padding-left: 20px;">NVH Troubleshooting - Engine Noise5</p> <p style="padding-left: 20px;">Use the Chart Below to Help You Find the Cause of the Symptom5</p> <p>PRECAUTION 7</p> <p>PRECAUTIONS 7</p> <p style="padding-left: 20px;">Precaution for Procedure without Cowl Top Cover.....7</p> <p style="padding-left: 20px;">Precaution for Supplemental Restraint System (SRS) "AIR BAG" and "SEAT BELT PRE-TENSIONER"7</p> <p style="padding-left: 20px;">Precaution Necessary for Steering Wheel Rotation after Battery Disconnect7</p> <p style="padding-left: 20px;">Draining Engine Coolant8</p> <p style="padding-left: 20px;">Disconnecting Fuel Piping8</p> <p style="padding-left: 20px;">Removal and Disassembly8</p> <p style="padding-left: 20px;">Inspection, Repair and Replacement8</p> <p style="padding-left: 20px;">Assembly and Installation8</p> <p style="padding-left: 20px;">Parts Requiring Angle Tightening9</p> <p style="padding-left: 20px;">Liquid Gasket9</p> <p style="padding-left: 20px;">Definitions of Bank Names 10</p> <p>PREPARATION 11</p> <p>PREPARATION 11</p> <p style="padding-left: 20px;">Special Service Tools 11</p> <p style="padding-left: 20px;">Commercial Service Tools 12</p> <p>PERIODIC MAINTENANCE 15</p> <p>DRIVE BELT 15</p> <p style="padding-left: 20px;">Exploded View 15</p> <p style="padding-left: 20px;">Checking 15</p> <p style="padding-left: 20px;">Tension Adjustment 15</p> <p style="padding-left: 20px;">Removal and Installation 15</p> <p style="padding-left: 20px;">Inspection 16</p>	<p>AIR CLEANER FILTER 17</p> <p style="padding-left: 20px;">Removal and Installation 17</p> <p>SPARK PLUG 18</p> <p style="padding-left: 20px;">Exploded View 18</p> <p style="padding-left: 20px;">Removal and Installation 18</p> <p style="padding-left: 20px;">Inspection 19</p> <p>CAMSHAFT VALVE CLEARANCE 20</p> <p style="padding-left: 20px;">Inspection and Adjustment 20</p> <p>COMPRESSION PRESSURE 25</p> <p style="padding-left: 20px;">Inspection 25</p> <p>REMOVAL AND INSTALLATION 27</p> <p>ENGINE COVER 27</p> <p style="padding-left: 20px;">Exploded View 27</p> <p style="padding-left: 20px;">Removal and Installation 27</p> <p>DRIVE BELT AUTO TENSIONER AND IDLER PULLEY 28</p> <p style="padding-left: 20px;">Exploded View 28</p> <p style="padding-left: 20px;">Removal and Installation 28</p> <p>AIR CLEANER AND AIR DUCT 29</p> <p style="padding-left: 20px;">Exploded View 29</p> <p style="padding-left: 20px;">Removal and Installation 29</p> <p style="padding-left: 20px;">Inspection 30</p> <p>INTAKE MANIFOLD COLLECTOR 31</p> <p style="padding-left: 20px;">Exploded View 31</p> <p style="padding-left: 20px;">Removal and Installation 31</p> <p>INTAKE MANIFOLD 34</p> <p style="padding-left: 20px;">Exploded View 34</p> <p style="padding-left: 20px;">Removal and Installation 34</p> <p style="padding-left: 20px;">Inspection 35</p> <p>EXHAUST MANIFOLD 36</p> <p style="padding-left: 20px;">Exploded View 36</p> <p style="padding-left: 20px;">Removal and Installation 36</p> <p style="padding-left: 20px;">Inspection 38</p>
--	--

FUEL INJECTOR AND FUEL TUBE	40	OIL PAN (UPPER)	100
Exploded View	40	2WD	100
Removal and Installation	40	2WD : Exploded View	100
Inspection	45	2WD : Disassembly and Assembly	100
OIL PAN (LOWER) AND OIL STRAINER	46	2WD : Inspection	102
Exploded View	46	AWD	102
Removal and Installation	47	AWD : Exploded View	103
Inspection	49	AWD : Disassembly and Assembly	103
IGNITION COIL, SPARK PLUG AND ROCK- ER COVER	50	AWD : Inspection	106
Exploded View	50	CYLINDER HEAD	107
Removal and Installation	50	Exploded View	107
TIMING CHAIN	53	Disassembly and Assembly	107
Exploded View	53	Inspection	114
Removal and Installation	54	CYLINDER BLOCK	117
Inspection	68	Exploded View	117
CAMSHAFT	70	Disassembly and Assembly	118
Exploded View	70	Inspection	126
Removal and Installation	70	HOW TO SELECT PISTON AND BEARING ..	136
Inspection	74	Description	136
OIL SEAL	79	Piston	136
VALVE OIL SEAL	79	Connecting Rod Bearing	137
VALVE OIL SEAL : Removal and Installation	79	Main Bearing	139
FRONT OIL SEAL	79	SERVICE DATA AND SPECIFICATIONS (SDS)	142
FRONT OIL SEAL : Removal and Installation	79	SERVICE DATA AND SPECIFICATIONS (SDS)	142
REAR OIL SEAL	80	General Specification	142
REAR OIL SEAL : Removal and Installation	80	Drive Belt	142
UNIT REMOVAL AND INSTALLATION	82	Spark Plug	143
ENGINE ASSEMBLY	82	Intake Manifold	143
2WD	82	Exhaust Manifold	143
2WD : Exploded View	82	Camshaft	143
2WD : Removal and Installation	82	Cylinder Head	145
2WD : Inspection	86	Cylinder Block	147
AWD	86	Main Bearing	151
AWD : Exploded View	87	Connecting Rod Bearing	152
AWD : Removal and Installation	87	VK50VE	
AWD : Inspection	91	SYMPTOM DIAGNOSIS	153
UNIT DISASSEMBLY AND ASSEMBLY ...	92	NOISE, VIBRATION AND HARSHNESS (NVH) TROUBLESHOOTING	153
ENGINE STAND SETTING	92	NVH Troubleshooting - Engine Noise	153
Setting	92	Use the Chart Below to Help You Find the C ause of the Symptom	153
ENGINE UNIT	94	PRECAUTION	155
Disassembly	94	PRECAUTIONS	155
Assembly	94	Precaution for Procedure without Cowl Top Cover. 155	
REAR TIMING CHAIN CASE	95	Precaution for Supplemental Restraint System (SRS) "AIR BAG" and "SEAT BELT PRE-TEN- SIONER"	155
Exploded View	95		
Disassembly	96		
Assembly	97		

Precaution Necessary for Steering Wheel Rotation after Battery Disconnect	155	FUEL INJECTOR AND FUEL TUBE	182	A
Precaution for Drain Engine Coolant and Engine Oil	156	Exploded View	182	
Precaution for Disconnecting Fuel Piping	156	Removal and Installation	182	
Precaution for Removal and Disassembly	156	Inspection	187	
Precaution for Inspection, Repair and Replacement	156	OIL PAN (LOWER) AND OIL STRAINER	188	EM
Precaution for Assembly and Installation	156	Exploded View	188	
Parts Requiring Angle Tightening	157	Removal and Installation	189	C
Precaution for Liquid Gasket	157	Inspection	190	
Definitions of Bank Names	158	IGNITION COIL, SPARK PLUG AND ROCKER COVER	191	D
PREPARATION	159	Exploded View	191	
PREPARATION	159	Removal and Installation	191	
Special Service Tool	159	OIL SEAL	194	E
Commercial Service Tool	160	FRONT OIL SEAL	194	
PERIODIC MAINTENANCE	163	FRONT OIL SEAL : Removal and Installation	194	F
DRIVE BELTS	163	REAR OIL SEAL	194	
Exploded View	163	REAR OIL SEAL : Removal and Installation	195	G
Checking	163	UNIT REMOVAL AND INSTALLATION ...	196	
Tension Adjustment	164	ENGINE ASSEMBLY	196	H
Removal and Installation	164	Exploded View	196	
Inspection	164	Removal and Installation	196	
AIR CLEANER FILTER	166	Inspection	200	I
Removal and Installation	166	UNIT DISASSEMBLY AND ASSEMBLY .	202	
SPARK PLUG	167	ENGINE STAND SETTING	202	J
Exploded View	167	Setting	202	
Removal and Installation	167	ENGINE UNIT	204	K
Inspection	168	Disassembly	204	
CAMSHAFT VALVE CLEARANCE	169	Assembly	204	
Inspection	169	EXHAUST MANIFOLD AND THREE WAY CATALYST	205	L
COMPRESSION PRESSURE	173	Exploded View	205	
Inspection	173	Disassembly and Assembly	205	
REMOVAL AND INSTALLATION	174	Inspection	207	M
ENGINE ROOM COVER	174	OIL PAN (UPPER)	208	
Exploded View	174	Exploded View	208	N
Removal and Installation	175	Disassembly and Assembly	209	
DRIVE BELT AUTO TENSIONER AND IDLER PULLEY	176	Inspection	210	
Exploded View	176	TIMING CHAIN	212	O
Removal and Installation	176	Exploded View	212	
AIR CLEANER AND AIR DUCT	177	Disassembly and Assembly	213	
Exploded View	177	Inspection	225	P
Removal and Installation	177	CAMSHAFT	227	
Inspection	178	Exploded View	227	
INTAKE MANIFOLD	179	Disassembly and Assembly	228	
Exploded View	179	Inspection	236	
Removal and Installation	180	CYLINDER HEAD	245	
		Exploded View	245	

Disassembly and Assembly	246
Inspection	251
CYLINDER BLOCK	255
Exploded View	255
Disassembly and Assembly	256
Inspection	265
HOW TO SELECT PISTON AND BEARING ..	274
Description	274
Piston	274
Connecting Rod Bearing	275
Main Bearing	277

**SERVICE DATA AND SPECIFICATIONS
(SDS) 282**

SERVICE DATA AND SPECIFICATIONS (SDS)	282
General Specification	282
Drive Belts	282
Spark Plug	282
Exhaust Manifold	283
Camshaft	283
Cylinder Head	285
Cylinder Block	287
Main Bearing	291
Connecting Rod Bearing	292

SYMPTOM DIAGNOSIS

NOISE, VIBRATION AND HARSHNESS (NVH) TROUBLESHOOTING

NVH Troubleshooting - Engine Valve Noise

INFOID:000000003887309

A

EM

C

D

E

F

G

H

I

J

K

L

M

N

O

P

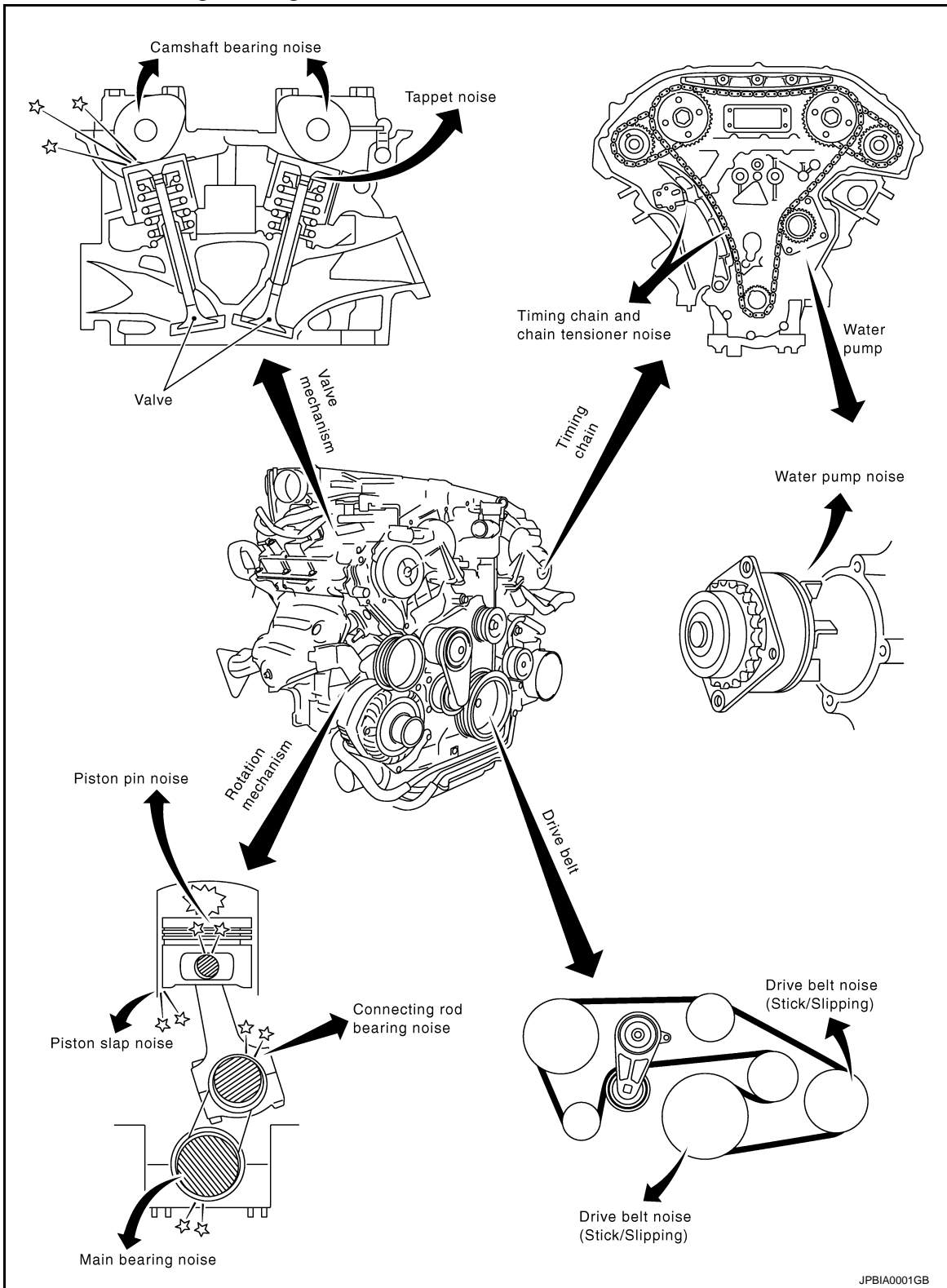

JPBIA0001GB

Use the Chart Below to Help You Find the Cause of the Symptom

INFOID:000000003887310

1. Locate the area where noise occurs.

NOISE, VIBRATION AND HARSHNESS (NVH) TROUBLESHOOTING

< SYMPTOM DIAGNOSIS >

[VQ35HR]

2. Confirm the type of noise.
3. Specify the operating condition of the engine.
4. Check specified noise source.

If necessary, repair or replace these parts.

Location of noise	Type of noise	Operating condition of engine						Source of noise	Check item	Reference page
		Before warm-up	After warm-up	When starting	When idling	When racing	While driving			
Top of engine Rocker cover Cylinder head	Ticking or clicking	C	A	—	A	B	—	Tappet noise	Valve clearance	EM-20
	Rattle	C	A	—	A	B	C	Camshaft bearing noise	Camshaft runout Camshaft journal oil clearance	EM-143
Crankshaft pulley Cylinder block (Side of engine) Oil pan	Slap or knock	—	A	—	B	B	—	Piston pin noise	Piston to piston pin oil clearance Connecting rod bushing oil clearance	EM-147
	Slap or rap	A	—	—	B	B	A	Piston slap noise	Piston to cylinder bore clearance Piston ring side clearance Piston ring end gap Connecting rod bend and torsion	EM-147
	Knock	A	B	C	B	B	B	Connecting rod bearing noise	Connecting rod bushing oil clearance Connecting rod bearing oil clearance	EM-147 EM-152
	Knock	A	B	—	A	B	C	Main bearing noise	Main bearing oil clearance Crankshaft runout	EM-151 EM-147
Front of engine Timing chain case	Tapping or ticking	A	A	—	B	B	B	Timing chain and timing chain tensioner noise	Timing chain cracks and wears Timing chain tensioner operation	EM-68 EM-54
Front of engine	Squeaking or fizzing	A	B	—	B	—	C	Drive belt (Sticking or slipping)	Drive belt deflection	EM-15
	Creaking	A	B	A	B	A	B	Drive belt (Slipping)	Idler pulley bearing operation	
	Squall Creak	A	B	—	B	A	B	Water pump noise	Water pump operation	CO-19

A: Closely related B: Related C: Sometimes related —: Not related

PRECAUTION

PRECAUTIONS

Precaution for Procedure without Cowl Top Cover

INFOID:000000003887311

When performing the procedure after removing cowl top cover, cover the lower end of windshield with urethane, etc.

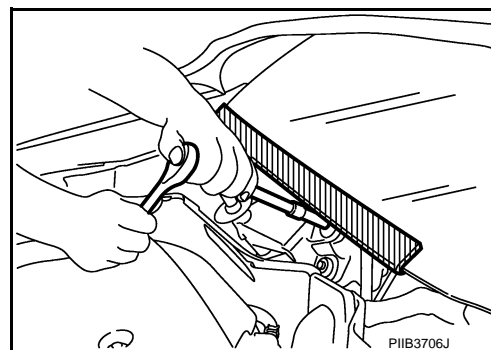

Precaution for Supplemental Restraint System (SRS) "AIR BAG" and "SEAT BELT PRE-TENSIONER"

INFOID:000000003887312

The Supplemental Restraint System such as "AIR BAG" and "SEAT BELT PRE-TENSIONER", used along with a front seat belt, helps to reduce the risk or severity of injury to the driver and front passenger for certain types of collision. This system includes seat belt switch inputs and dual stage front air bag modules. The SRS system uses the seat belt switches to determine the front air bag deployment, and may only deploy one front air bag, depending on the severity of a collision and whether the front occupants are belted or unbelted. Information necessary to service the system safely is included in the "SRS AIR BAG" and "SEAT BELT" of this Service Manual.

WARNING:

- To avoid rendering the SRS inoperative, which could increase the risk of personal injury or death in the event of a collision which would result in air bag inflation, all maintenance must be performed by an authorized NISSAN/INFINITI dealer.
- Improper maintenance, including incorrect removal and installation of the SRS, can lead to personal injury caused by unintentional activation of the system. For removal of Spiral Cable and Air Bag Module, see the "SRS AIR BAG".
- Do not use electrical test equipment on any circuit related to the SRS unless instructed to in this Service Manual. SRS wiring harnesses can be identified by yellow and/or orange harnesses or harness connectors.

PRECAUTIONS WHEN USING POWER TOOLS (AIR OR ELECTRIC) AND HAMMERS

WARNING:

- When working near the Air Bag Diagnosis Sensor Unit or other Air Bag System sensors with the ignition ON or engine running, DO NOT use air or electric power tools or strike near the sensor(s) with a hammer. Heavy vibration could activate the sensor(s) and deploy the air bag(s), possibly causing serious injury.
- When using air or electric power tools or hammers, always switch the ignition OFF, disconnect the battery, and wait at least 3 minutes before performing any service.

Precaution Necessary for Steering Wheel Rotation after Battery Disconnect

INFOID:000000003887313

NOTE:

- Before removing and installing any control units, first turn the push-button ignition switch to the LOCK position, then disconnect both battery cables.
- After finishing work, confirm that all control unit connectors are connected properly, then re-connect both battery cables.
- Always use CONSULT-III to perform self-diagnosis as a part of each function inspection after finishing work. If a DTC is detected, perform trouble diagnosis according to self-diagnosis results.

This vehicle is equipped with a push-button ignition switch and a steering lock unit. If the battery is disconnected or discharged, the steering wheel will lock and cannot be turned.

A
EM

C
D
E

F

G
H

I
J

K
L

M
N

O
P

PRECAUTIONS

[VQ35HR]

< PRECAUTION >

If turning the steering wheel is required with the battery disconnected or discharged, follow the procedure below before starting the repair operation.

OPERATION PROCEDURE

1. Connect both battery cables.

NOTE:

Supply power using jumper cables if battery is discharged.

2. Turn the push-button ignition switch to ACC position.
(At this time, the steering lock will be released.)
3. Disconnect both battery cables. The steering lock will remain released with both battery cables disconnected and the steering wheel can be turned.
4. Perform the necessary repair operation.
5. When the repair work is completed, re-connect both battery cables. With the brake pedal released, turn the push-button ignition switch from ACC position to ON position, then to LOCK position. (The steering wheel will lock when the push-button ignition switch is turned to LOCK position.)
6. Perform self-diagnosis check of all control units using CONSULT-III.

Draining Engine Coolant

INFOID:000000003887314

Drain engine coolant and engine oil when the engine is cooled.

Disconnecting Fuel Piping

INFOID:000000003887315

- Before starting work, check that no fire or spark producing items are in the work area.
- Release fuel pressure before disconnecting and disassembly.
- After disconnecting pipes, plug openings to stop fuel leakage.

Removal and Disassembly

INFOID:000000003887316

- When instructed to use SST, use specified tools. Always be careful to work safely, avoid forceful or uninstructed operations.
- Exercise maximum care to avoid damage to mating or sliding surfaces.
- Dowel pins are used for several parts alignment. When replacing and reassembling parts with dowel pins, check that dowel pins are installed in the original position.
- Cover openings of engine system with a tape or equivalent, if necessary, to seal out foreign materials.
- Mark and arrange disassembly parts in an organized way for easy troubleshooting and re-assembly.
- When loosening nuts and bolts, as a basic rule, start with the one furthest outside, then the one diagonally opposite, and so on. If the order of loosening is specified, do exactly as specified. Power tools may be used in the step.

Inspection, Repair and Replacement

INFOID:000000003887317

Before repairing or replacing, thoroughly inspect parts. Inspect new replacement parts in the same way, and replace if necessary.

Assembly and Installation

INFOID:000000003887318

- Use torque wrench to tighten bolts or nuts to specification.
- When tightening bolts and nuts, as a basic rule, equally tighten in several different steps starting with the ones in center, then ones on inside and outside diagonally in this order. If the order of tightening is specified, do exactly as specified.
- Replace with new gasket, packing, oil seal or O-ring.
- Dowel pins are used for several parts alignment. When replacing and reassembling parts with dowel pins, check that dowel pins are installed in the original position.
- Thoroughly wash, clean, and air-blow each part. Carefully check engine oil or engine coolant passages for any restriction and blockage.
- Avoid damaging sliding or mating surfaces. Completely remove foreign materials such as cloth lint or dust. Before assembly, oil sliding surfaces well.
- Release air within route when refilling after draining engine coolant.
- After repairing, start the engine and increase engine speed to check engine coolant, fuel, engine oil, and exhaust gases for leakage.

PRECAUTIONS

[VQ35HR]

< PRECAUTION >

Parts Requiring Angle Tightening

INFOID:000000003887319

- Use the angle wrench [SST: KV10112100 (BT8653-A)] for the final tightening of the following engine parts:
 - Cylinder head bolts
 - Lower cylinder block bolts
 - Connecting rod cap bolts
- Do not use a torque value for final tightening.
- The torque value for these parts are for a preliminary step.
- Ensure thread and seat surfaces are clean and coated with engine oil.

Liquid Gasket

INFOID:000000003887320

REMOVAL OF LIQUID GASKET SEALING

- After removing mounting bolts and nuts, separate the mating surface using the seal cutter [SST: KV10111100 (J-37228)] (A) and remove old liquid gasket sealing.

CAUTION:

Be careful not to damage the mating surfaces.

- Tap the seal cutter to insert it (B), and then slide it (C) by tapping on the side as shown in the figure.
- In areas where the seal cutter is difficult to use, use a plastic hammer to lightly tap the parts, to remove it.

CAUTION:

If for some unavoidable reason tool such as a screwdriver is used, be careful not to damage the mating surfaces.

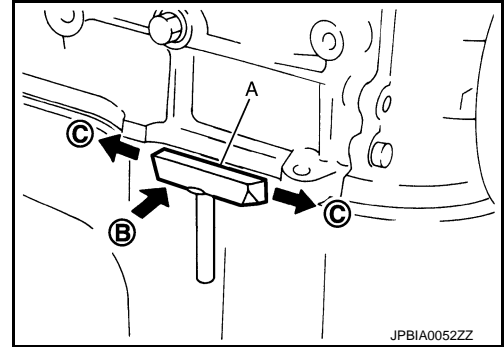

LIQUID GASKET APPLICATION PROCEDURE

1. Using a scraper (A), remove old liquid gasket adhering to the liquid gasket application surface and the mating surface.
 - Remove liquid gasket completely from the groove of the liquid gasket application surface, mounting bolts, and bolt holes.
2. Wipe the liquid gasket application surface and the mating surface with white gasoline (lighting and heating use) to remove adhering moisture, grease and foreign materials.

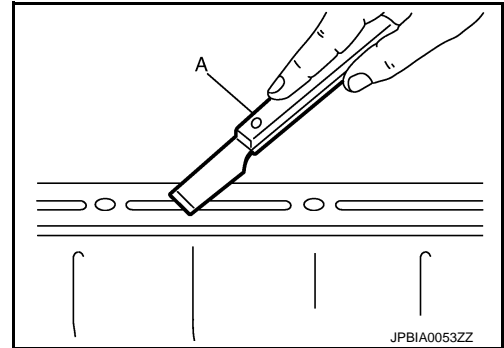

3. Attach liquid gasket tube to the tube presser (commercial service tool).

Use Genuine RTV Silicone Sealant or an equivalent. Refer to GI-15, "Recommended Chemical Products and Sealants".
4. Apply liquid gasket without breaks to the specified location with the specified dimensions.
 - If there is a groove for liquid gasket application, apply liquid gasket to the groove.

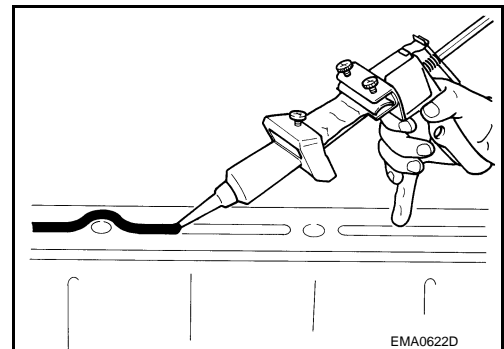

PRECAUTIONS

[VQ35HR]

< PRECAUTION >

- As for bolt holes (B), normally apply liquid gasket inside the holes. Occasionally, it should be applied outside the holes. Check to read the text of this manual.

A : Groove

↩ : Inside

- Within 5 minutes of liquid gasket application, install the mating component.
- If liquid gasket protrudes, wipe it out immediately.
- Do not retighten mounting bolts or nuts after the installation.
- After 30 minutes or more is passed after the installation, fill engine oil and engine coolant.

CAUTION:

If there are specific instructions in this manual, observe them.

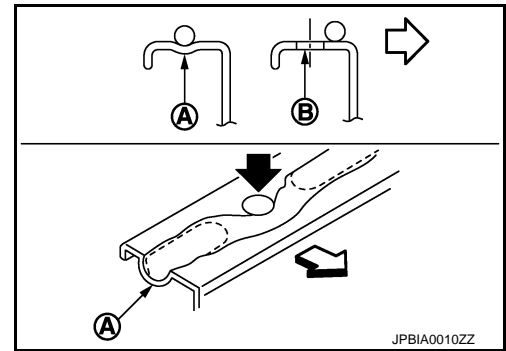

Definitions of Bank Names

INFOID:000000003887321

- In this manual, each bank name is defined as per the following:

A : Bank 1 (The conventional right bank)

B : Bank 2 (The conventional left bank)

↩ : Engine front

- For cylinder numbers and bank layout, refer to the figure.

Bank 1 : The bank side including cylinder No. 1 (odd-numbered cylinder side)

Bank 2 : The other bank side of the above (even-numbered cylinder side)

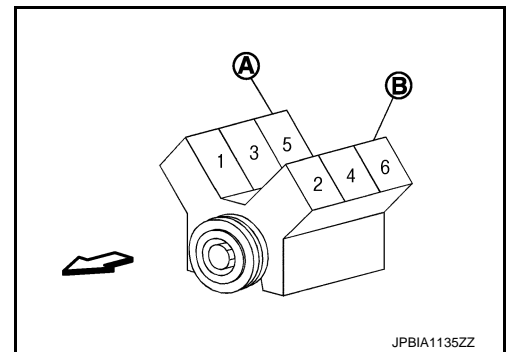

PREPARATION

< PREPARATION >

[VQ35HR]

PREPARATION

PREPARATION

Special Service Tools

INFOID:000000003887322

A

EM

The actual shapes of Kent-Moore tools may differ from those of special service tools illustrated here.

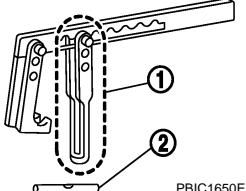
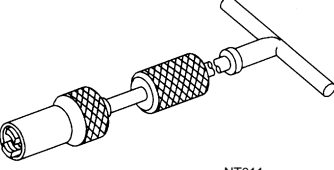
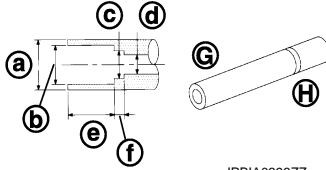
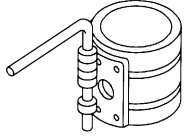
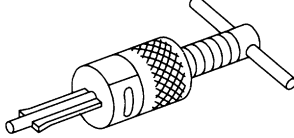
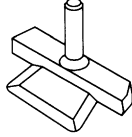
Tool number (Kent-Moore No.) Tool name	Description
KV10116200 (J-26336-A) Valve spring compressor 1. KV10115900 (J-26336-20) Attachment 2.KV10109220 (—) Adapter	 Disassembling valve mechanism Part (1) is a component of KV10116200 (J-26336-A), but Part (2) is not so.
KV10107902 (J-38959) Valve oil seal puller	 Replacing valve oil seal
KV10115600 (J-38958) Valve oil seal drift	 Installing valve oil seal Use side A (G). a: 20 (0.79) dia. d: 8 (0.31) dia. b: 13 (0.51) dia. e: 10.7 (0.421) c: 10.3 (0.406) dia. f: 5 (0.20) H: side B Unit: mm (in)
EM03470000 (J-8037) Piston ring compressor	 Installing piston assembly into cylinder bore
ST16610001 (J-23907) Pilot bushing puller	 Removing pilot converter
KV10111100 (J-37228) Seal cutter	 Removing oil pan (lower and upper), front and rear timing chain case, etc.

C

D

E

F

G

H

I

J

K

L

M

N

O

P

PREPARATION

< PREPARATION >

[VQ35HR]

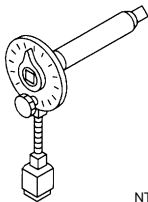
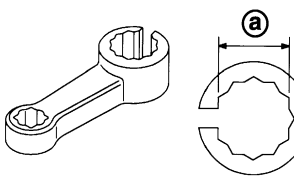
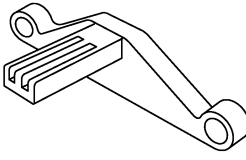
Tool number (Kent-Moore No.) Tool name	Description
KV10112100 (BT8653-A) Angle wrench  <p style="text-align: right; margin-right: 50px;">NT014</p>	Tightening bolts for connecting rod bearing cap, cylinder head, etc. in angle
KV10114400 (J-38365) Heated oxygen sensor wrench  <p style="text-align: right; margin-right: 50px;">JPBIA0397ZZ</p>	Loosening or tightening air fuel ratio sensor 1 a: 22 mm (0.87 in)
KV10118600 (J-48641) Ring gear stopper  <p style="text-align: right; margin-right: 50px;">JPBIA0409ZZ</p>	Removing and installing crankshaft pulley

Commercial Service Tools

INFOID:000000003887323

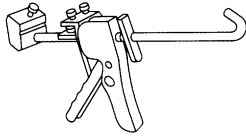
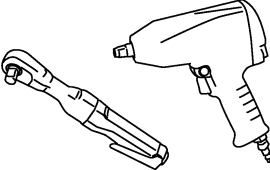
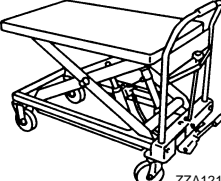
(Kent-Moore No.) Tool name	Description
(—) Tube presser  <p style="text-align: right; margin-right: 50px;">NT052</p>	Pressing the tube of liquid gasket
(—) Power tool  <p style="text-align: right; margin-right: 50px;">PBIC0190E</p>	Loosening bolts and nuts
(—) Manual lift table caddy  <p style="text-align: right; margin-right: 50px;">ZZA1210D</p>	Removing and installing engine

PREPARATION

< PREPARATION >

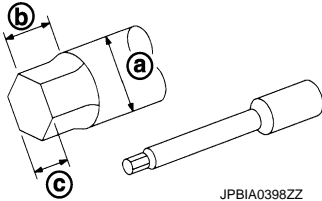
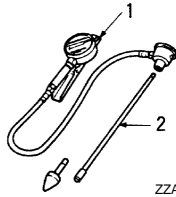
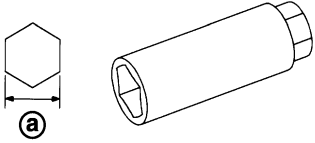
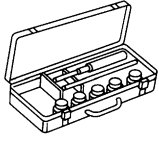
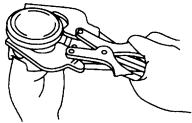
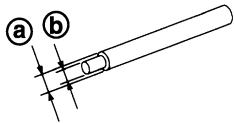
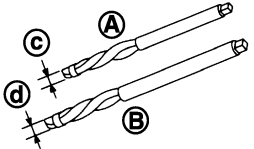

[VQ35HR]

(Kent-Moore No.) Tool name	Description	
(J24239-01) Cylinder head bolt wrench <div style="text-align: center;">  <p style="font-size: small;">JPBIA0398ZZ</p> </div>	Loosening and tightening cylinder head bolt, and used with the angle wrench [SST: KV10112100 (BT8653-A)] a: 13 mm (0.51 in) dia. b: 12 mm (0.47 in) c: 10 mm (0.39 in)	A EM C
(—) 1. Compression gauge 2. Adapter <div style="text-align: center;">  <p style="font-size: small;">ZZA0008D</p> </div>	Checking compression pressure	D E
(—) Spark plug wrench <div style="text-align: center;">  <p style="font-size: small;">JPBIA0399ZZ</p> </div>	Removing and installing spark plug a: 14 mm (0.55 in)	F G H
(—) Valve seat cutter set <div style="text-align: center;">  <p style="font-size: small;">NT048</p> </div>	Finishing valve seat dimensions	I J
(—) Piston ring expander <div style="text-align: center;">  <p style="font-size: small;">NT030</p> </div>	Removing and installing piston ring	K L M
(—) Valve guide drift <div style="text-align: center;">  <p style="font-size: small;">JPBIA0400ZZ</p> </div>	Removing and installing valve guide Intake and Exhaust: a: 9.5 mm (0.374 in) dia. b: 5.5 mm (0.217 in) dia.	N O
(—) Valve guide reamer <div style="text-align: center;">  <p style="font-size: small;">JPBIA0401ZZ</p> </div>	A: Reaming valve guide inner hole B: Reaming hole for oversize valve guide Intake and Exhaust: c: 6.0 mm (0.236 in) dia. d: 10.2 mm (0.402 in) dia.	P

PREPARATION

< PREPARATION >

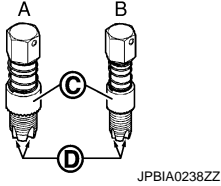
[VQ35HR]

(Kent-Moore No.) Tool name	Description
(J-43897-18) (J-43897-12) Oxygen sensor thread cleaner 	Reconditioning the exhaust system threads before installing a new air fuel ratio sensor and heated oxygen sensor (Use with anti-seize lubricant shown below.) A: J-43897-18 [18 mm (0.71 in) dia.] for zirconia heated oxygen sensor and air fuel ratio sensor B: J-43897-12 [12 mm (0.47 in) dia.] for titania heated oxygen sensor C: Mating surface shave cylinder D: Flutes
(—) Anti-seize lubricant (Permatex 133AR or an equivalent meeting MIL specification MIL-A-907) 	Lubricating oxygen sensor thread cleaning tool when reconditioning exhaust system threads

PERIODIC MAINTENANCE

DRIVE BELT

Exploded View

INFOID:000000003887324

A

EM

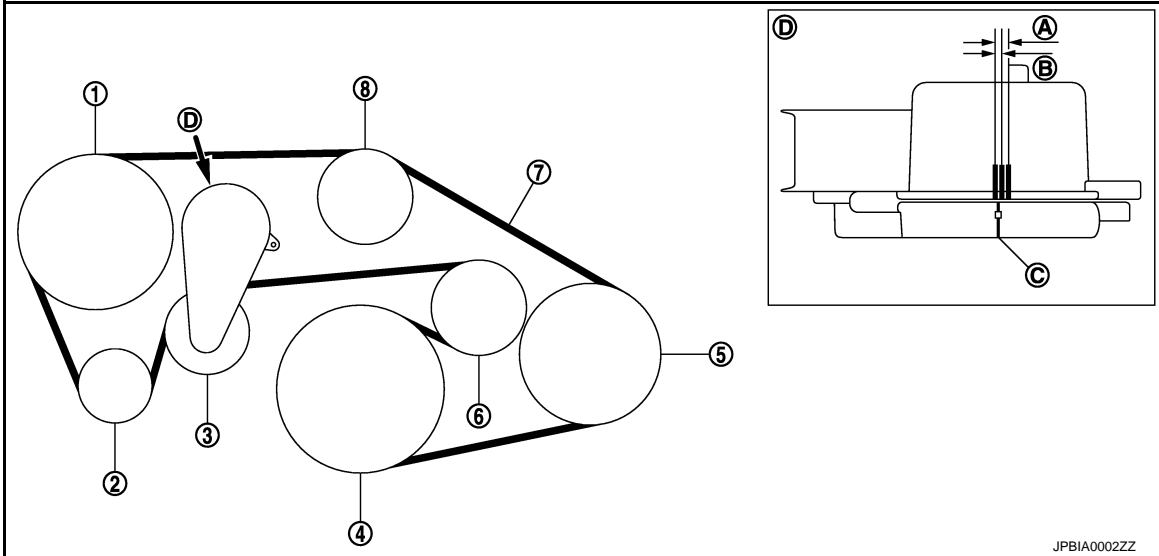

- | | | |
|----------------------------|---|------------------------------|
| 1. Power steering oil pump | 2. Alternator | 3. Drive belt auto-tensioner |
| 4. Crankshaft pulley | 5. A/C compressor | 6. Idler pulley |
| 7. Drive belt | 8. Idler pulley | |
| A. Possible use range | B. Range when new drive belt is installed | C. Indicator |
| D. View D | | |

Checking

INFOID:000000003887325

WARNING:

Be sure to perform this step when engine is stopped.

- Check that the indicator (C) (notch on fixed side) of drive belt auto-tensioner is within the possible use range (A).

C

D

E

F

G

H

I

J

K

L

M

N

O

P

NOTE:

- Check the drive belt auto-tensioner indication when the engine is cold.
- When new drive belt is installed, the indicator (notch on fixed side) should be within the range (B) in the figure.
- Visually check entire drive belt for wear, damage or cracks.
- If the indicator (notch on fixed side) is out of the possible use range or belt is damaged, replace drive belt.

Tension Adjustment

INFOID:000000003887326

Refer to [EM-142. "Drive Belt"](#).

Removal and Installation

INFOID:000000003887327

REMOVAL

1. Remove engine undercover with power tool.

DRIVE BELT

[VQ35HR]

< PERIODIC MAINTENANCE >

2. While securely holding the square hole (A) in pulley center of auto tensioner (1) with a spinner handle, move spinner handle in the direction of arrow (loosening direction of drive belt).

← : Loosening direction of drive belt

CAUTION:

Never place hand in a location where pinching may occur if the holding tool accidentally comes off.

3. Under the above condition, insert a metallic bar of approximately 6 mm (0.24 in) in diameter [hexagonal wrench (C) shown as example in the figure] through the holding boss (B) to lock auto-tensioner pulley arm.
4. Remove drive belt.

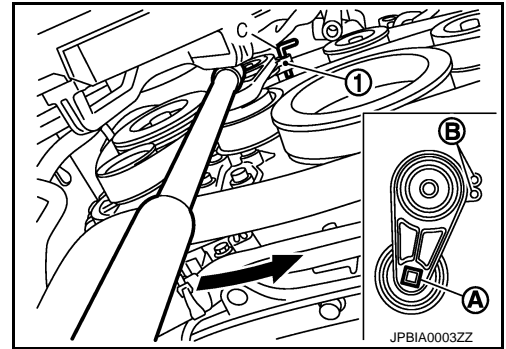

INSTALLATION

Note the following item, and install in the reverse order of removal.

CAUTION:

- Check drive belt is securely installed around all pulleys.
- Check drive belt is correctly engaged with the pulley groove.
- Check for engine oil and engine coolant are not adhered drive belt and pulley groove.

Inspection

INFOID:000000003887328

INSPECTION AFTER INSTALLATION

- Turn crankshaft pulley clockwise several times to equalize tension between each pulley, and then confirm tension of drive belt at indicator (notch on fixed side) is within the possible use range. Refer to [EM-15, "Exploded View"](#).

AIR CLEANER FILTER

Removal and Installation

INFOID:000000003887329

REMOVAL

1. Unhook clips (A).

- 1 : Holder
- 2 : Air cleaner case

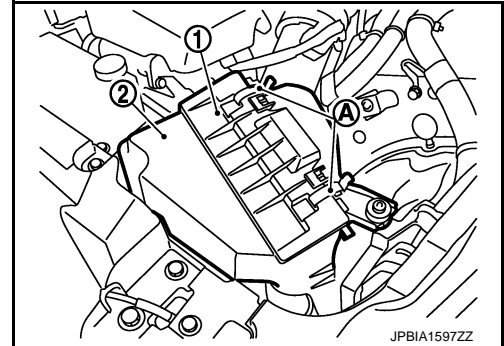

2. Remove holder (3) from air cleaner case (2), and then remove air cleaner filter (1) from holder.

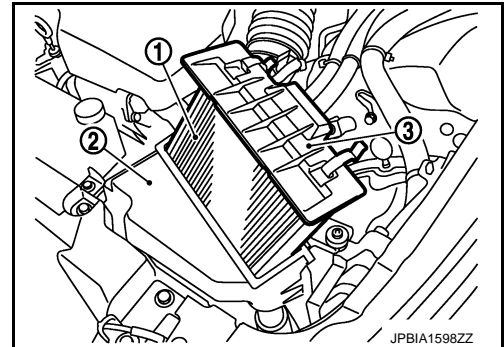

INSTALLATION

Note the following item, and install in the reverse order of removal.

- Install the air cleaner filter by aligning the seal with the notch of air cleaner case.

A
EM
C
D
E
F
G
H
I
J
K
L
M
N
O
P

SPARK PLUG

< PERIODIC MAINTENANCE >

[VQ35HR]

SPARK PLUG

Exploded View

INFOID:000000003887330

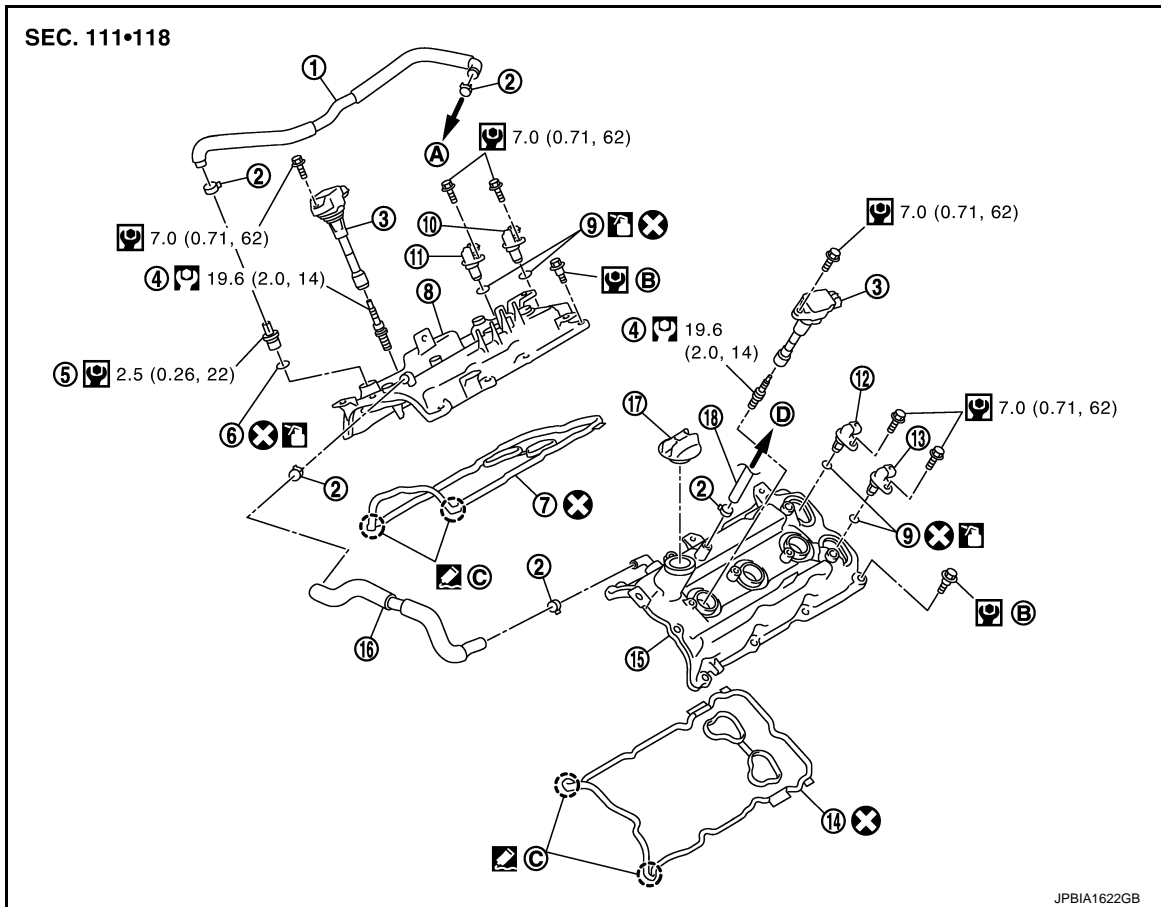

- | | | |
|---|---|---|
| 1. PCV hose | 2. Clamp | 3. Ignition coil |
| 4. Spark plug | 5. PCV valve | 6. O-ring |
| 7. Rocker cover gasket (bank 1) | 8. Rocker cover (bank 1) | 9. O-ring |
| 10. Camshaft position sensor (PHASE) (bank 1) | 11. Exhaust valve timing control position sensor (bank 1) | 12. Camshaft position sensor (PHASE) (bank 2) |
| 13. Exhaust valve timing control position sensor (bank 2) | 14. Rocker cover gasket (bank 2) | 15. Rocker cover (bank 2) |
| 16. PCV hose | 17. Oil filler cap | 18. PCV hose |
| A. To intake manifold collector | B. Refer to EM-50 | C. Camshaft bracket side |
| D. To air duct | | |

Refer to [GI-4, "Components"](#) for symbols in the figure.

Removal and Installation

INFOID:000000003887331

REMOVAL

1. Remove engine cover with power tool. Refer to [EM-27, "Exploded View"](#).
2. Remove air duct. Refer to [EM-29, "Exploded View"](#).
3. Remove electric throttle control actuator. Refer to [EM-31, "Exploded View"](#).
4. Remove ignition coil. Refer to [EM-50, "Removal and Installation"](#).

SPARK PLUG

[VQ35HR]

< PERIODIC MAINTENANCE >

- Remove spark plug with a spark plug wrench (commercial service tool).

a : 14 mm (0.55 in)

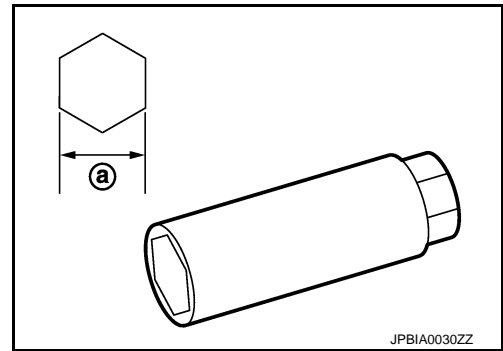

INSTALLATION

Installation is the reverse order of removal.

Inspection

INFOID:000000003887332

INSPECTION AFTER REMOVAL

Use the standard type spark plug for normal condition.

Spark plug (Standard type) : Refer to [EM-143, "Spark Plug"](#).

CAUTION:

- Never drop or impact spark plug.
- Never use a wire brush for cleaning.
- If plug tip is covered with carbon, spark plug cleaner may be used.

Cleaner air pressure: Less than 588 kPa (6 kg/cm², 85 psi)

Cleaning time: Less than 20 seconds

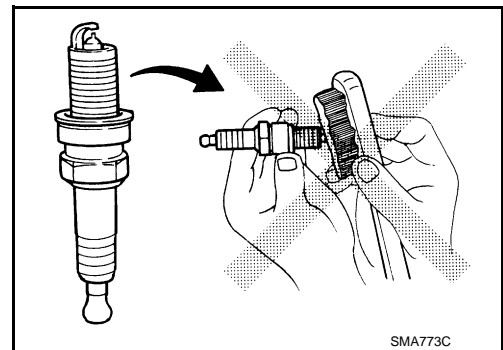

- Measure spark plug gap. When it exceeds the limit, replace spark plug even if it is within the specified replacement mileage. Refer to [EM-143, "Spark Plug"](#).
- Spark plug gap adjustment is not required between replacement intervals.

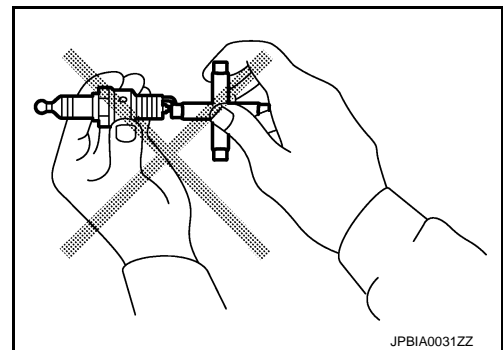

CAMSHAFT VALVE CLEARANCE

< PERIODIC MAINTENANCE >

[VQ35HR]

CAMSHAFT VALVE CLEARANCE

Inspection and Adjustment

INFOID:00000003887333

INSPECTION

Perform inspection as follows after removal, installation or replacement of camshaft or valve-related parts, or if there is unusual engine conditions regarding valve clearance.

In cases of removing/installing or replacing camshaft and valve-related parts, or of unusual engine conditions due to changes in valve clearance (found malfunctions during starting, idling or causing noise), perform inspection as follows:

⇨ : Engine front

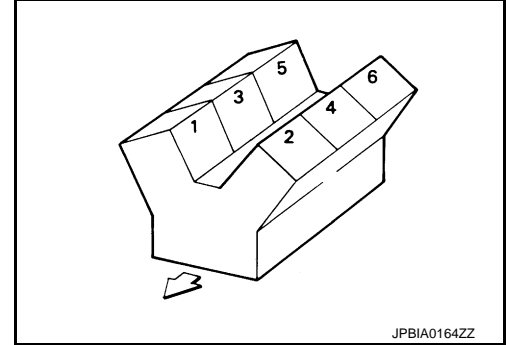

1. Remove rocker covers (bank 1 and bank 2). Refer to [EM-50. "Removal and Installation"](#).
2. Measure the valve clearance as per the following:
 - a. Set No. 1 cylinder at TDC of its compression stroke.
 - Rotate crankshaft pulley clockwise to align timing mark (grooved line without color) with timing indicator.

⇨ : Timing mark (grooved line without color)

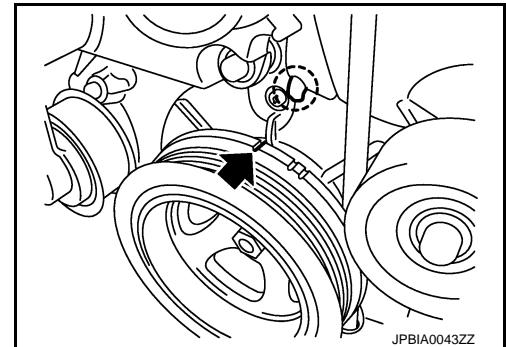

- Check that intake and exhaust cam nose on No. 1 cylinder (engine front side of bank 1) are located as shown in the figure.

⇨ : Engine front

- If not, turn crankshaft one revolution (360 degrees) and align as shown in the figure.

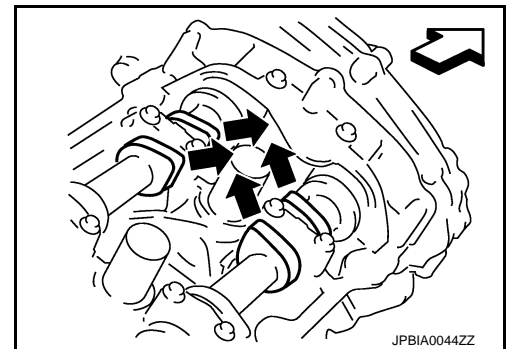

- b. Use a feeler gauge, measure the clearance between valve lifter and camshaft.

Valve clearance : Refer to [EM-143. "Camshaft"](#).

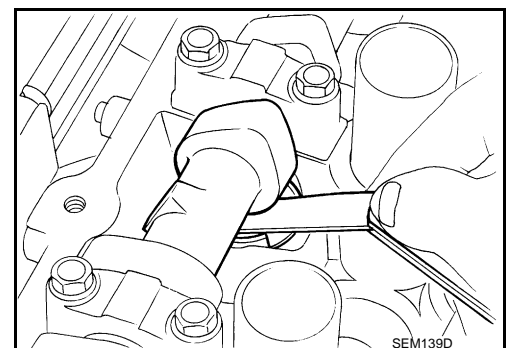

CAMSHAFT VALVE CLEARANCE

[VQ35HR]

< PERIODIC MAINTENANCE >

- By referring to the figure, measure the valve clearances at locations marked "x" as shown in the table below (locations indicated in the figure).

← : Engine front

- No. 1 cylinder at compression TDC

Measuring position [bank 1 (A)]		No. 1 CYL.	No. 3 CYL.	No. 5 CYL.
No. 1 cylinder at compression TDC	EXH (C)		x (B)	
	INT (D)	x (E)		
Measuring position [bank 2 (H)]		No. 2 CYL.	No. 4 CYL.	No. 6 CYL.
No. 1 cylinder at compression TDC	INT (D)			x (F)
	EXH (C)	x (G)		

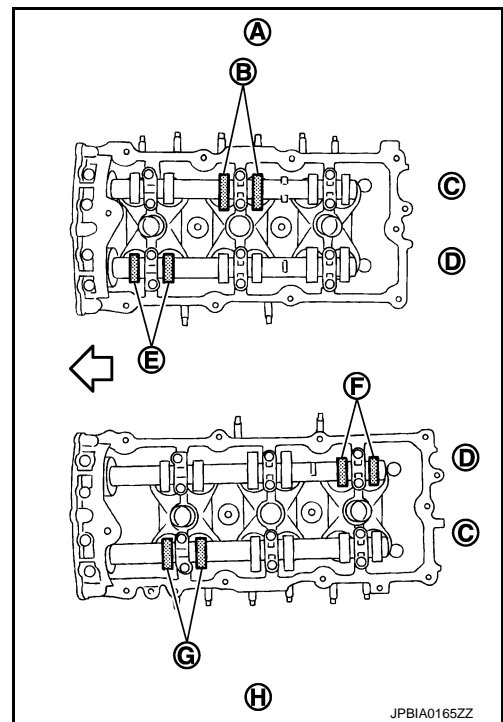

- c. Rotate crankshaft 240 degrees clockwise (when viewed from engine front) to align No. 3 cylinder at TDC its compression stroke.

NOTE:

Mark a position 240 degrees (b) from a corner of the hexagonal part of crankshaft pulley mounting bolt as shown in the figure. Use the hexagonal part as a guide.

- 1 : Crankshaft pulley
- A : Paint mark

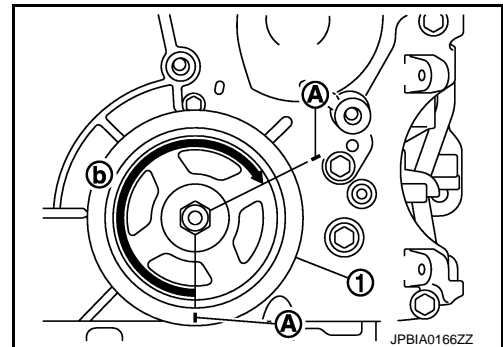

A
EM
C
D
E
F
G
H
I
J
K
L
M
N
O
P

CAMSHAFT VALVE CLEARANCE

[VQ35HR]

< PERIODIC MAINTENANCE >

- By referring to the figure, measure the valve clearances at locations marked "×" as shown in the table below (locations indicated in the figure).

← : Engine front

- No. 3 cylinder at compression TDC

Measuring position [bank 1 (A)]		No. 1 CYL.	No. 3 CYL.	No. 5 CYL.
No. 3 cylinder at compression TDC	EXH (C)			× (B)
	INT (D)		× (E)	
Measuring position [bank 2 (H)]		No. 2 CYL.	No. 4 CYL.	No. 6 CYL.
No. 3 cylinder at compression TDC	INT (D)	× (F)		
	EXH (C)		× (G)	

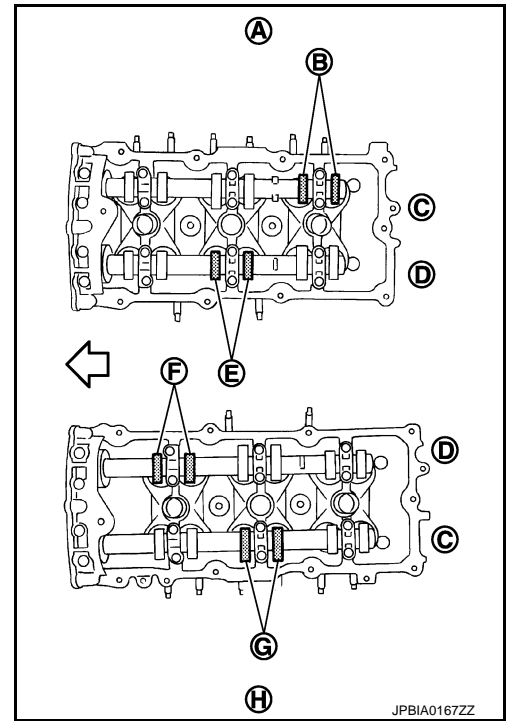

- d. Rotate crankshaft 240 degrees clockwise (when viewed from engine front) to align No. 5 cylinder at TDC of compression stroke.

NOTE:

Mark a position 240 degrees (b) from a corner of the hexagonal part of crankshaft pulley mounting bolt as shown in the figure. Use the hexagonal part as a guide.

- 1 : Crankshaft pulley
- A : Paint mark

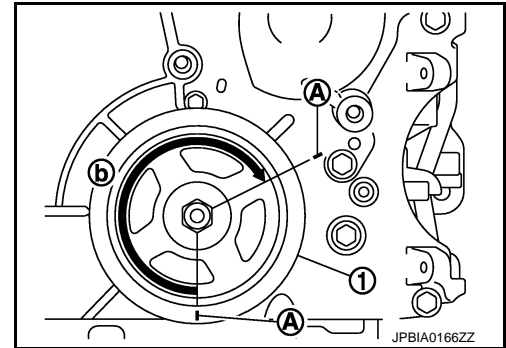

CAMSHAFT VALVE CLEARANCE

[VQ35HR]

< PERIODIC MAINTENANCE >

- By referring to the figure, measure the valve clearances at locations marked "x" as shown in the table below (locations indicated in the figure).

← : Engine front

- No. 5 cylinder at compression TDC

Measuring position [bank 1 (A)]		No. 1 CYL.	No. 3 CYL.	No. 5 CYL.
No. 5 cylinder at compression TDC	EXH (C)	x (B)		
	INT (D)			x (E)
Measuring position [bank 2 (H)]		No. 2 CYL.	No. 4 CYL.	No. 6 CYL.
No. 5 cylinder at compression TDC	INT (D)		x (F)	
	EXH (C)			x (G)

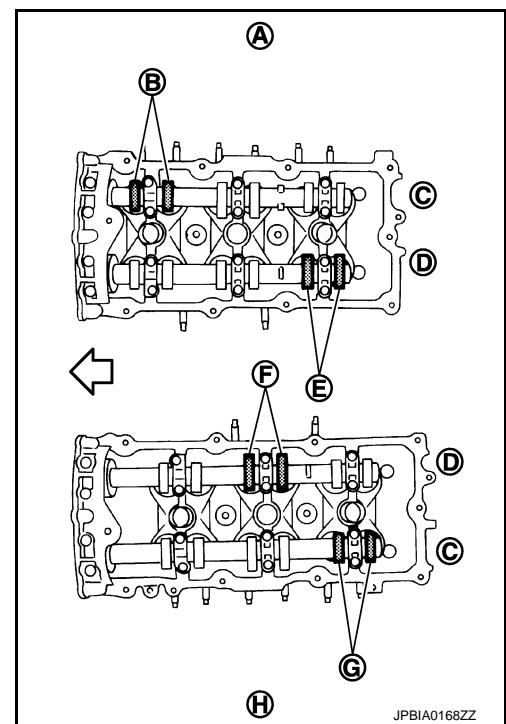

- Perform adjustment if the measured value is out of the standard. Refer to "ADJUSTMENT".

ADJUSTMENT

- Perform adjustment depending on selected head thickness of valve lifter.
 - Measure the valve clearance. Refer to "INSPECTION".
 - Remove camshaft. Refer to [EM-70. "Removal and Installation"](#).
 - Remove valve lifters at the locations that are out of the standard.
 - Measure the center thickness of the removed valve lifters with a micrometer (A).

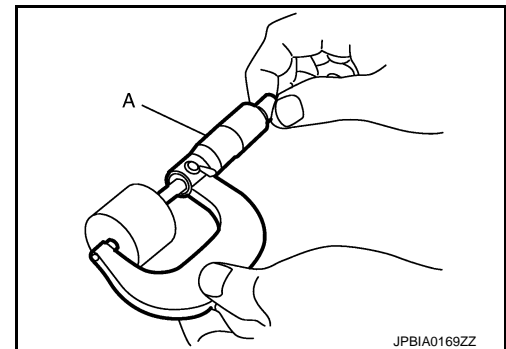

- Use the equation below to calculate valve lifter thickness for replacement.

Valve lifter thickness calculation: $t = t_1 + (C_1 - C_2)$

- t** = Valve lifter thickness to be replaced
- t₁** = Removed valve lifter thickness
- C₁** = Measured valve clearance
- C₂** = Standard valve clearance:
 - Intake** : 0.30 mm (0.012 in)
 - Exhaust** : 0.33 mm (0.013 in)

CAMSHAFT VALVE CLEARANCE

[VQ35HR]

< PERIODIC MAINTENANCE >

- Thickness of new valve lifter can be identified by stamp marks on the reverse side (inside the cylinder).
Stamp mark 788 indicates 7.88 mm (0.3102 in) in thickness.

A : Stamp

B : Thickness of valve lifter

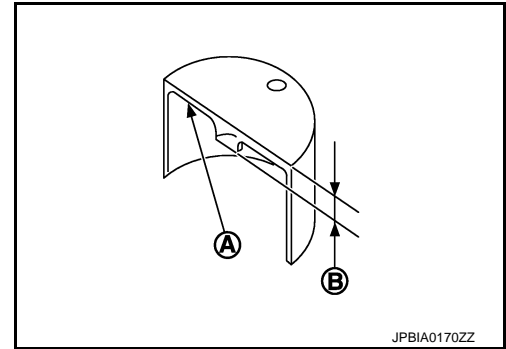

Available thickness of valve lifter: 27 sizes with range 7.88 to 8.40 mm (0.3102 to 0.3307 in) in steps of 0.02 mm (0.0008 in) (when manufactured at factory). Refer to [EM-143, "Camshaft"](#).

6. Install selected valve lifter.
7. Install camshaft. Refer to [EM-70, "Removal and Installation"](#).
8. Manually turn crankshaft pulley a few turns.
9. Check that the valve clearances for cold engine are within the specifications by referring to the specified values. Refer to [EM-20, "Inspection and Adjustment"](#).
10. Install all removal parts in the reverse order of removal.
11. Warm up the engine, and check for unusual noise and vibration.

COMPRESSION PRESSURE

Inspection

INFOID:000000003887334

1. Warm up engine thoroughly. Then, stop it.
2. Release fuel pressure. Refer to [EC-567, "Inspection"](#).
3. Disconnect fuel pump fuse (1) from IPDM E/R (2) to avoid fuel injection during measurement.

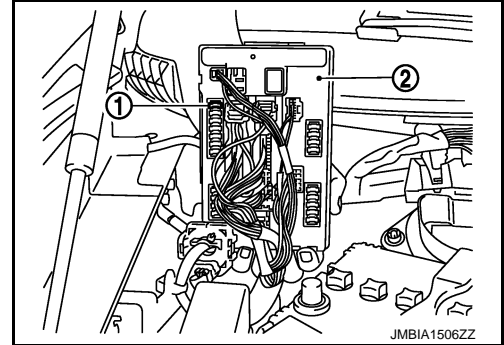

4. Remove engine cover with power tool. Refer to [EM-27, "Exploded View"](#).
5. Remove ignition coil and spark plug from each cylinder. Refer to [EM-50, "Exploded View"](#).
6. Connect engine tachometer (not required in use of CONSULT-III).
7. Install compression gauge with an adapter (commercial service tool) onto spark plug hole.

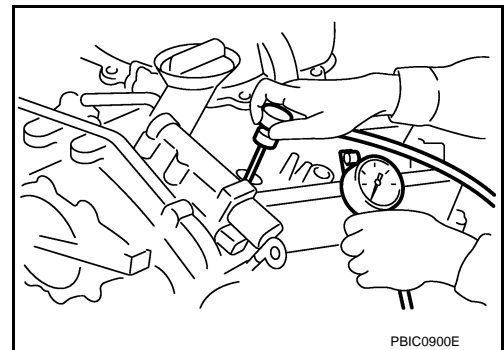

- Use the adapter hat has a smaller than 20 mm (0.79 in) (a) as shown in the figure. Otherwise, it may be caught by cylinder head during removal.

a : 20 mm (0.79 in)

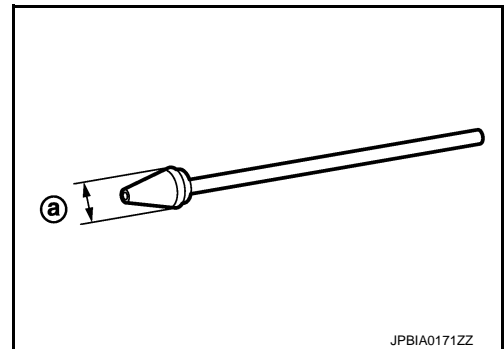

8. With accelerator pedal fully depressed, turn ignition switch to "START" for cranking. When the gauge pointer stabilizes, read the compression pressure and the engine rpm. Perform these steps to check each cylinder.

Compression pressure : Refer to [EM-142, "General Specification"](#).

CAUTION:

Always use a fully charged battery to obtain the specified engine speed.

- If the engine speed is out of the specified range, check battery liquid for proper gravity. Check the engine speed again with normal battery gravity. Refer to [PG-3, "How to Handle Battery"](#).
- If compression pressure is below minimum value, check valve clearances and parts associated with combustion chamber (valve, valve seat, piston, piston ring, cylinder bore, cylinder head, cylinder head gasket). After the checking, measure compression pressure again.

COMPRESSION PRESSURE

[VQ35HR]

< PERIODIC MAINTENANCE >

- If some cylinder has low compression pressure, pour small amount of engine oil into the spark plug hole of the cylinder to re-check it for compression.
 - If the added engine oil improves the compression, piston rings may be worn out or damaged. Check piston rings and replace if necessary.
 - If the compression pressure remains at low level despite the addition of engine oil, valves may be malfunctioning. Check valves for damage. Replace valve or valve seat accordingly.
 - If two adjacent cylinders have respectively low compression pressure and their compression remains low even after the addition of engine oil, cylinder head gaskets are leaking. In such a case, replace cylinder head gaskets.
9. After inspection is completed, install removed parts.
 10. Start the engine, and check that the engine runs smoothly.
 11. Perform trouble diagnosis. If DTC appears, erase it. Refer to [EC-136, "Description"](#).

REMOVAL AND INSTALLATION

ENGINE COVER

Exploded View

INFOID:000000003887335

1 : Engine cover

Refer to [GI-4, "Components"](#) for symbols in the figure.

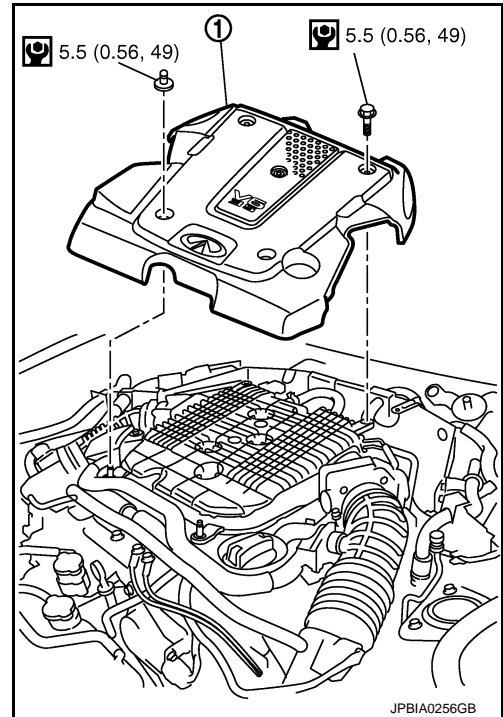

Removal and Installation

INFOID:000000003887336

REMOVAL

Loosen mounting bolts and nuts in the reverse order as shown in the figure, and then remove engine cover.

CAUTION:

Never damage or scratch engine cover when installing or removing.

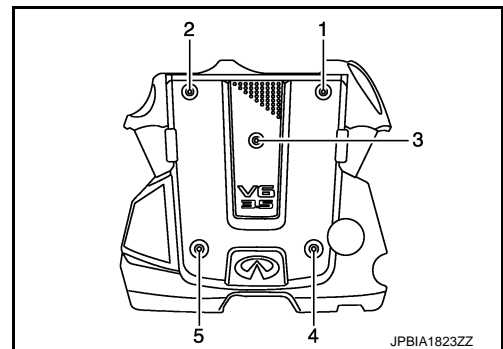

INSTALLATION

Install engine cover, and then tighten mounting bolts and nuts in numerical order as shown in the figure.

CAUTION:

Never damage or scratch engine cover when installing or removing.

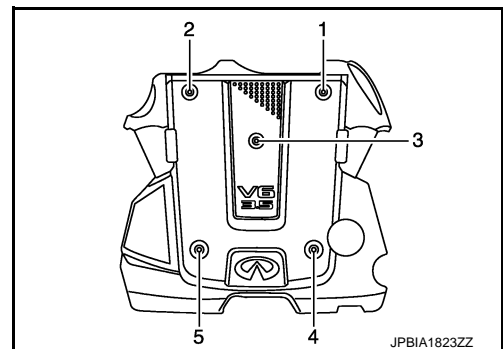

A
EM
C
D
E
F
G
H
I
J
K
L
M
N
O
P

DRIVE BELT AUTO TENSIONER AND IDLER PULLEY

< REMOVAL AND INSTALLATION >

[VQ35HR]

DRIVE BELT AUTO TENSIONER AND IDLER PULLEY

Exploded View

INFOID:000000003887337

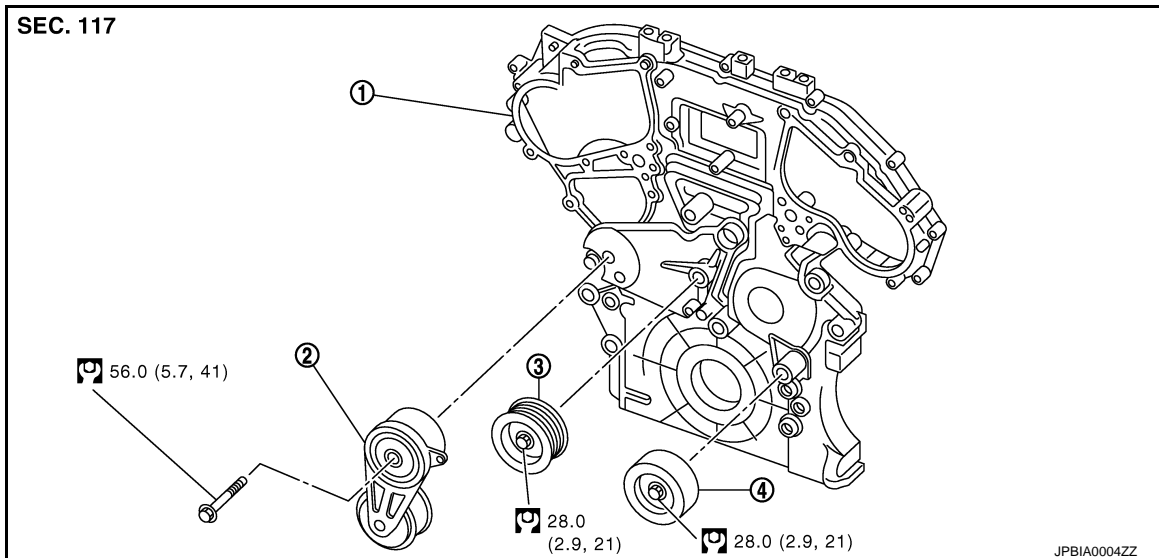

1. Front timing chain case
2. Drive belt auto-tensioner
3. Idler pulley
4. Idler pulley

Refer to [GI-4, "Components"](#) for symbols in the figure.

Removal and Installation

INFOID:000000003887338

Removal

1. Remove drive belt. Refer to [EM-15, "Exploded View"](#).
 - Keep auto-tensioner pulley arm locked after drive belt is removed.
2. Remove auto-tensioner and idler pulley.
 - Keep auto-tensioner pulley arm locked to install or remove auto-tensioner.

Installation

Installation is the reverse order of removal.

CAUTION:

If there is damage greater than peeled paint, replace drive belt auto-tensioner.

AIR CLEANER AND AIR DUCT

< REMOVAL AND INSTALLATION >

[VQ35HR]

AIR CLEANER AND AIR DUCT

Exploded View

INFOID:000000003887339

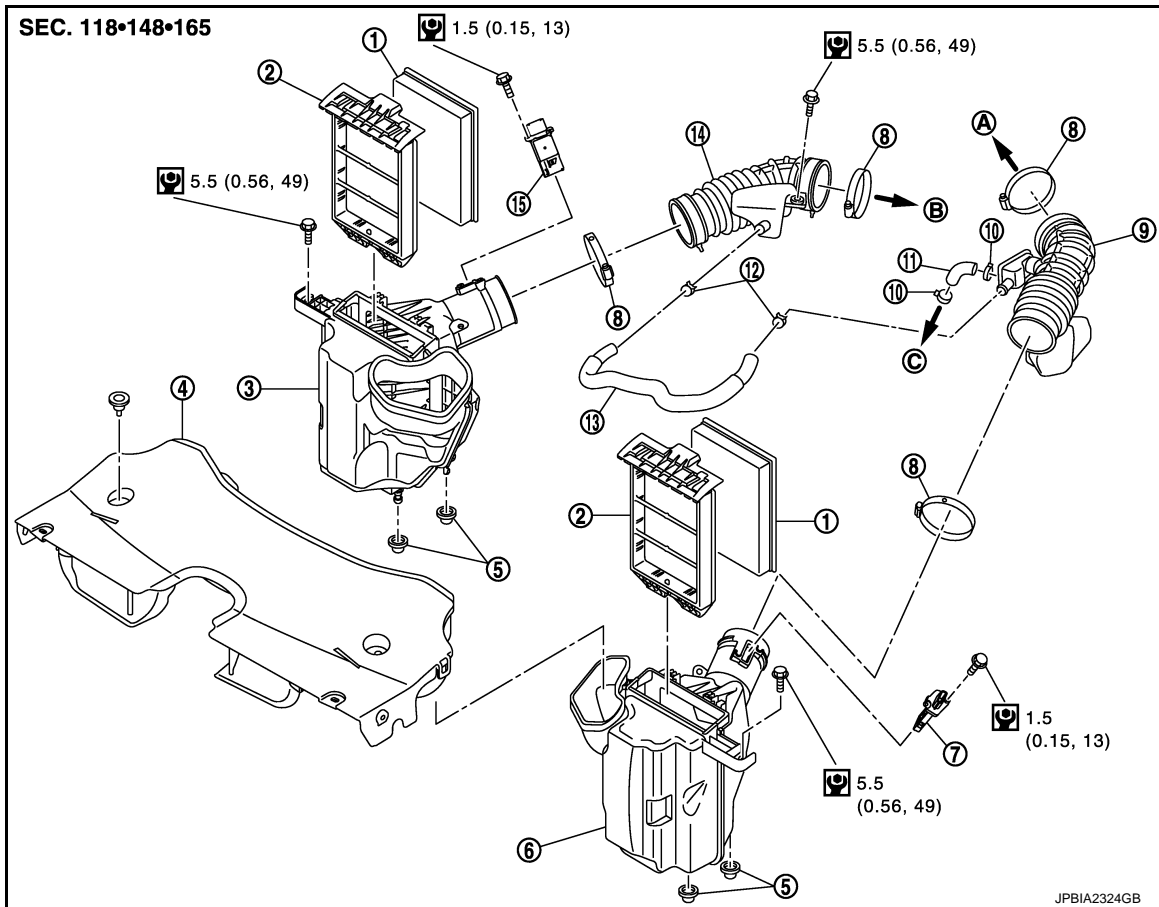

- | | | |
|---|---|-----------------------------------|
| 1. Air cleaner filter | 2. Holder | 3. Air cleaner case (bank 1) |
| 4. Air duct (inlet) | 5. Grommet | 6. Air cleaner case (bank 2) |
| 7. Mass air flow sensor (bank 2) | 8. Clamp | 9. Air duct (bank 2) |
| 10. Clamp | 11. PCV hose | 12. Clamp |
| 13. PCV hose | 14. Air duct (bank 1) | 15. Mass air flow sensor (bank 1) |
| A. To electric throttle control actuator (bank 2) | B. To electric throttle control actuator (bank 1) | C. To rocker cover (bank 2) |

Refer to [GI-4, "Components"](#) for symbols in the figure.

Removal and Installation

INFOID:000000003887340

REMOVAL

1. Disconnect mass air flow sensor harness connector.
2. Disconnect PCV hose.
3. Remove air cleaner case with mass air flow sensor and air duct, disconnecting each joints.
 - Add matching marks, if necessary for easier installation.
4. Remove mass air flow sensor from air cleaner case, if necessary.

CAUTION:

Handle mass air flow sensor with the following cares.

- Never impact mass air flow sensor.
- Never disassemble mass air flow sensor.
- Never touch mass air flow sensor.

INSTALLATION

AIR CLEANER AND AIR DUCT

[VQ35HR]

< REMOVAL AND INSTALLATION >

Note the following item, and install in the reverse order of removal.

- Align marks. Attach each joint. Screw clamps firmly.

Clamp tightening torque  :4.5 N·m (0.46 kg-m, 40 in-lb)

Inspection

INFOID:000000003887341

INSPECTION AFTER REMOVAL

Inspect air duct and resonator if assembly for crack or tear.

- If damage found, replace air duct and resonator assembly.

INTAKE MANIFOLD COLLECTOR

< REMOVAL AND INSTALLATION >

[VQ35HR]

INTAKE MANIFOLD COLLECTOR

Exploded View

INFOID:000000003887342

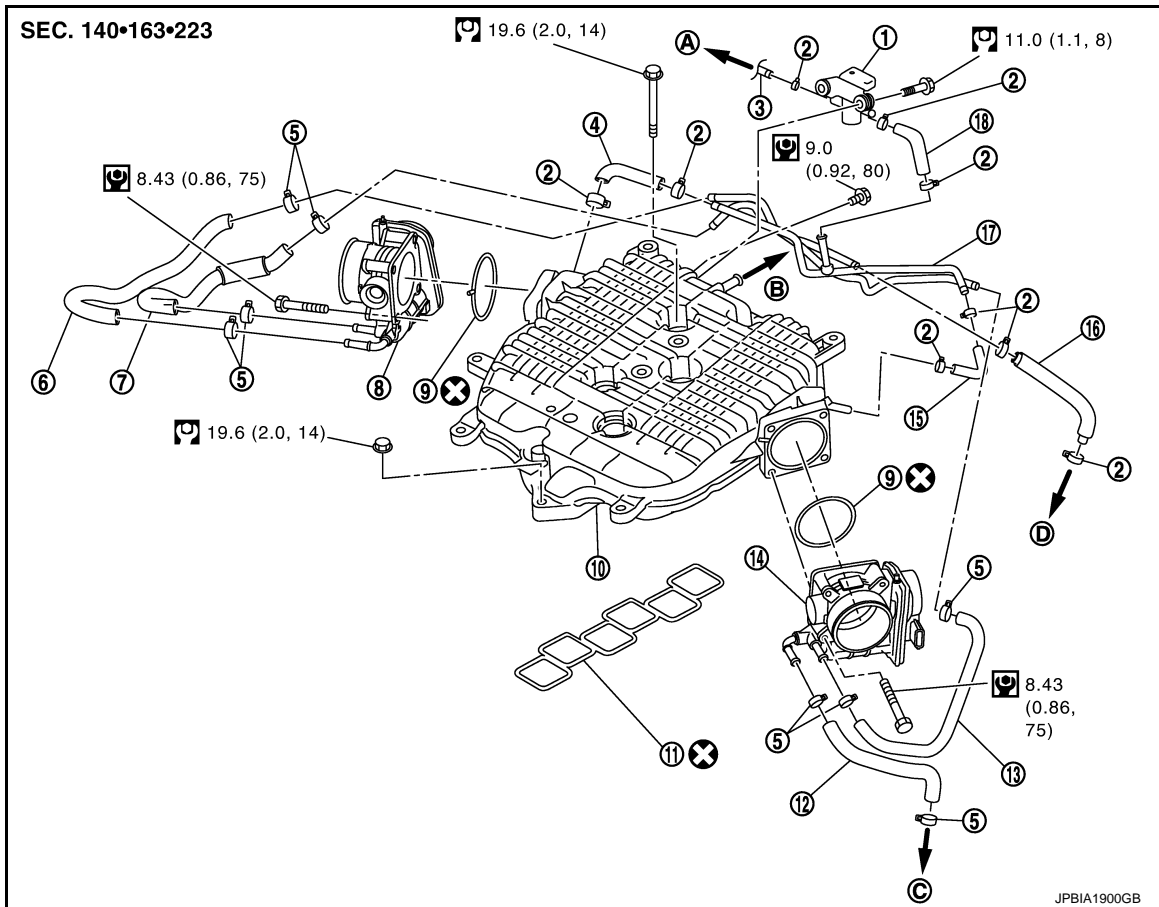

- | | | |
|---|--|----------------|
| 1. EVAP canister purge control solenoid valve | 2. Clamp | 3. EVAP hose |
| 4. EVAP hose | 5. Clamp | 6. Water hose |
| 7. Water hose | 8. Electric throttle control actuator (bank1) | 9. Gasket |
| 10. Intake manifold collector | 11. Gasket | 12. Water hose |
| 13. Water hose | 14. Electric throttle control actuator (bank2) | 15. EVAP hose |
| 16. Water hose | 17. EVAP tube assembly | 18. EVAP hose |
- A. To vacuum pipe
B. To brake booster
C. To heater pipe
D. To water outlet (rear)

Refer to [GI-4, "Components"](#) for symbols in the figure.

Removal and Installation

INFOID:000000003887343

REMOVAL

WARNING:

Never drain engine coolant when the engine is hot to avoid the danger of being scalded.

1. Remove engine cover with power tool. Refer to [EM-27, "Exploded View"](#).
2. Remove air cleaner case and air duct. Refer to [EM-29, "Exploded View"](#).
3. Remove electric throttle control actuator as per the following:
 - a. Drain engine coolant, or when water hoses are disconnected, attach plug to prevent engine coolant leakage.

INTAKE MANIFOLD COLLECTOR

[VQ35HR]

< REMOVAL AND INSTALLATION >

CAUTION:

- Perform this step when engine is cold.
- Never spill engine coolant on drive belt.

- Disconnect water hoses from electric throttle control actuator. When engine coolant is not drained from radiator, attach plug to water hoses to prevent engine coolant leakage.
- Disconnect harness connector.
- Loosen mounting bolts in reverse order as shown in the figure.

NOTE:

- When removing only intake manifold collector, move electric throttle control actuator without disconnecting the water hose.
- The figure shows the electric throttle control actuator (bank 1) viewed from the air duct side.
- Viewed from the air duct side, order of loosening mounting bolts of electric throttle control actuator (bank 2) is the same as that of the electric throttle control actuator (bank 1).

CAUTION:

Handle carefully to avoid any impact to electric throttle control actuator.

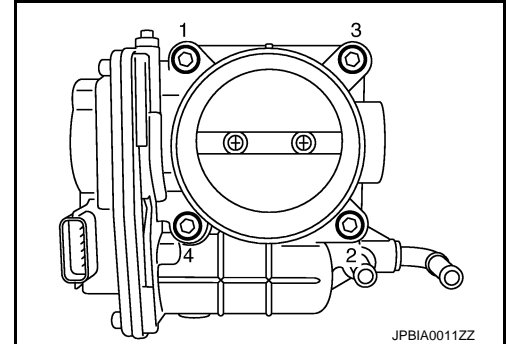

- Disconnect vacuum hose, PCV hose and EVAP hose from intake manifold collector.
- Remove EVAP canister purge volume control solenoid valve and EVAP tube assembly from intake manifold collector.
- Loosen mounting bolts and nuts with power tool in the reverse order as shown in the figure to remove intake manifold collector.

← : Engine front

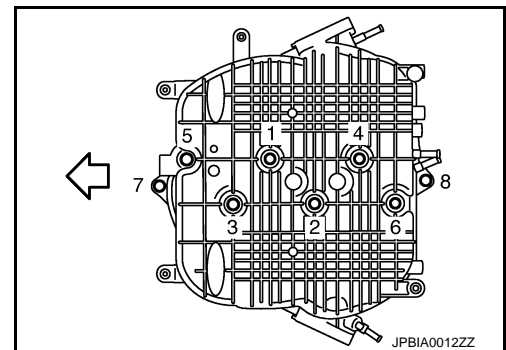

INSTALLATION

Note the following item, and install in the reverse order of removal.

INTAKE MANIFOLD COLLECTOR

- If stud bolts were removed, install them and tighten to the specified torque below.

: 10.8 N·m (1.1 kg-m, 8 ft-lb)

- Tighten mounting bolts and nuts in numerical order as shown in the figure.

← : Engine front

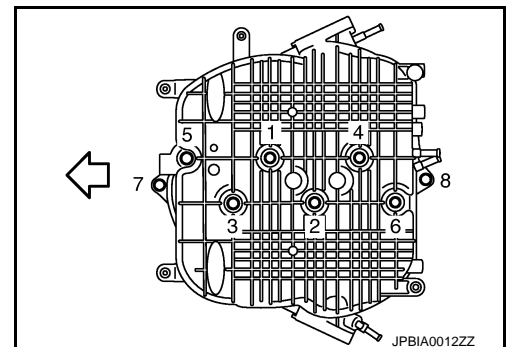

WATER HOSE

- Insert hose by 27 to 32 mm (1.06 to 1.26 in) from connector end.
- Clamp hose at location of 3 to 7 mm (0.12 to 0.28 in) from hose end.

ELECTRIC THROTTLE CONTROL ACTUATOR (BANK 1 AND BANK 2)

INTAKE MANIFOLD COLLECTOR

[VQ35HR]

< REMOVAL AND INSTALLATION >

- Tighten in numerical order as shown in the figure.

NOTE:

- The figure shows the electric throttle control actuator (bank 1) viewed from the air duct side.
- Viewed from the air duct side, order of tightening mounting bolts of electric throttle control actuator (bank 2) is the same as that of the electric throttle control actuator (bank 1).
- Perform the "Throttle Valve Closed Position Learning" when harness connector of electric throttle control actuator is disconnected. Refer to [EC-25, "THROTTLE VALVE CLOSED POSITION LEARNING : Description"](#).
- Perform the "Idle Air Volume Learning" and "Throttle Valve Closed Position Learning" when electric throttle control actuator is replaced. Refer to [EC-25, "IDLE AIR VOLUME LEARNING : Description"](#) and [EC-25, "THROTTLE VALVE CLOSED POSITION LEARNING : Description"](#).

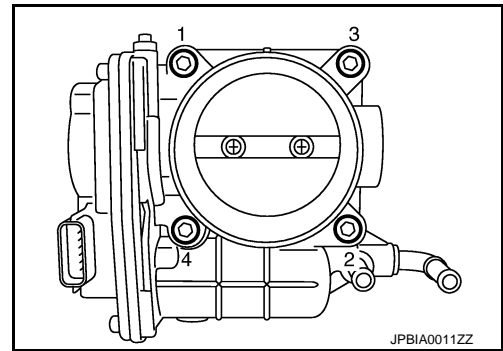

A

EM

C

D

E

F

G

H

I

J

K

L

M

N

O

P

INTAKE MANIFOLD

< REMOVAL AND INSTALLATION >

[VQ35HR]

INTAKE MANIFOLD

Exploded View

INFOID:000000003887344

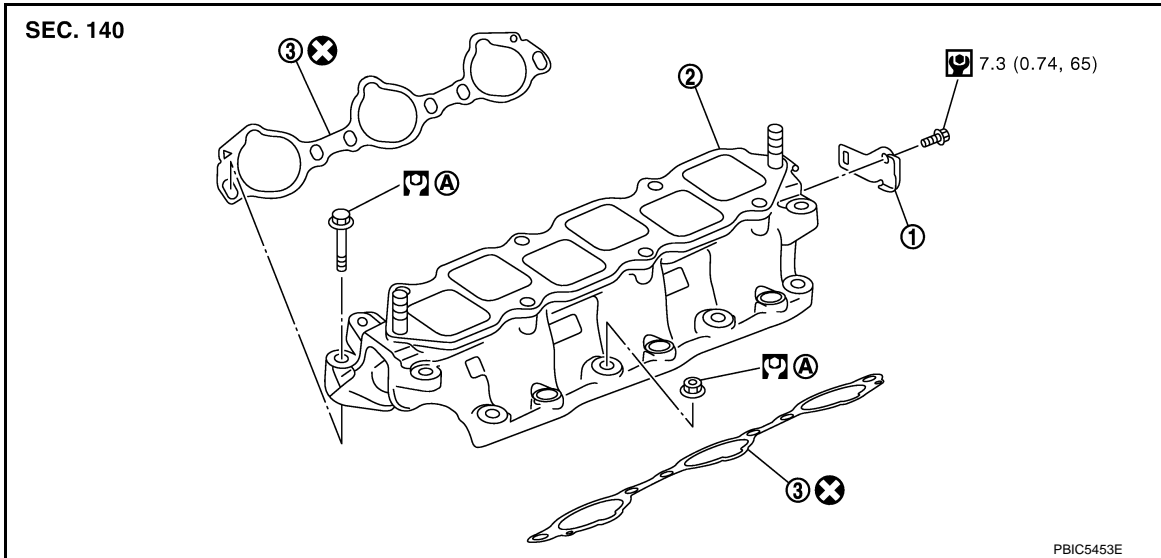

1. Harness bracket 2. Intake manifold 3. Gasket

A. Refer to [EM-34](#)

Refer to [GI-4, "Components"](#) for symbols in the figure.

Removal and Installation

INFOID:000000003887345

REMOVAL

1. Release fuel pressure. Refer to [EC-567, "Inspection"](#).
2. Remove intake manifold collector. Refer to [EM-31, "Exploded View"](#).
3. Remove fuel tube and fuel injector assembly. Refer to [EM-40, "Exploded View"](#).
4. Remove harness bracket.
5. Loosen mounting bolts and nuts in reverse order as shown in the figure to remove intake manifold with power tool.

← : Engine front

CAUTION:

- Cover engine openings to avoid entry of foreign materials.
- Put a mark on the intake manifold and the cylinder head with paint before removal because they need installed in the specified direction.

6. Remove gaskets.

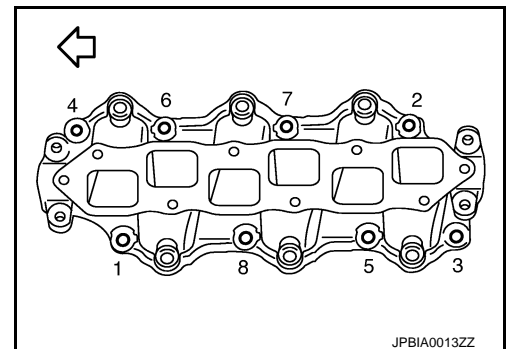

INSTALLATION

Note the following item, and install in the reverse order of removal.

INTAKE MANIFOLD

- If stud bolts were removed, install them and tighten to the specified torque below.

: 10.8 N·m (1.1 kg·m, 8 ft·lb)

INTAKE MANIFOLD

[VQ35HR]

< REMOVAL AND INSTALLATION >

- Tighten all mounting bolts and nuts to the specified torque in two or more steps in numerical order as shown in the figure.

← : Engine front

CAUTION:

Install intake manifold with the marks (put on the intake manifold and the cylinder head before removal) aligned.

1st step:

: 7.4 N·m (0.75 kg·m, 5 ft·lb)

2nd step and after:

: 25.5 N·m (2.6 kg·m, 19 ft·lb)

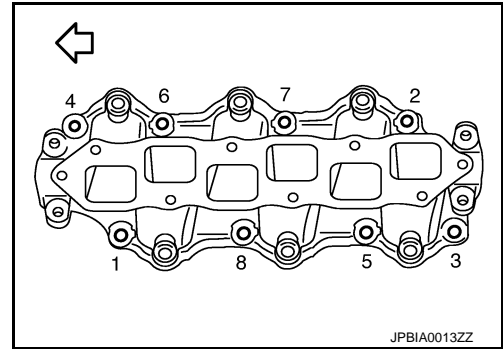

Inspection

INFOID:000000003887346

INSPECTION AFTER REMOVAL

Surface Distortion

- Check the surface distortion of the intake manifold mating surface with a straightedge (A) and a feeler gauge (B).

Limit : Refer to [EM-143, "Intake Manifold"](#).

- If it exceeds the limit, replace intake manifold.

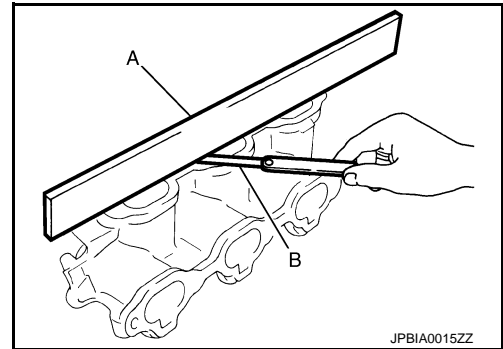

EXHAUST MANIFOLD

< REMOVAL AND INSTALLATION >

[VQ35HR]

EXHAUST MANIFOLD

Exploded View

INFOID:000000003887347

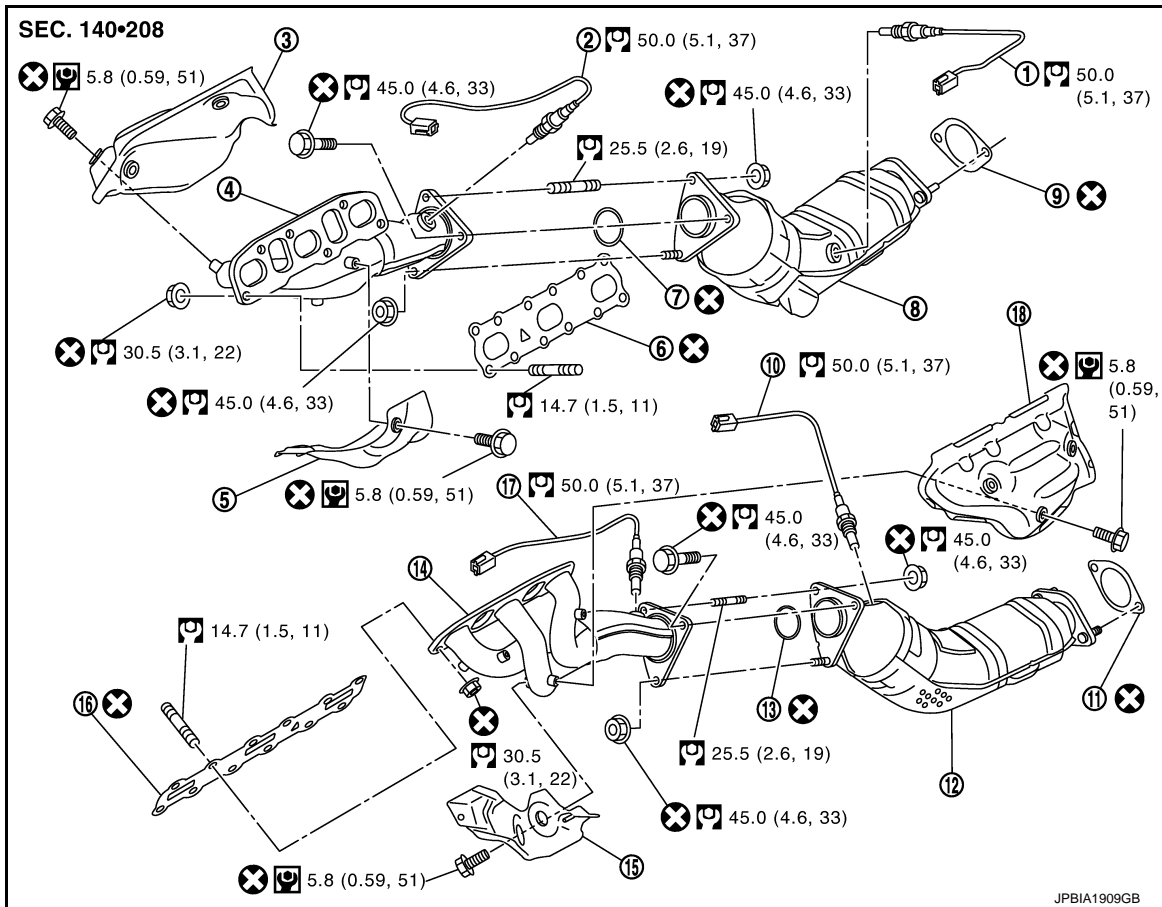

- | | | |
|-------------------------------------|--------------------------------------|------------------------------------|
| 1. Heated oxygen sensor 2 (bank 1) | 2. Air fuel ratio sensor 1 (bank 1) | 3. Exhaust manifold cover (upper) |
| 4. Exhaust manifold (bank 1) | 5. Exhaust manifold cover (lower) | 6. Gasket |
| 7. Ring gasket | 8. Three way catalyst (bank 1) | 9. Gasket |
| 10. Heated oxygen sensor 2 (bank 2) | 11. Gasket | 12. Three way catalyst (bank 2) |
| 13. Ring gasket | 14. Exhaust manifold (bank 2) | 15. Exhaust manifold cover (lower) |
| 16. Gasket | 17. Air fuel ratio sensor 1 (bank 2) | 18. Exhaust manifold cover (upper) |

Refer to [GI-4, "Components"](#) for symbols in the figure.

Removal and Installation

INFOID:000000003887348

REMOVAL

WARNING:

Perform the work when the exhaust and cooling system have completely cooled down.

NOTE:

When removing bank 1 side parts only, step 2, 5 and 10 are unnecessary.

1. Remove engine undercover with power tool.
2. Drain engine coolant. Refer to [CO-8, "Draining"](#).
3. Remove engine cover with power tool. Refer to [EM-27, "Exploded View"](#).
4. Remove air cleaner case and air duct. Refer to [EM-29, "Exploded View"](#).
5. Remove heater pipe and water hose. Refer to [CO-24, "Exploded View"](#).
6. Remove exhaust front tube. Refer to [EX-5, "Exploded View"](#).
7. Disconnect heated oxygen sensor 2 harness connectors (bank 1 and bank 2) and remove harness clip.

EXHAUST MANIFOLD

[VQ35HR]

< REMOVAL AND INSTALLATION >

8. Using heated oxygen sensor wrench [SST: KV10114400 (J-38365)] (C), removal heated oxygen sensor 2.

- A : Bank 2
 B : Bank 1
 ⇐ : Vehicle front

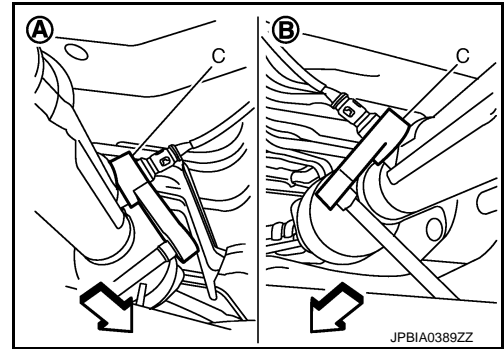

9. Remove three way catalysts (bank 1 and bank 2).
 10. Disconnect steering lower joint at power steering gear assembly side, and release steering lower shaft.
 11. Disconnect air fuel ratio sensor 1 harness connectors (bank 1 and bank 2) and remove harness clip.
 12. Using the heated oxygen sensor wrench [SST: KV10114400 (J-38365)] (C), remove air fuel ratio sensor 1 (bank 1 and bank 2).

- A : Bank 2
 B : Bank 1

CAUTION:

- Be careful not to damage air fuel ratio sensor 1.
- Discard any air fuel ratio sensor 1 which has been dropped onto a hard surface such as a concrete floor. Replace with a new sensor.

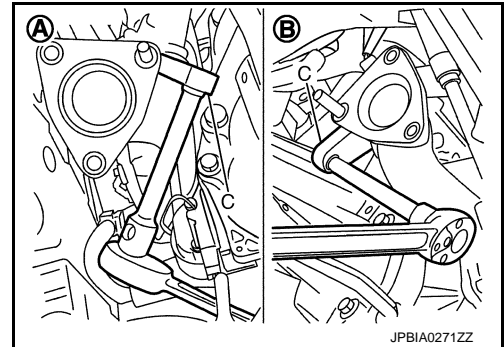

13. Remove exhaust manifold cover (upper) (bank 1 and bank 2).
 14. Loosen mounting nuts in the reverse order as shown in the figure to remove exhaust manifold.

- A : Bank 1
 B : Bank 2
 ⇐ : Engine front

NOTE:

Disregard the numerical order No. 7 and 8 in removal.

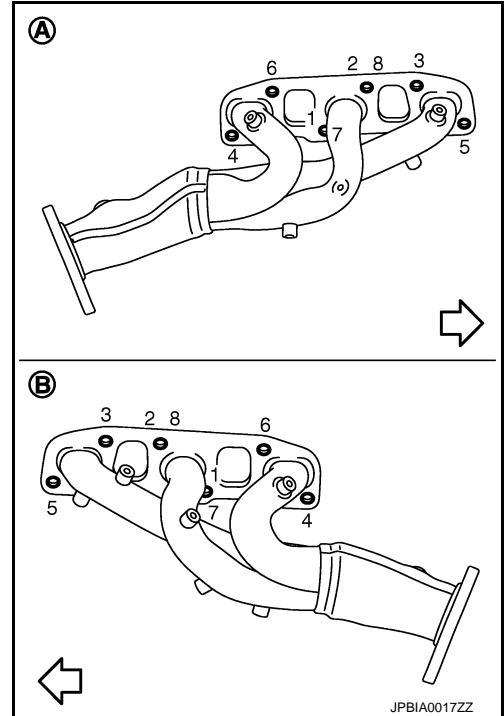

15. Remove gaskets.

CAUTION:

Cover engine openings to avoid entry of foreign materials.

INSTALLATION

Note the following item, and install in the reverse order of removal.

EXHAUST MANIFOLD

[VQ35HR]

< REMOVAL AND INSTALLATION >

EXHAUST MANIFOLD GASKET

- Install exhaust manifold gasket in direction shown in the figure.
(Follow same procedure for both banks.)

- A : Bank 1
- B : Triangle press
- C : Bank 2
- ⇐ : Engine front

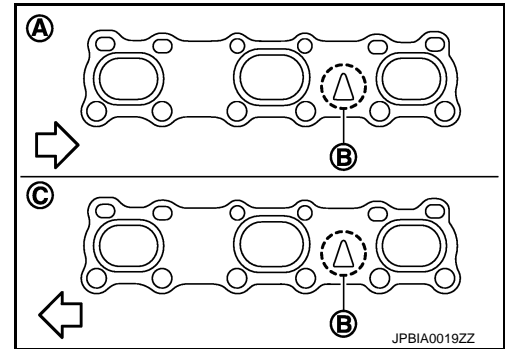

EXHAUST MANIFOLD

- If stud bolts were removed, install them and tighten to the specified torque below.

Tightening torque : Refer to [EM-36, "Exploded View"](#).

- Install exhaust manifold and tighten mounting nuts in numerical order as shown in the figure.

- A : Bank 1
- B : Bank 2
- ⇐ : Engine front

NOTE:

Tighten nuts No. 1 and 2 in two steps. The numerical order No. 7 and 8 shows second step.

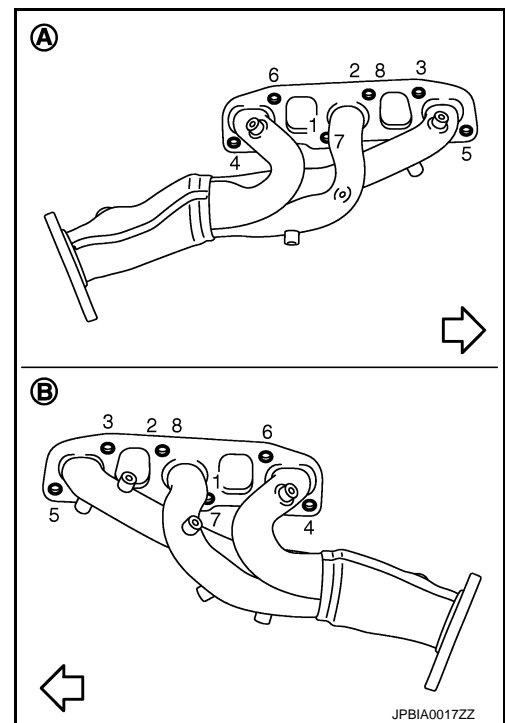

AIR FUEL RATIO SENSOR 1, HEATED OXYGEN SENSOR 2

CAUTION:

- Before installing a new sensors, clean exhaust system threads using heated oxygen sensor thread cleaner tool (commercial service tool: J-43897-18 or J-43897-12) and apply anti-seize lubricant.
- Never over torque sensors. Doing so may cause damage to sensors, resulting in the "MIL" coming on.

Inspection

INFOID:000000003887349

INSPECTION AFTER REMOVAL

Surface Distortion

EXHAUST MANIFOLD

[VQ35HR]

< REMOVAL AND INSTALLATION >

- Check the surface distortion of the exhaust manifold mating surface with a straightedge (A) and a feeler gauge (B).

Limit : Refer to [EM-143. "Exhaust Manifold"](#).

- If it exceeds the limit, replace exhaust manifold.

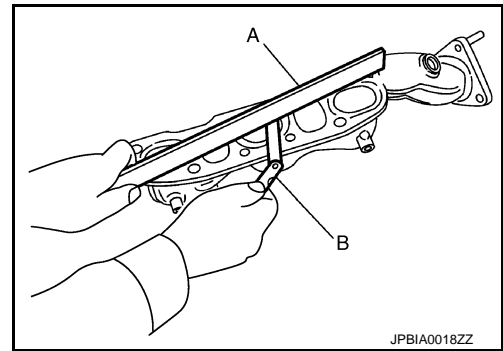

A

EM

C

D

E

F

G

H

I

J

K

L

M

N

O

P

FUEL INJECTOR AND FUEL TUBE

< REMOVAL AND INSTALLATION >

[VQ35HR]

FUEL INJECTOR AND FUEL TUBE

Exploded View

INFOID:000000003887350

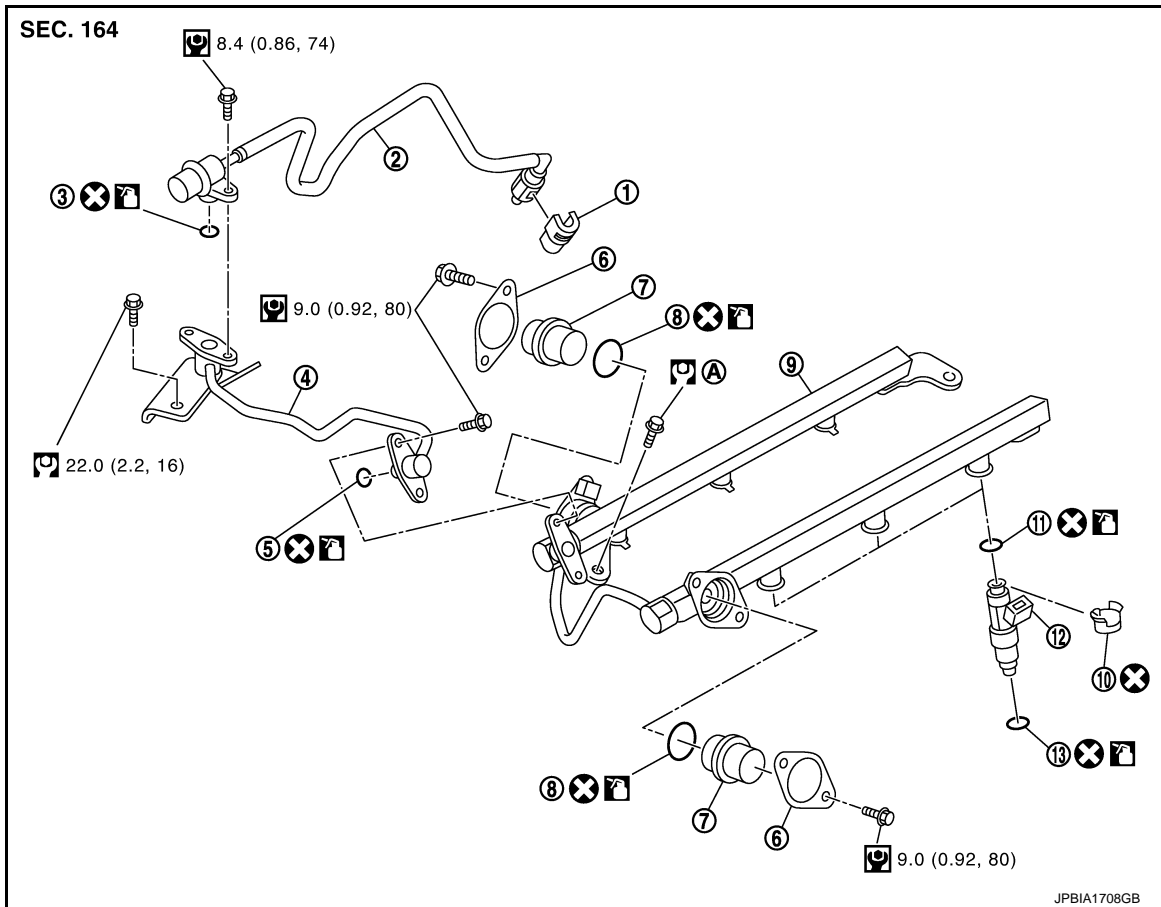

- | | | |
|------------------------|---------------------------------|--------------------|
| 1. Quick connector cap | 2. Fuel feed hose (with damper) | 3. O-ring |
| 4. Fuel sub tube | 5. O-ring | 6. Fuel damper cap |
| 7. Fuel damper | 8. O-ring | 9. Fuel tube |
| 10. Clip | 11. O-ring (black) | 12. Fuel injector |
| 13. O-ring (green) | | |

A. Refer to [EM-40](#)

Refer to [GI-4, "Components"](#) for symbols in the figure.

CAUTION:

Never remove or disassemble parts unless instructed as shown in the figure.

Removal and Installation

INFOID:000000003887351

REMOVAL

WARNING:

- Put a "CAUTION: FLAMMABLE" sign in the workshop.
- Be sure to work in a well ventilated area and furnish workshop with a CO₂ fire extinguisher.
- Never smoke while servicing fuel system. Keep open flames and sparks away from the work area.
- Never drain engine coolant when the engine is hot to avoid the danger of being scalded.

1. Release fuel pressure. Refer to [EC-567, "Inspection"](#).
2. Disconnect battery cable from the negative terminal. Refer to [PG-120, "Exploded View"](#).
3. Remove engine cover with power tool. Refer to [EM-27, "Exploded View"](#).
4. Remove air cleaner case and air duct. Refer to [EM-29, "Exploded View"](#).

FUEL INJECTOR AND FUEL TUBE

< REMOVAL AND INSTALLATION >

[VQ35HR]

5. Remove intake manifold collector. Refer to [EM-31, "Exploded View"](#).
6. Remove fuel feed hose (with damper) (1) from fuel sub-tube (2) and remove harness bracket (3).

⇐ : Engine front

NOTE:

There is no fuel return route.

CAUTION:

- While hoses are disconnected, plug them to prevent fuel from draining.
- Never separate damper and hose.

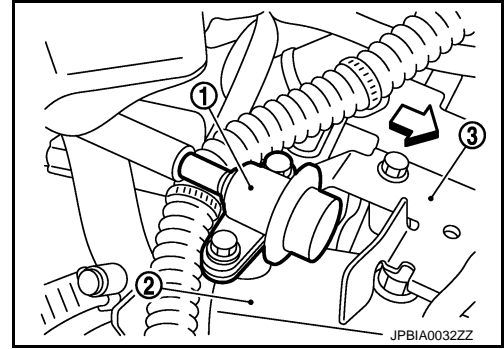

7. When separating fuel feed hose (with damper) and centralized under-floor piping connection, disconnect quick connector as per the following:

- a. Remove quick connector cap (2) from quick connector connection on right member side.
- b. Disconnect fuel feed hose (with damper) (1) from bracket hose clamp.

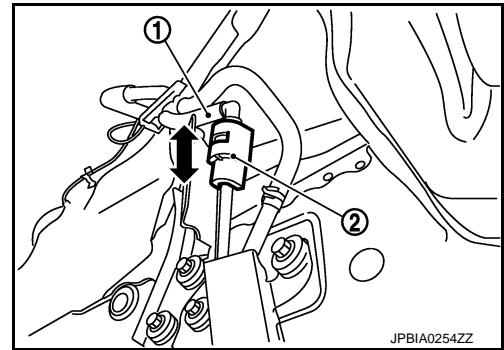

- c. Push in retainer tabs (2).
- d. Draw and pull out quick connector (1) straight from centralized under-floor piping (3).

CAUTION:

- Pull quick connector holding position (A) as shown in the figure.
- Never pull with lateral force applied. O-ring inside quick connector may be damaged.
- Prepare container and cloth beforehand as fuel will leak out.
- Avoid fire and sparks.
- Keep parts away from heat source. Especially, be careful when welding is performed around them.
- Never expose parts to battery electrolyte or other acids.
- Never bend or twist connection between quick connector and fuel feed hose (with damper) during installation/removal.
- To keep the connecting portion clean and to avoid damage and foreign materials, cover them completely with plastic bags, etc. (A) or something similar.

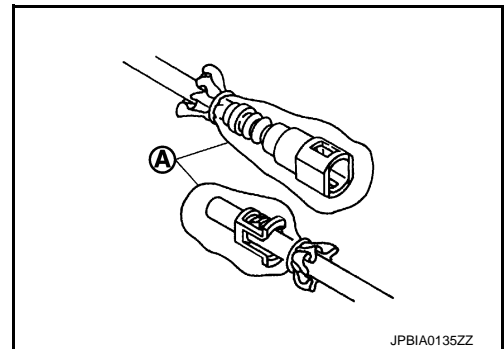
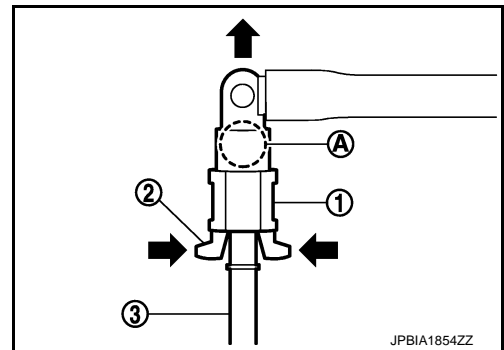

8. Remove fuel sub tube mounting bolt.
9. Disconnect harness connector from fuel injector.

FUEL INJECTOR AND FUEL TUBE

[VQ35HR]

< REMOVAL AND INSTALLATION >

10. Loosen mounting bolts in reverse order as shown in the figure, and remove fuel tube and fuel injector assembly.

← : Engine front

CAUTION:

Never tilt fuel tube, or remaining fuel in pipes may flow out from pipes.

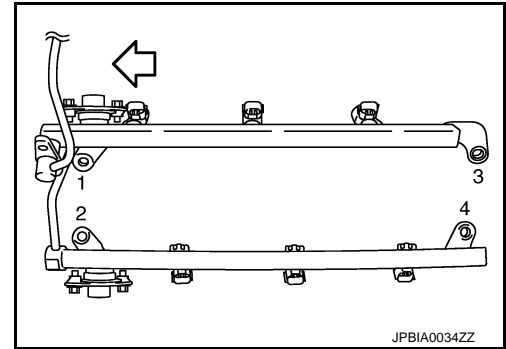

11. Remove fuel injector (2) from fuel tube (4) as per the following:

3 : O-ring

A : Installed condition

B : Clip mounting groove

- Open and remove clip (1).
- Remove fuel injector from fuel tube by pulling straight.

CAUTION:

- Be careful with remaining fuel that may go out from fuel tube.
- Be careful not to damage injector nozzles during removal.
- Never bump or drop fuel injector.
- Never disassemble fuel injector.

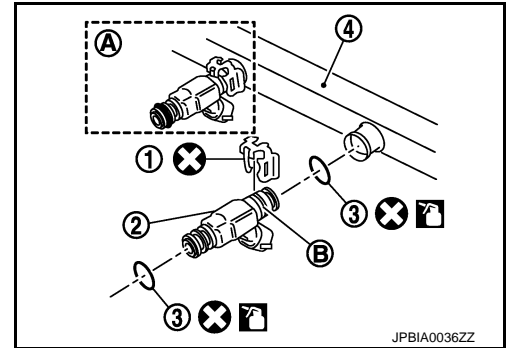

12. Remove fuel sub-tube and fuel damper, if necessary.

INSTALLATION

1. Install fuel damper (4) as per the following:

- Install new O-ring (2) to fuel tube (1) as shown. When handling new O-ring, be careful of the following caution:

CAUTION:

- Handle O-ring with bare hands. Never wear gloves.
- Lubricate O-ring with new engine oil.
- Never clean O-ring with solvent.
- Check that O-ring and its mating part are free of foreign material.
- When installing O-ring, be careful not to scratch it with tool or fingernails. Also be careful not to twist or stretch O-ring. If O-ring was stretched while it was being attached, never insert it quickly into fuel tube.
- Insert new O-ring straight into fuel tube. Never twist it.

- Install spacer (3) to fuel damper.
- Insert fuel damper straight into fuel tube.

CAUTION:

- Insert straight, checking sure that the axis is lined up.
- Insert fuel damper at 130 N (13.3 kg, 29.2 lb) or less to prevent damage to the parts.
- Insert fuel damper until (B) is touching (A) of fuel tube.

- Tighten bolts evenly in turn.
 - After tightening bolts, check that there is no gap between fuel damper cap (5) and fuel tube.

2. Install fuel sub-tube.

- When handling new O-rings, be careful of the following caution:

CAUTION:

- Handle O-ring with bare hands. Never wear gloves.
- Lubricate O-ring with new engine oil.

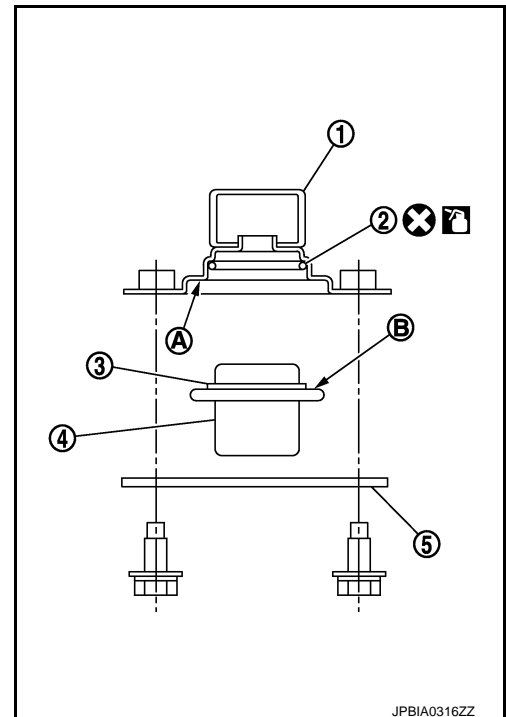

FUEL INJECTOR AND FUEL TUBE

< REMOVAL AND INSTALLATION >

[VQ35HR]

- Never clean O-ring with solvent.
 - Check that O-ring and its mating part are free of foreign material.
 - When installing O-ring, be careful not to scratch it with tool or fingernails. Also be careful not to twist or stretch O-ring. If O-ring was stretched while it was being attached, never insert it quickly into fuel tube.
 - Insert new O-ring straight into fuel tube. Never decenter or twist it.
3. Install new O-rings to fuel injector, paying attention to the following.
- CAUTION:**
- Upper and lower O-ring are different. Be careful not to confuse them.

Fuel tube side : Black

Nozzle side : Green

- Handle O-ring with bare hands. Never wear gloves.
- Lubricate O-ring with new engine oil.
- Never clean O-ring with solvent.
- Check that O-ring and its mating part are free of foreign material.
- When installing O-ring, be careful not to scratch it with tool or fingernails. Also be careful not to twist or stretch O-ring. If O-ring was stretched while it was being attached, never insert it quickly into fuel tube.
- Insert O-ring straight into fuel injector. Never decenter or twist it.

4. Install fuel injector to fuel tube as per the following:

- a. Insert clip (3) into clip mounting groove (D) on fuel injector (5).

2 : O-ring (Black)

4 : O-ring (Green)

CAUTION:

- Never reuse clip. Replace it with a new one.
 - Be careful to keep clip from interfering with O-ring. If interference occurs, replace O-ring.
- b. Insert fuel injector into fuel tube (1) with clip attached.
- Insert it while matching it to the axial center.
 - Insert fuel injector so that protrusion (A) of fuel tube matches cutout (B) of clip.
 - Check that fuel tube flange (E) is securely fixed in flange fixing groove (C) on clip.
- c. Check that installation is complete by checking that fuel injector does not rotate or come off.
- Check that protrusions of fuel injectors are aligned with cut-outs of clips after installation.

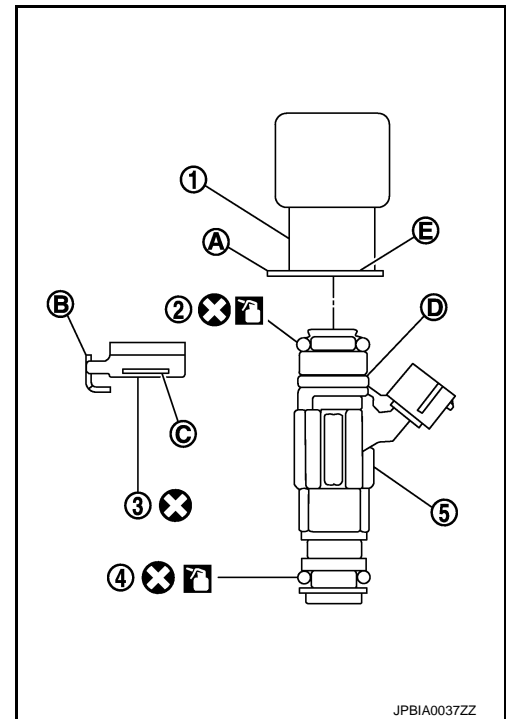

5. Install fuel tube and fuel injector assembly to intake manifold.

CAUTION:

Be careful not to let tip of injector nozzle come in contact with other parts.

FUEL INJECTOR AND FUEL TUBE

[VQ35HR]

< REMOVAL AND INSTALLATION >

- Tighten mounting bolts in two steps in numerical order as shown in the figure.

← : Engine front

- 🔩 **1st step** : 10.1 N-m (1.0 kg-m, 7 ft-lb)
- 🔩 **2nd step** : 23.6 N-m (2.4 kg-m, 17 ft-lb)

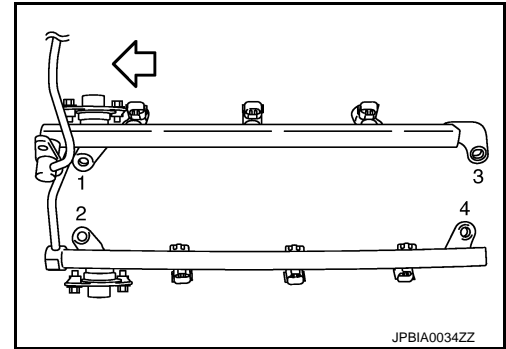

6. Connect injector sub-harness.
7. Install fuel sub tube mounting bolt.
8. Connect fuel feed hose (with damper).
 - Handling procedure of O-ring is the same as that of fuel damper and fuel sub-tube.
 - Insert fuel damper straight into fuel sub-tube.
 - Tighten mounting bolts evenly in turn.
 - After tightening mounting bolts, check that there is no gap between flange and fuel sub-tube.
9. Connect quick connector between fuel feed hose (with damper) and centralized under-floor piping connection as per the following:
 - a. Check no foreign substances are deposited in and around centralized under-floor piping and quick connector, and no damage on them.
 - b. Thinly apply new engine oil around centralized under-floor piping from tip end to spool end.
 - c. Align center to insert quick connector straightly into centralized under-floor piping.
 - Visually confirm that the two retainer tabs (A) are connected to the quick connector (B).

CAUTION:

- **Carefully align center to avoid inclined insertion to prevent damage to O-ring inside quick connector.**
- **Insert until you hear a “click” sound and actually feel the engagement.**
- **To avoid misidentification of engagement with a similar sound, be sure to perform the next step.**

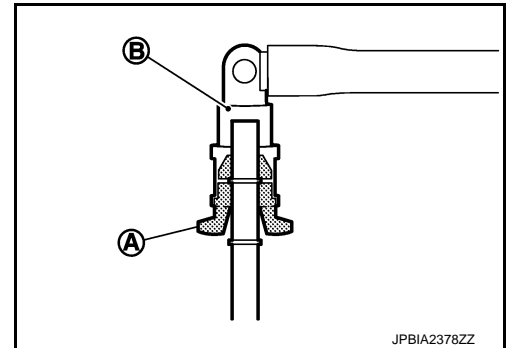

- d. Pull quick connector by hand holding position (A). Check it is completely engaged (connected) so that it does not come out from centralized under-floor piping (1).

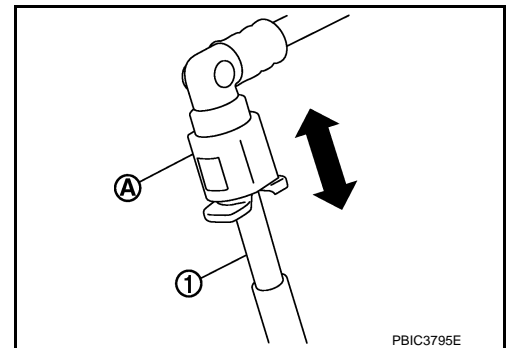

FUEL INJECTOR AND FUEL TUBE

[VQ35HR]

< REMOVAL AND INSTALLATION >

e. Install quick connector cap (3) to quick connector connection.

- 1 : Centralized under-floor piping
- 2 : Fuel feed hose
- B : Under view

- Install quick connector cap with arrow (A) on surface facing the direction of quick connector (fuel feed hose side).

CAUTION:

If quick connector cap cannot be installed smoothly, quick connector may have not be installed correctly. Check the connection again.

10. Install in the reverse order of removal after this step.

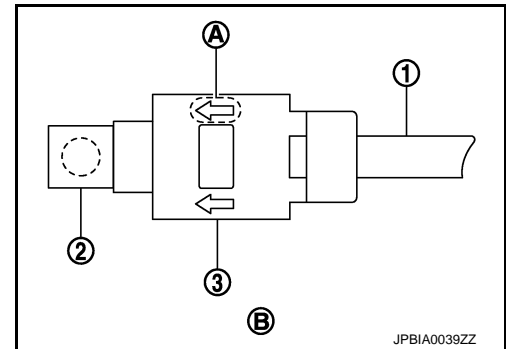

Inspection

INFOID:000000003887352

INSPECTION AFTER INSTALLATION

Check on Fuel Leakage

1. Turn ignition switch "ON" (with the engine stopped). With fuel pressure applied to fuel piping, check there are no fuel leakage at connection points.

NOTE:

Use mirrors for checking at points out of clear sight.

2. Start the engine. With engine speed increased, check again that there are no fuel leakage at connection points.

CAUTION:

Never touch the engine immediately after stopped, as the engine becomes extremely hot.

OIL PAN (LOWER) AND OIL STRAINER

< REMOVAL AND INSTALLATION >

[VQ35HR]

OIL PAN (LOWER) AND OIL STRAINER

Exploded View

INFOID:000000003887353

2WD models

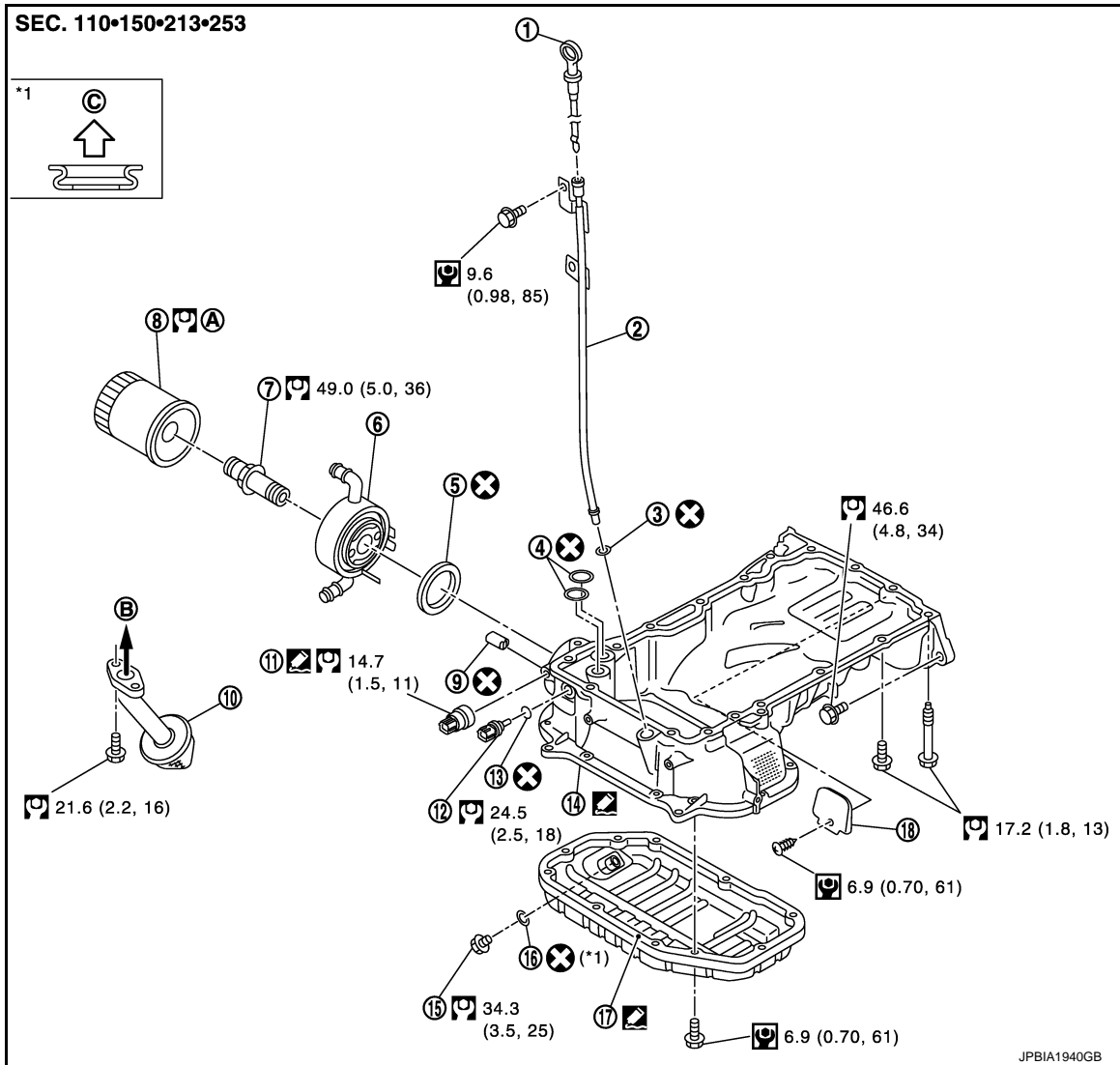

- | | | |
|----------------------------------|--------------------------|----------------------------|
| 1. Oil level gauge | 2. Oil level gauge guide | 3. O-ring |
| 4. O-ring | 5. O-ring | 6. Oil cooler |
| 7. Connector bolt | 8. Oil filter | 9. Relief valve |
| 10. Oil strainer | 11. Oil pressure switch | 12. Oil temperature sensor |
| 13. Washer | 14. Oil pan (upper) | 15. Drain plug |
| 16. Drain plug washer | 17. Oil pan (lower) | 18. Rear plate cover |
| A. Refer to LU-9 | B. To oil pump | C. Oil pan side |

Refer to [GI-4, "Components"](#) for symbols in the figure.

AWD

OIL PAN (LOWER) AND OIL STRAINER

< REMOVAL AND INSTALLATION >

[VQ35HR]

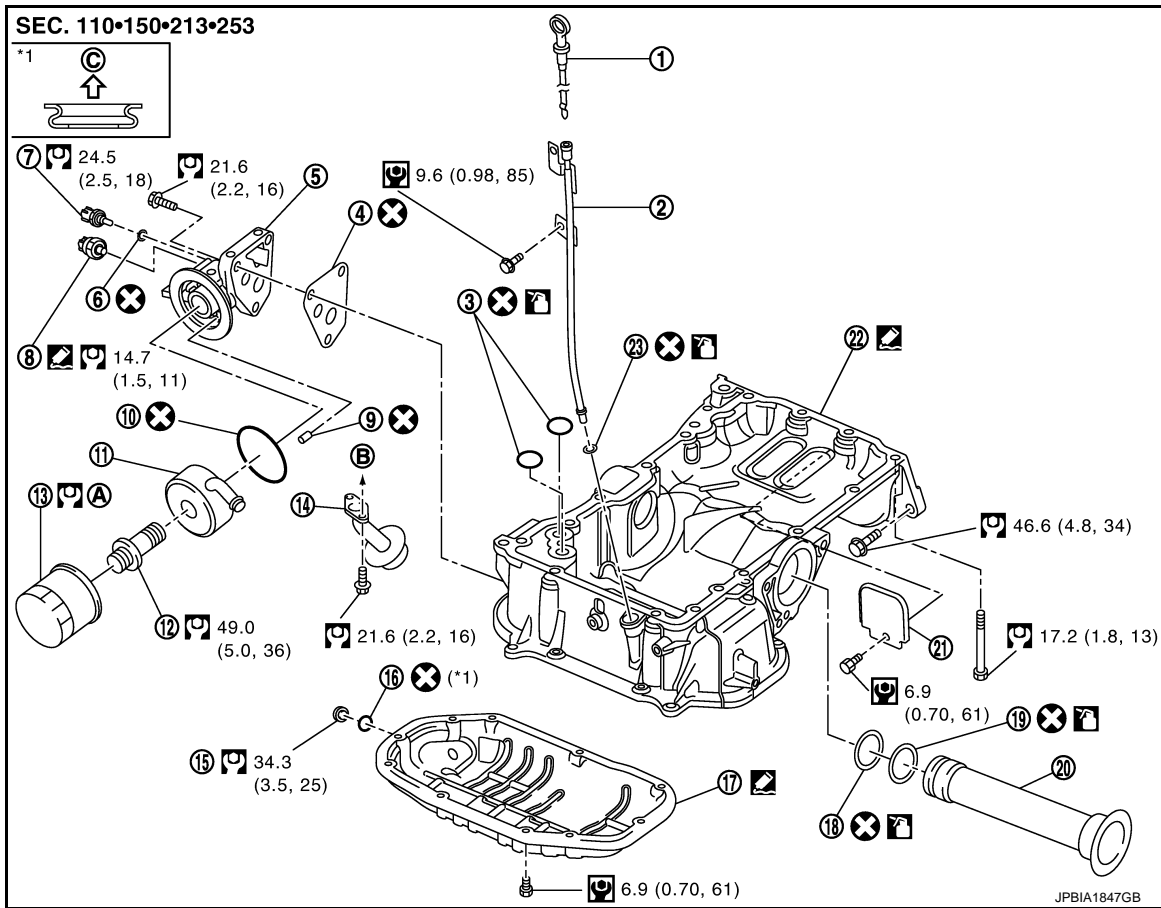

- | | | |
|----------------------------------|--------------------------|----------------------|
| 1. Oil level gauge | 2. Oil level gauge guide | 3. O-ring |
| 4. Gasket | 5. Oil filter bracket | 6. Washer |
| 7. Oil temperature sensor | 8. Oil pressure sensor | 9. Relief valve |
| 10. O-ring | 11. Oil cooler | 12. Connector bolt |
| 13. Oil filter | 14. Oil strainer | 15. Drain plug |
| 16. Oil pan drain plug | 17. Oil pan (lower) | 18. O-ring (small) |
| 19. O-ring (large) | 20. Axle pipe | 21. Rear plate cover |
| 22. Oil pan (upper) | 23. O-ring | |
| A. Refer to LU-9 | B. To oil pump | C. Oil pan side |

Refer to [GI-4, "Components"](#) for symbols in the figure.

Removal and Installation

INFOID:000000003887355

REMOVAL

WARNING:

To avoid the danger of being scalded, never drain engine oil when engine is hot.

1. Remove engine undercover with power tool.
2. Drain engine oil. Refer to [LU-8, "Draining"](#).
3. Remove oil pan (lower) as per the following:

OIL PAN (LOWER) AND OIL STRAINER

[VQ35HR]

< REMOVAL AND INSTALLATION >

- a. Loosen mounting bolts in reverse order as shown in the figure to remove.

⇐ : Engine front

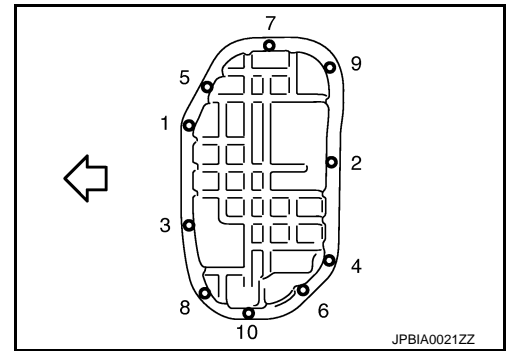

- b. Insert the seal cutter [SST: KV10111100 (J-37228)] (A) between oil pan (upper) and oil pan (lower).

CAUTION:

- Be careful not to damage the mating surfaces.
- Never insert a screwdriver, this will damage the mating surfaces.

- c. Slide the seal cutter by tapping on the side of tool with a hammer. Remove oil pan (lower).

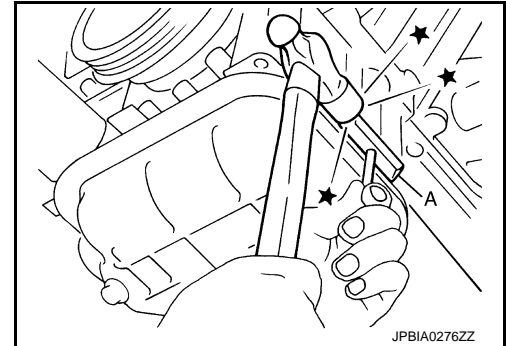

4. Remove oil strainer.

INSTALLATION

1. Install oil strainer.
2. Install oil pan (lower) as per the following:
a. Use scraper (A) to remove old liquid gasket from mating surfaces.
 - Remove old liquid gasket from the bolt holes and thread.

CAUTION:

Never scratch or damage the mating surfaces when cleaning off old liquid gasket.

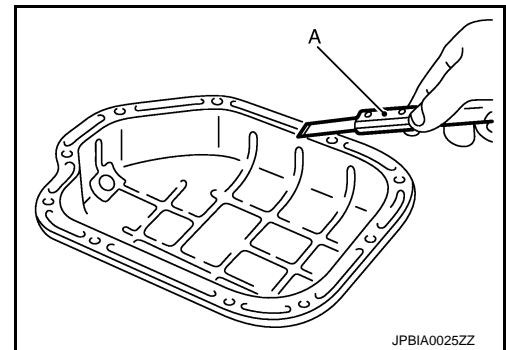

- b. Apply a continuous bead of liquid gasket with the tube presser (commercial service tool) to the oil pan (lower) as shown in the figure.

⇐ : Engine front

a : $\phi 4.0 - 5.0$ mm (0.157 - 0.197 in)

Use Genuine RTV Silicone Sealant or an equivalent. Refer to [GI-15, "Recommended Chemical Products and Sealants"](#).

CAUTION:

Attaching must be done within 5 minutes after coating.

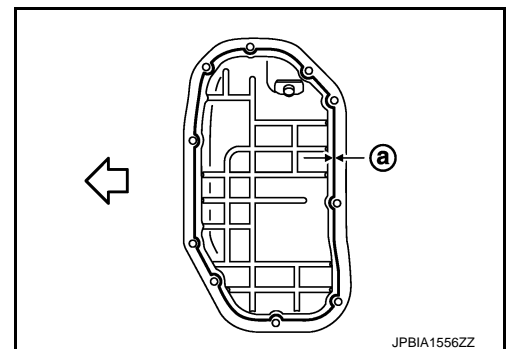

- c. Install oil pan (lower).

OIL PAN (LOWER) AND OIL STRAINER

[VQ35HR]

< REMOVAL AND INSTALLATION >

- Tighten mounting bolts in numerical order as shown in the figure.

⇐ : Engine front

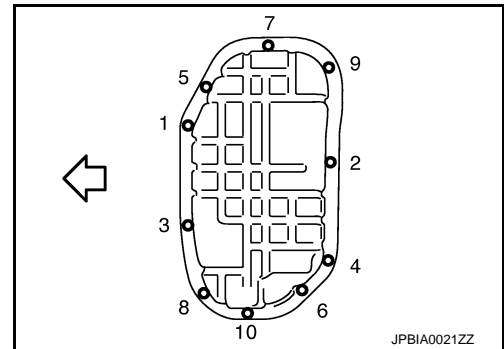

3. Install oil pan drain plug.
 - Refer to the figure of components of former page for installation direction of drain plug washer. Refer to [EM-46, "Exploded View"](#).
4. Install in the reverse order of removal after this step.
NOTE:
At least 30 minutes after oil pan is installed, pour engine oil.

Inspection

INFOID:000000003887356

INSPECTION AFTER REMOVAL

Clean oil strainer if any object attached.

INSPECTION AFTER INSTALLATION

1. Check the engine oil level and adjust engine oil. Refer to [LU-6, "Inspection"](#).
2. Start engine, and check there is no leakage of engine oil.
3. Stop engine and wait for 10 minutes.
4. Check the engine oil level again. Refer to [LU-6, "Inspection"](#).

IGNITION COIL, SPARK PLUG AND ROCKER COVER

< REMOVAL AND INSTALLATION >

[VQ35HR]

IGNITION COIL, SPARK PLUG AND ROCKER COVER

Exploded View

INFOID:000000003887357

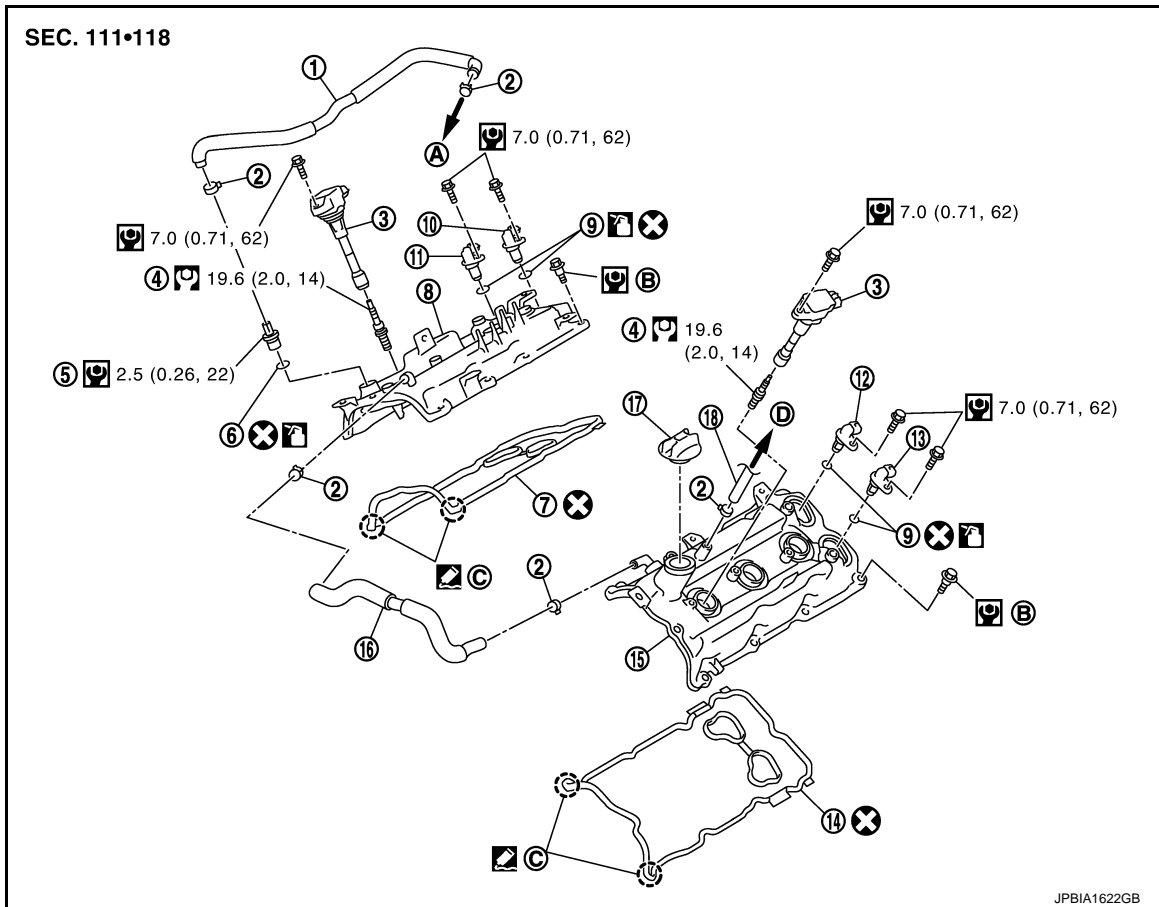

JPBIA1622GB

- | | | |
|---|---|---|
| 1. PCV hose | 2. Clamp | 3. Ignition coil |
| 4. Spark plug | 5. PCV valve | 6. O-ring |
| 7. Rocker cover gasket (bank 1) | 8. Rocker cover (bank 1) | 9. O-ring |
| 10. Camshaft position sensor (PHASE) (bank 1) | 11. Exhaust valve timing control position sensor (bank 1) | 12. Camshaft position sensor (PHASE) (bank 2) |
| 13. Exhaust valve timing control position sensor (bank 2) | 14. Rocker cover gasket (bank 2) | 15. Rocker cover (bank 2) |
| 16. PCV hose | 17. Oil filler cap | 18. PCV hose |
| A. To intake manifold collector | B. Refer to EM-50 | C. Camshaft bracket side |
| D. To air duct | | |

Refer to [GI-4, "Components"](#) for symbols in the figure.

Removal and Installation

INFOID:000000003887358

REMOVAL

- Remove the following parts:
 - Engine cover: Refer to [EM-27, "Exploded View"](#).
 - Air cleaner case and air duct: Refer to [EM-29, "Exploded View"](#).
 - Intake manifold collector: Refer to [EM-31, "Exploded View"](#).
- Disconnect PCV hose from rocker cover.

IGNITION COIL, SPARK PLUG AND ROCKER COVER

< REMOVAL AND INSTALLATION >

[VQ35HR]

3. Remove camshaft position sensor (PHASE) and exhaust valve timing control position sensor. (bank 1 and bank 2)

A : Keep off any magnetic materials

CAUTION:

- Handle carefully to avoid dropping and shocks.
- Never disassemble.
- Never allow metal powder to adhere to magnetic part at sensor tip.
- Never place sensors in a location where they are exposed to magnetism.

4. Remove PCV valve and O-ring from rocker cover, if necessary.
5. Remove oil filler cap from rocker cover, if necessary.
6. Remove ignition coil.

CAUTION:

Never impact ignition coil.

7. Remove harness clips on the rocker cover.
8. Loosen mounting bolts with power tool in reverse order shown in the figure.

← : Engine front

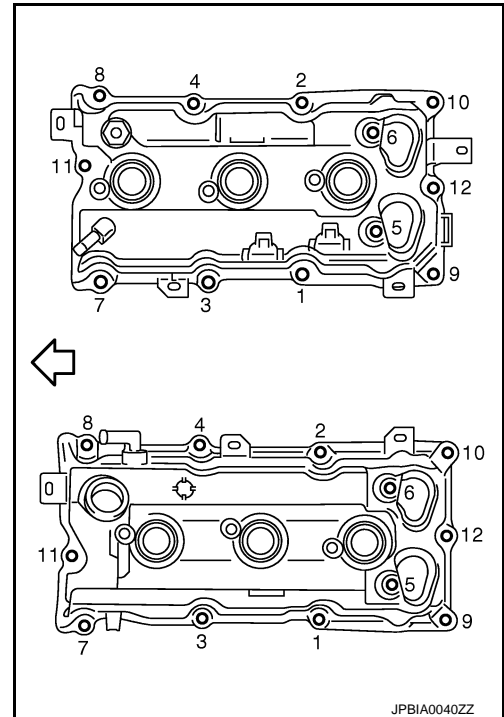
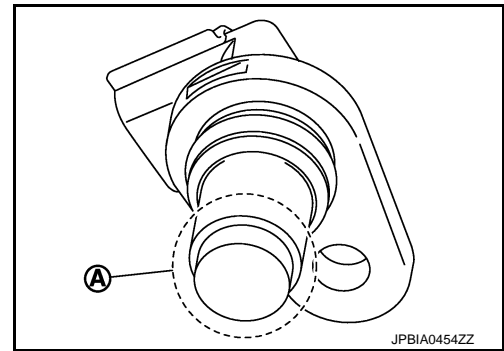

9. Remove rocker cover gasket from rocker cover.
10. Use scraper to remove all traces of liquid gasket from cylinder head and camshaft bracket (No. 1).

CAUTION:

Never scratch or damage the mating surface when cleaning off old liquid gasket.

INSTALLATION

IGNITION COIL, SPARK PLUG AND ROCKER COVER

[VQ35HR]

< REMOVAL AND INSTALLATION >

1. Apply liquid gasket to the position shown in the figure with the following procedure:

- A : Liquid gasket application point
- F : View F
- l : End surface of camshaft bracket (No. 1)
- b : 4 mm (0.16 in)
- c : $\phi 2.5 - 3.5$ mm (0.098 - 0.138 in)
- d : 5 mm (0.20 in)
- g : 10 mm (0.39 in)
- ⇐ : Engine front

Use Genuine RTV silicone sealant or an equivalent. Refer to [GI-15, "Recommended Chemical Products and Sealants"](#).

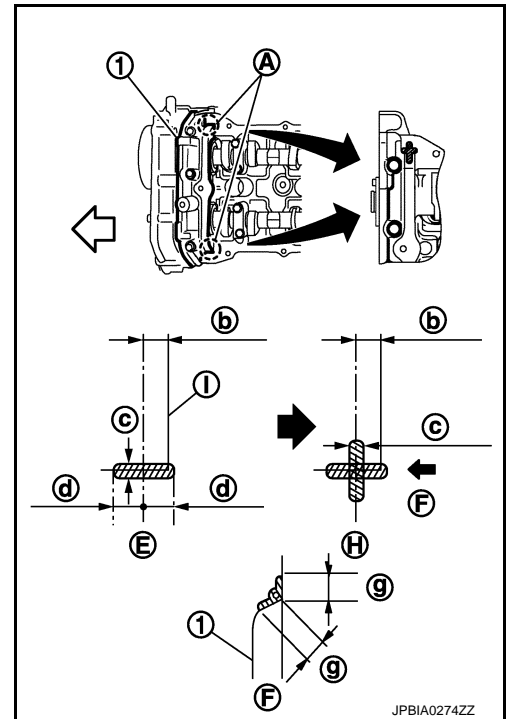

- a. Refer to figure (E) to apply liquid gasket to joint part of camshaft bracket (No. 1) (1) and cylinder head.
- b. Refer to figure (H) to apply liquid gasket in 90 degrees to figure.



JPBIA0274ZZ

2. Install rocker cover gasket to rocker cover.
3. Install rocker cover.
 - Check if rocker cover gasket is not dropped from the installation groove of rocker cover.
4. Tighten bolts in two steps separately in numerical order as shown in the figure.

⇐ : Engine front

-  **1st step : 2.0 N·m (0.2 kg-m, 18 in-lb)**
-  **2nd step : 8.3 N·m (0.85 kg-m, 73 in-lb)**

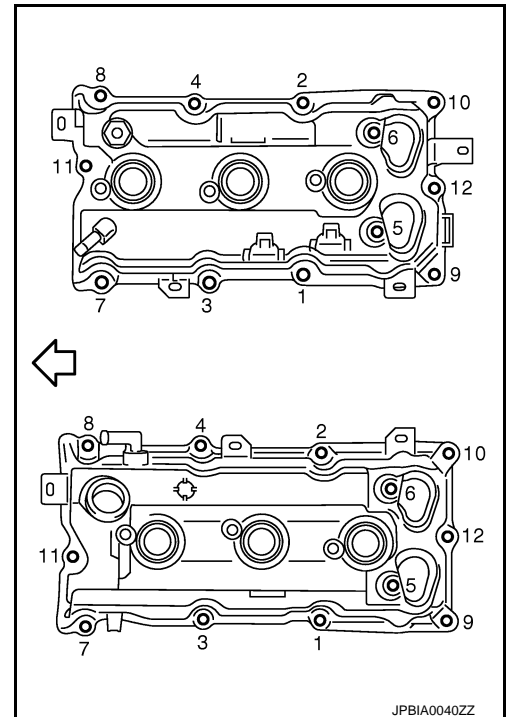

JPBIA0040ZZ

5. Install in the reverse order of removal after this step.

TIMING CHAIN

< REMOVAL AND INSTALLATION >

[VQ35HR]

TIMING CHAIN

Exploded View

INFOID:000000003887359

A

EM

C

D

E

F

G

H

I

J

K

L

M

N

O

P

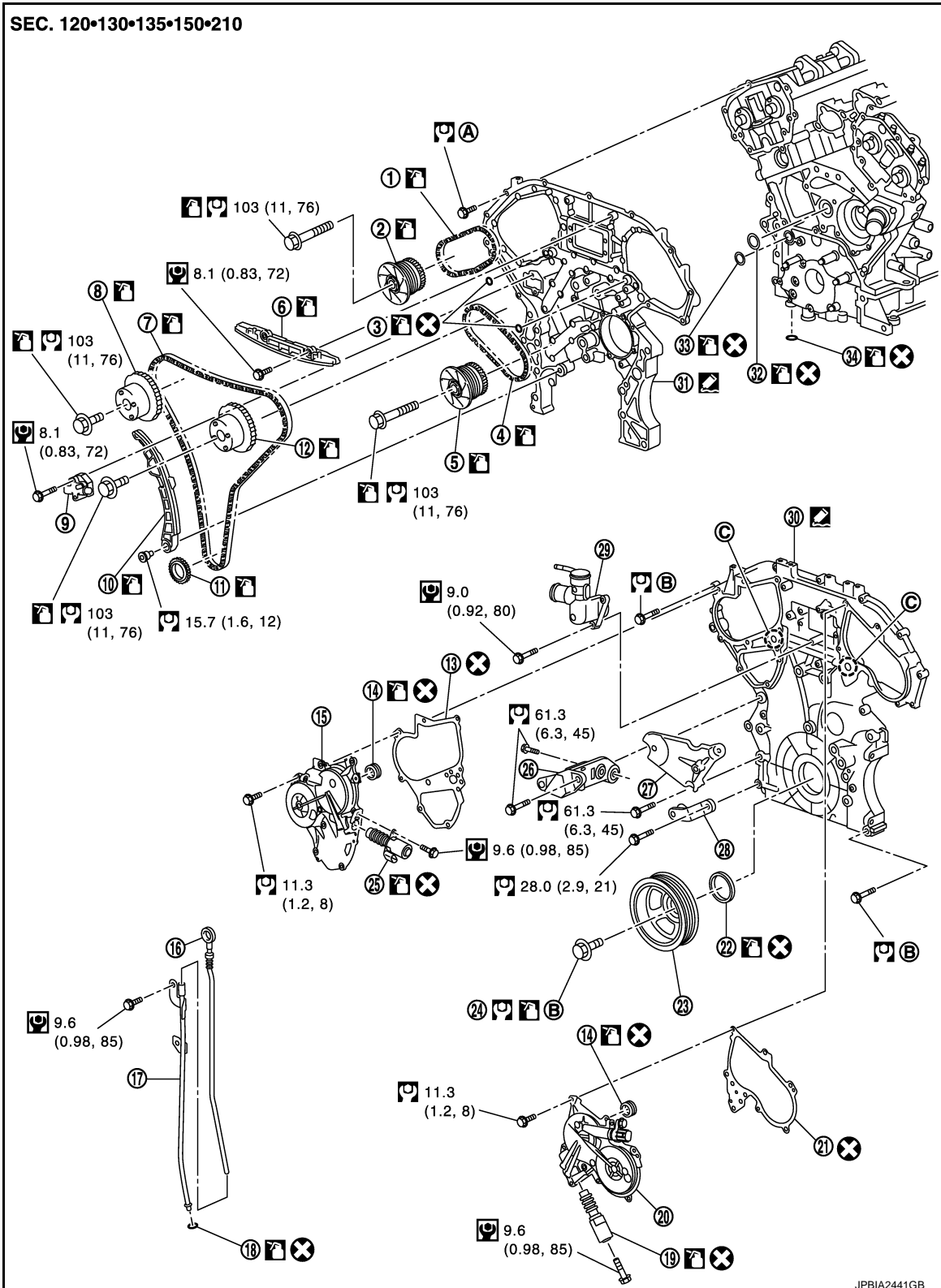

- | | | |
|-----------------------------|----------------------------|-------------------------------------|
| 1. Timing chain (secondary) | 2. Camshaft sprocket (EXH) | 3. O-ring |
| 4. Timing chain (secondary) | 5. Camshaft sprocket (EXH) | 6. Internal chain guide |
| 7. Timing chain (primary) | 8. Camshaft sprocket (INT) | 9. Timing chain tensioner (primary) |

TIMING CHAIN

[VQ35HR]

< REMOVAL AND INSTALLATION >

- | | | |
|---|---|--|
| 10. Slack guide | 11. Crankshaft sprocket | 12. Camshaft sprocket (INT) |
| 13. Valve timing control cover gasket (bank 1) | 14. Seal ring | 15. Valve timing control cover (bank 1) |
| 16. Oil level gauge | 17. Oil level gauge guide | 18. O-ring |
| 19. Intake valve timing control solenoid valve (bank 2) | 20. Valve timing control cover (bank 2) | 21. Valve timing control cover gasket (bank 2) |
| 22. Front oil seal | 23. Crankshaft pulley | 24. Crankshaft pulley bolt |
| 25. Intake valve timing control solenoid valve (bank 1) | 26. Power steering oil pump bracket | 27. Idler pulley bracket |
| 28. Alternator bracket | 29. Water outlet (front) | 30. Front timing chain case |
| 31. Rear timing chain case | 32. O-ring | 33. O-ring |
| 34. O-ring | | |
| A. Refer to EM-97 | B. Refer to EM-54 | C. Oil filter |

Refer to [GI-4, "Components"](#) for symbols in the figure.

Removal and Installation

INFOID:000000003887360

REMOVAL

1. Release the fuel pressure. Refer to [EC-567, "Inspection"](#).
2. Disconnect the battery cable from the negative terminal.
3. Remove engine cover with power tool. Refer to [EM-27, "Exploded View"](#).
4. Remove radiator reservoir tank. Refer to [CO-14, "Exploded View"](#).
5. Remove air duct and air cleaner case assembly. Refer to [EM-29, "Exploded View"](#).
6. Remove engine undercover with power tool.
7. Drain engine coolant from radiator. Refer to [CO-8, "Draining"](#).
CAUTION:
 - Perform this step when the engine is cold.
 - Never spill engine coolant on drive belt.
8. Remove radiator hose (upper and lower). Refer to [CO-14, "Exploded View"](#).
9. Drain engine oil. Refer to [LU-8, "Draining"](#).
CAUTION:
 - Perform this step when the engine is cold.
 - Never spill engine oil on drive belt.
10. Remove drive belt. Refer to [EM-15, "Exploded View"](#).
11. Remove radiator cooling fan assembly. Refer to [CO-14, "Exploded View"](#).
12. Separate engine harnesses removing their brackets from front timing chain case.
13. Remove intake manifold collector. Refer to [EM-31, "Exploded View"](#).
14. Remove intake manifold. Refer to [EM-34, "Exploded View"](#).
15. Remove oil level gauge and oil level gauge guide.
16. Remove A/C compressor from bracket with piping connected, and temporarily secure it aside. Refer to [HA-38, "Exploded View"](#).
17. Remove power steering oil pump from bracket with piping connected, and temporarily secure it aside. Refer to [ST-47, "VQ35HR : Exploded View"](#).
18. Remove power steering oil pump bracket.
19. Remove idler pulley, auto tensioner and bracket.
20. Remove alternator and alternator bracket. Refer to [CHG-25, "VQ35HR : Exploded View"](#).
21. Remove water outlet (front) and water piping. Refer to [CO-24, "Exploded View"](#).
22. Remove valve timing control covers (bank 1 and bank 2) and gasket as per the following:
 - a. Disconnect valve timing control harness connector.

TIMING CHAIN

< REMOVAL AND INSTALLATION >

[VQ35HR]

b. Loosen mounting bolts in reverse order as shown in the figure.

- A : Bank 1
- B : Bank 2
- C : Dowel pin hole

CAUTION:

Shaft is internally jointed with camshaft sprocket (INT) center hole. When removing, keep it horizontal until it is completely disconnected.

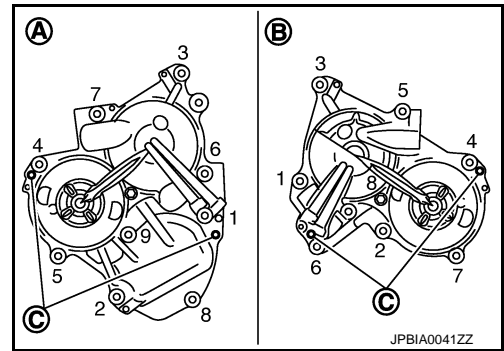

c. Shaft is engaged with intake side camshaft sprocket center hole on inside. pull straight out so as not to tilt until the joint is disengaged.

- The mating surface of magnet retarder (2) may be fitted with the exhaust side camshaft sprocket via the engine oil. Open valve timing control cover (1) carefully
- If the mating surface of magnet retarder is fitted with the camshaft sprocket, open the cover within the range that the load is not applied to the harness. And then, remove it so as to prevent magnet retarder from dropping.

CAUTION:

- Be careful not to damage magnet retarder.
- When carrying valve timing control cover, face the magnet retarder side up to prevent the cover from falling from magnet retarder.
- Never remove magnet retarder from valve timing control cover. (Disassembly prohibited parts)

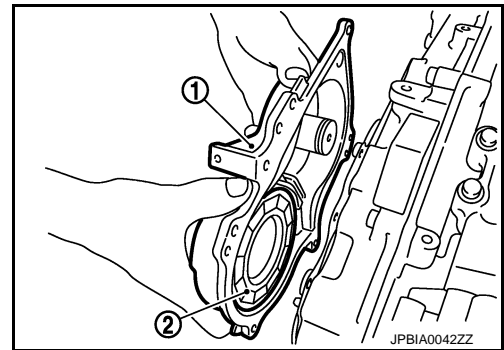

23. Remove rocker covers (bank 1 and bank 2). Refer to [EM-50, "Exploded View"](#).

24. Obtain No. 1 cylinder at TDC of its compression stroke as per the following:

a. Rotate crankshaft pulley clockwise to align timing mark (grooved line without color) with timing indicator.

← : Timing mark (grooved line without color)

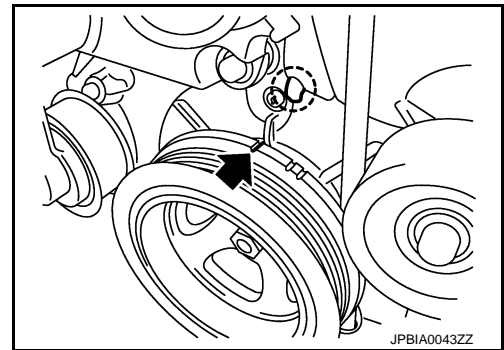

b. Check that intake and exhaust cam noses on No. 1 cylinder (engine front side of bank 1) are located as shown in the figure.

⇐ : Engine front

- If not, turn crankshaft one revolution (360 degrees) and align as shown in the figure.

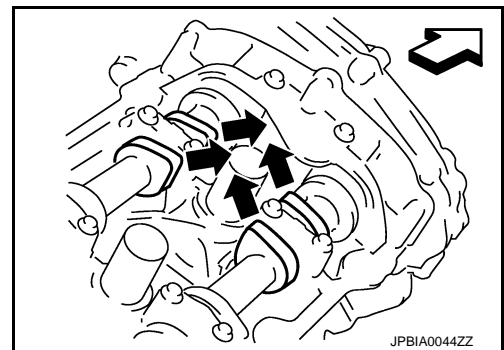

25. Remove crankshaft pulley as per the following:

- a. Remove front cross bar. Refer to [FSU-15, "Exploded View"](#) (2WD models) or [FSU-34, "Exploded View"](#) (AWD models)
- b. Remove power steering pipe mounting bolt. Refer to [ST-47, "VQ35HR : Exploded View"](#).

TIMING CHAIN

[VQ35HR]

< REMOVAL AND INSTALLATION >

- c. Remove rear cover plate and set the ring gear stopper [SST: KV10118600 (J-48641)] (A) as shown in the figure.

- 1 : Oil pan (upper)
- 2 : Drive plate
- ⇐ : Vehicle front

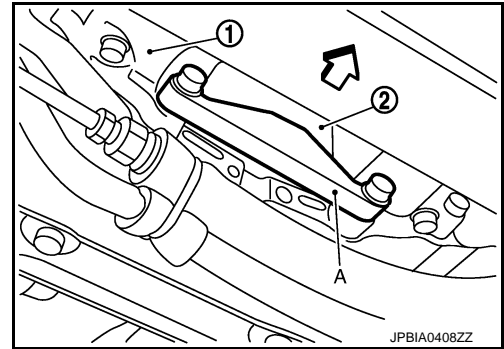

- d. Loosen crankshaft pulley bolt and rotate bolt seating surface at 10 mm (0.39 in) from its original position.

- 1 : Crankshaft pulley

CAUTION:

Never remove crankshaft pulley bolt as it will be used as a supporting point for suitable puller.

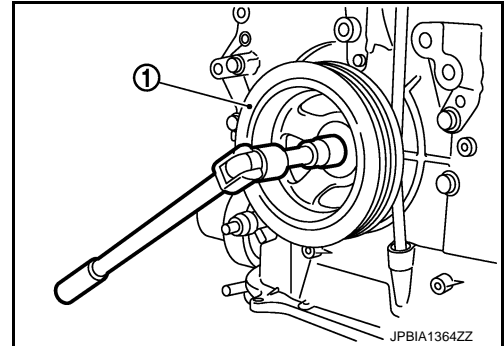

- e. Place suitable puller tab on holes of crankshaft pulley, and pull crankshaft pulley through.

CAUTION:

Never put suitable puller tab on crankshaft pulley periphery, as this will damage internal damper.

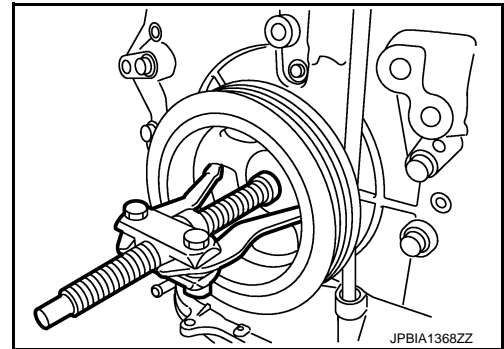

26. Remove oil pan (lower). Refer to [EM-46. "Exploded View"](#).

27. Loosen two mounting bolts in front of oil pan (upper) with power tool in reverse order as shown in the figure.

- ⇐ : Engine front

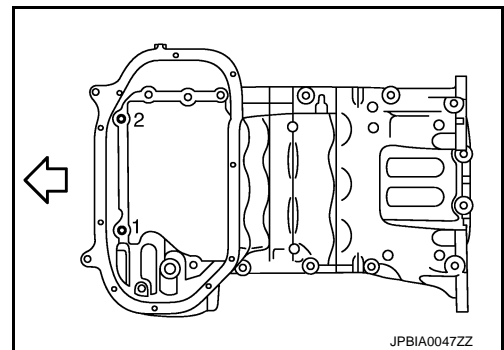

28. Remove front timing chain case as per the following:

TIMING CHAIN

[VQ35HR]

< REMOVAL AND INSTALLATION >

- a. Loosen mounting bolts in reverse order as shown in the figure.

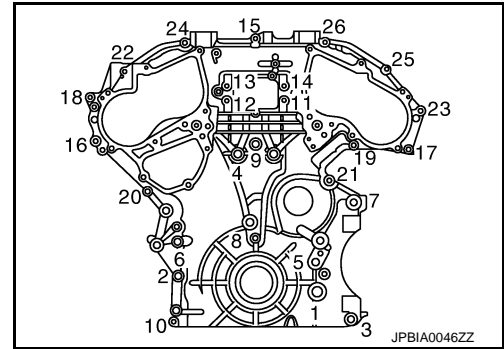

- b. Insert a suitable tool (A) into the notch at the top of front timing chain case as shown.
 c. Pry off case by moving the suitable tool as shown.
- Use the seal cutter [SST: KV10111100 (J-37228)] to cut liquid gasket for removal.

CAUTION:

- **Never use a screwdriver or something similar.**
- **After removal, handle front timing chain case carefully so it does not tilt, cant, or warp under a load.**

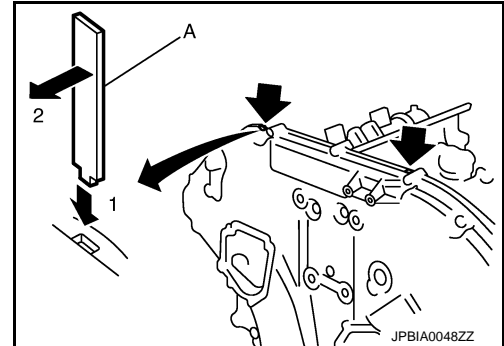

29. Remove front oil seal from front timing chain case using a suitable tool.

- Use a screwdriver for removal.

CAUTION:

Be careful not to damage front timing chain case.

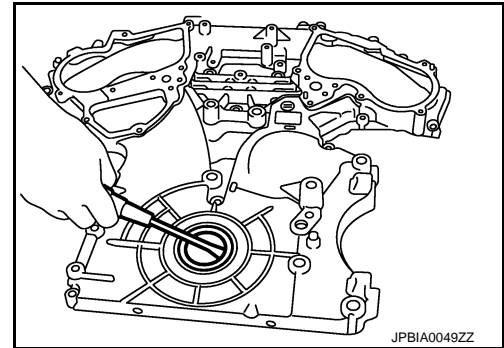

30. Remove O-rings (1) from rear timing chain case.

- A : Bank 1
- B : Bank 2

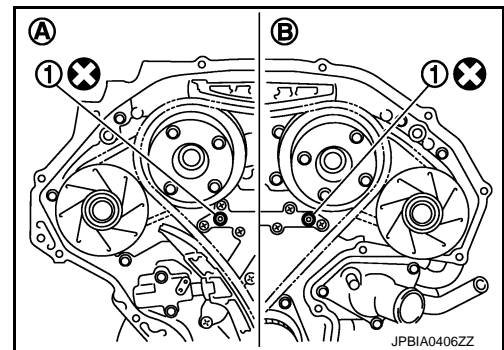

31. Remove timing chain tensioner (primary) as per the following:

A
EM
C
D
E
F
G
H
I
J
K
L
M
N
O
P

TIMING CHAIN

[VQ35HR]

< REMOVAL AND INSTALLATION >

- a. Remove lower mounting bolt (A).
- b. Loosen upper mounting bolt (B) slowly, and then turn timing chain tensioner (primary) (1) on the upper mounting bolt so that plunger (C) is fully expanded.

NOTE:

Even if plunger is fully expanded, it is not dropped from the body of timing chain tensioner (primary).

- c. Remove upper mounting bolt, and then remove timing chain tensioner (primary).

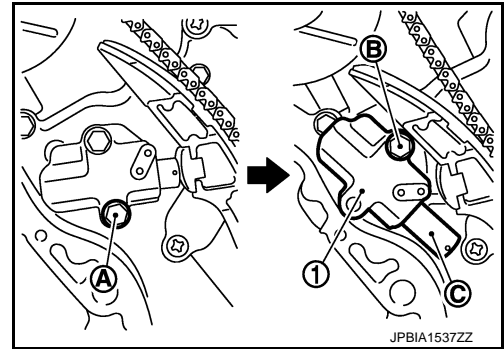

32. Remove internal chain guide (1), and slack guide (2).

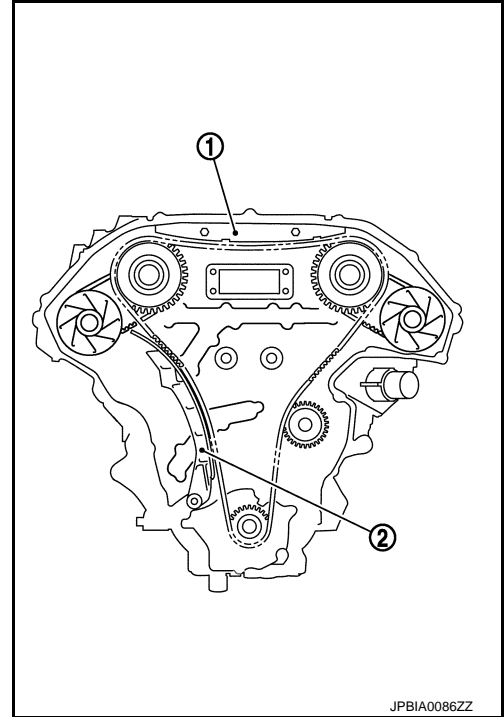

33. Remove timing chain (primary) and crankshaft sprocket.

CAUTION:

After removing timing chain tensioner (primary), never turn crankshaft and camshaft separately, or valves will strike the piston heads.

34. Remove timing chain (secondary) and camshaft sprockets as per the following:

- a. Attach suitable stopper pin (2) to the timing chain tensioners (secondary) (1).

A : Bank 1

B : Bank 2

NOTE:

- Use approximately 0.5 mm (0.02 in) dia. hard metal pin as a stopper pin.
- For removal of timing chain tensioners (secondary), refer to [EM-70. "Exploded View"](#). [Removing camshaft bracket (No. 1) is required.]

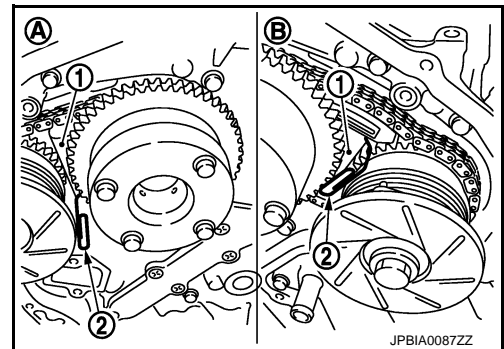

- b. Remove camshaft sprocket mounting bolts (INT and EXH).

TIMING CHAIN

[VQ35HR]

< REMOVAL AND INSTALLATION >

- Secure the hexagonal portion of camshaft using a wrench to loosen mounting bolts.
- c. Remove timing chain (secondary) together with camshaft sprockets.

CAUTION:

- **Never loosen the mounting bolts with securing anything other than the camshaft hexagonal portion or with tensioning the timing chain.**

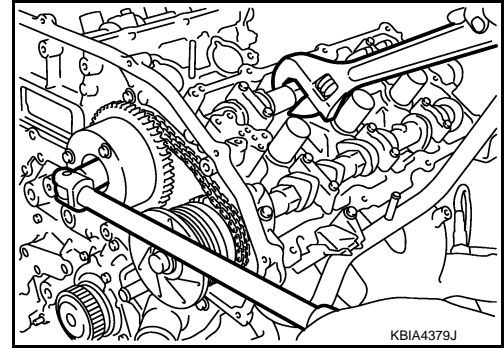

- **Never disassemble. [Never loosen bolts (A) and (B) as shown in the figure.]**

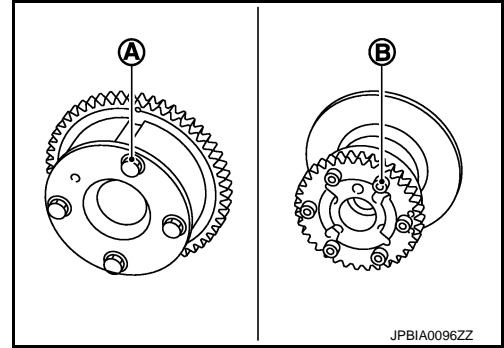

35. Remove timing chain tensioners (secondary) from cylinder head as per the following, if necessary.
- Remove camshaft brackets (No. 1). Refer to [EM-70. "Exploded View"](#).
 - Remove timing chain tensioners (secondary) with a stopper pin attached.

36. Use a scraper to remove all traces of old liquid gasket from front and rear timing chain cases and oil pan (upper), and liquid gasket mating surfaces.

CAUTION:

Be careful not to allow gasket fragments to enter oil pan.

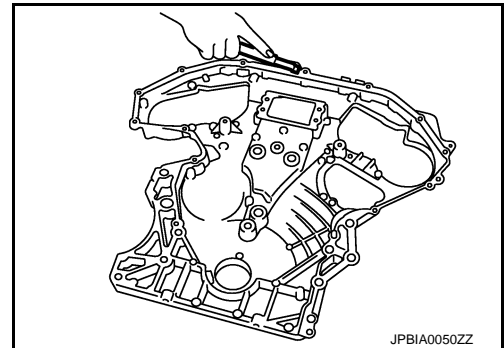

37. Remove old liquid gasket from bolt hole and thread.

A : Remove sticking old liquid gasket

B : Bolt hole

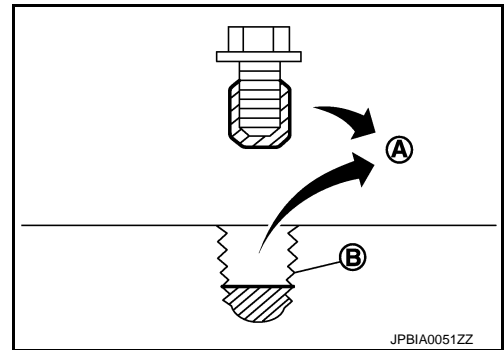

INSTALLATION

NOTE:

The below figure shows the relationship between the matching mark on each timing chain and that on the corresponding sprocket, with the components installed.

TIMING CHAIN

< REMOVAL AND INSTALLATION >

[VQ35HR]

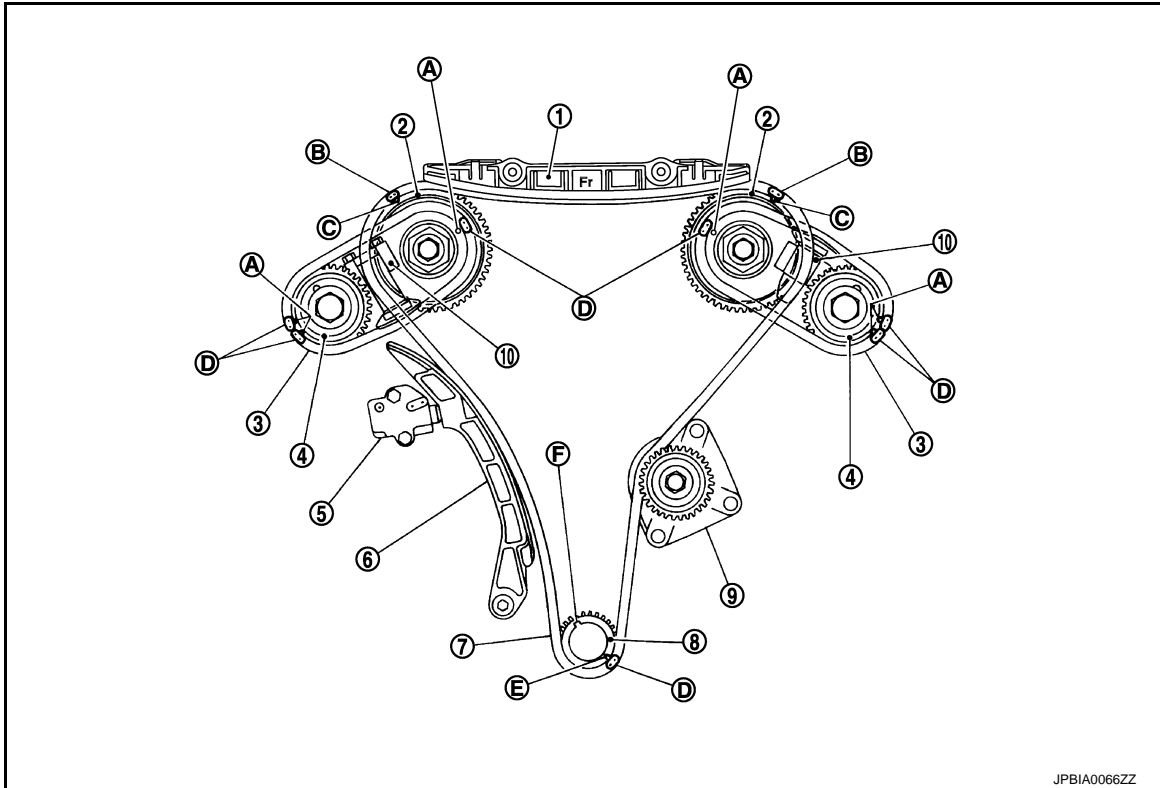

- | | | |
|--|-------------------------------------|-----------------------------|
| 1. Internal chain guide | 2. Camshaft sprocket (INT) | 3. Timing chain (secondary) |
| 4. Camshaft sprocket (EXH) | 5. Timing chain tensioner (primary) | 6. Slack guide |
| 7. Timing chain (primary) | 8. Crankshaft sprocket | 9. Water pump |
| 10. Timing chain tensioner (secondary) | | |
| A. Matching mark [punched (back side)] | B. Matching mark (yellow link) | C. Matching mark (punched) |
| D. Matching mark (orange link) | E. Matching mark (notched) | F. Crankshaft key |

1. Install timing chain tensioners (secondary) to cylinder head as follows if removed. Refer to [EM-70, "Exploded View"](#).
2. Check that dowel pin (A) and crankshaft key (1) are located as shown in the figure. (No. 1 cylinder at compression TDC)

NOTE:

Though camshaft does not stop at the position as shown in the figure, for the placement of cam noses, it is generally accepted camshaft is placed for the same direction of the figure.

Camshaft dowel pin

: At cylinder head upper face side in each bank.

Crankshaft key

: At cylinder head side of bank 1.

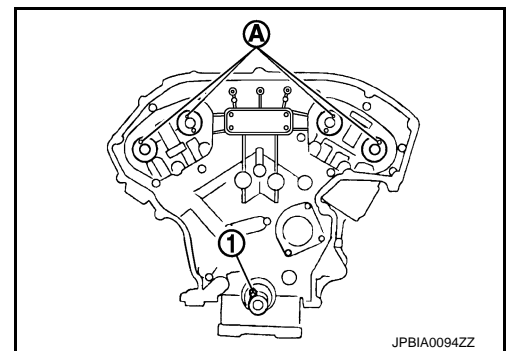

3. Install timing chains (secondary) and camshaft sprockets as per the following:
CAUTION:
Matching marks between timing chain and sprockets slip easily. Confirm all matching mark positions repeatedly during the installation process.

TIMING CHAIN

[VQ35HR]

< REMOVAL AND INSTALLATION >

- a. Push plunger of timing chain tensioner (secondary) and keep it pressed in with a stopper pin (A).

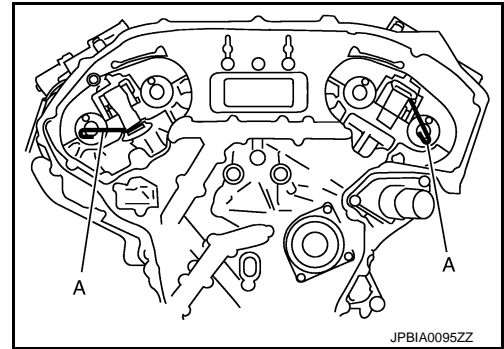

- b. Install timing chains (secondary) and camshaft sprockets.
- Align the matching marks on timing chain (secondary) (orange link) with the ones on intake and exhaust camshaft sprockets (punched), and install them.

- A : Camshaft sprocket (INT) back face
- B : Orange link
- C : Matching mark (Circle)
- D : Matching mark (Oval)
- E : Dowel groove
- F : Matching mark (2 oval)
- G : Camshaft sprocket (EXH) back face
- H : Matching mark (2 circle)
- I : Dowel hole
- J : Timing chain (secondary)

NOTE:

- Figure shows bank 1 (rear view).
- Matching marks for camshaft sprockets are on the back side of camshaft sprockets (secondary).
- There are two types of matching marks, circle and oval types. They should be used for the bank 1 and bank 2, respectively.

Bank 1 : Use circle type.

Bank 2 : Use oval type.

- Align dowel pin camshafts with the groove or dowel hole on sprockets, and install them.
- On the intake side, align dowel pin on camshaft front end with pin groove on the back side of camshaft sprocket, and install them.
- On the exhaust side, align dowel pin on camshaft front end with pin hole on camshaft sprocket, and install them.
- In case that positions of each matching mark and each dowel pin are not fit on matching parts, make fine adjustment to the position holding the hexagonal portion on camshaft with wrench or an equivalent.
- Mounting bolts for camshaft sprockets must be tightened in the next step. Tightening them by hand is enough to prevent the dislocation of dowel pins.
- Check the matching marks (punched) (D) on each camshaft sprocket are positioned on the matching marks (orange link) (C) on timing chain (secondary).

- A : Intake side
- B : Exhaust side

NOTE:

Matching mark (punched) in the figure is for checking loose at this step.

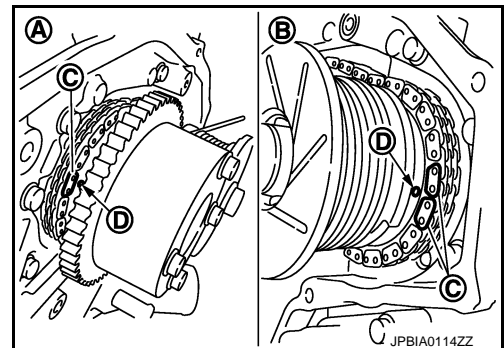
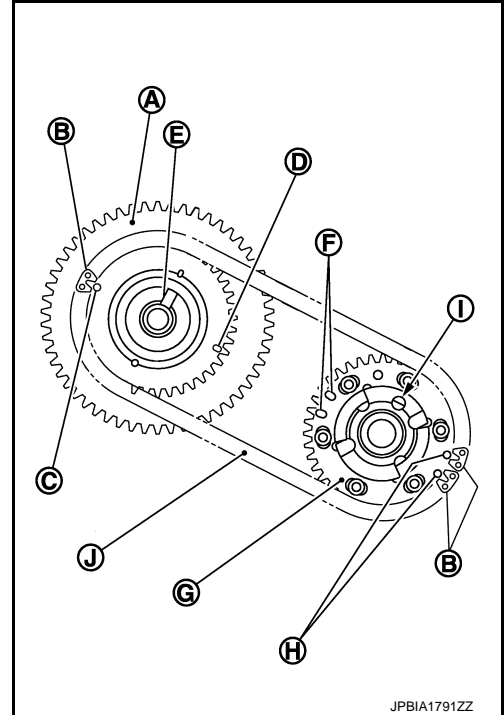

A

EM

C

D

E

F

G

H

I

J

K

L

M

N

O

P

TIMING CHAIN

< REMOVAL AND INSTALLATION >

[VQ35HR]

- c. After confirming the matching marks are aligned, tighten camshaft sprocket mounting bolts.
- Secure camshaft using a wrench at the hexagonal portion to tighten mounting bolts.

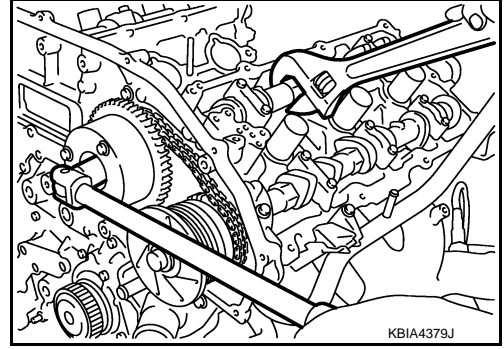

- d. Pull stopper pins (2) out from timing chain tensioners (secondary) (1).

- A : Bank 1
B : Bank 2

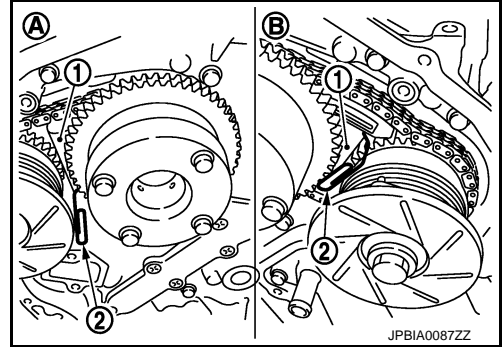

4. Install timing chain (primary) as per the following:

- a. Install crankshaft sprocket (1).

- A : Matching mark (Front side)
⇐ : Engine front

- Check the matching marks on crankshaft sprocket face the front of the engine.

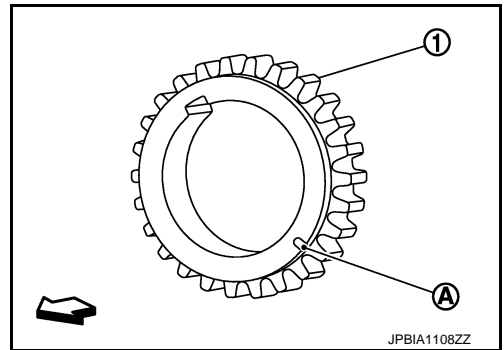

- b. Install timing chain (primary).

TIMING CHAIN

[VQ35HR]

< REMOVAL AND INSTALLATION >

- Install timing chain (primary) so the matching mark (punched) (B) on camshaft sprocket (INT) (1) is aligned with the yellow link (A) on timing chain, while the matching mark (notched) (C) on crankshaft sprocket (2) is aligned with the orange link (D) on timing chain, as shown in the figure.

3 : Water pump

- When it is difficult to align matching marks of timing chain (primary) with each sprocket, gradually turn camshaft using wrench on the hexagonal portion to align it with the matching marks.
- During alignment, be careful to prevent dislocation of matching mark alignments of timing chains (secondary).

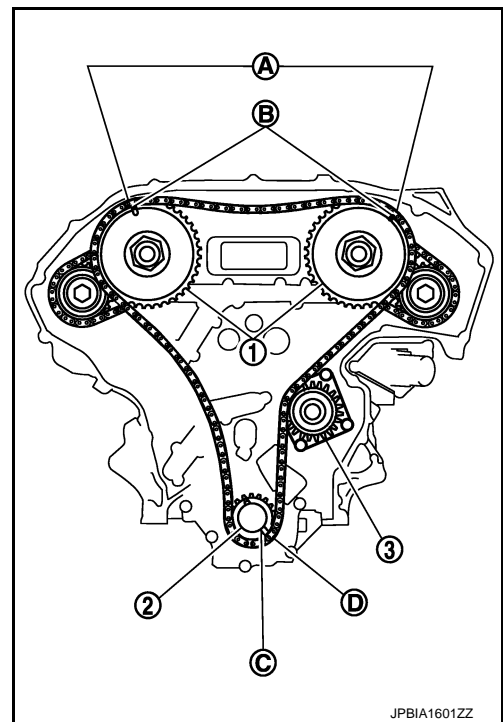

5. Install internal chain guide (1), slack guide (2).

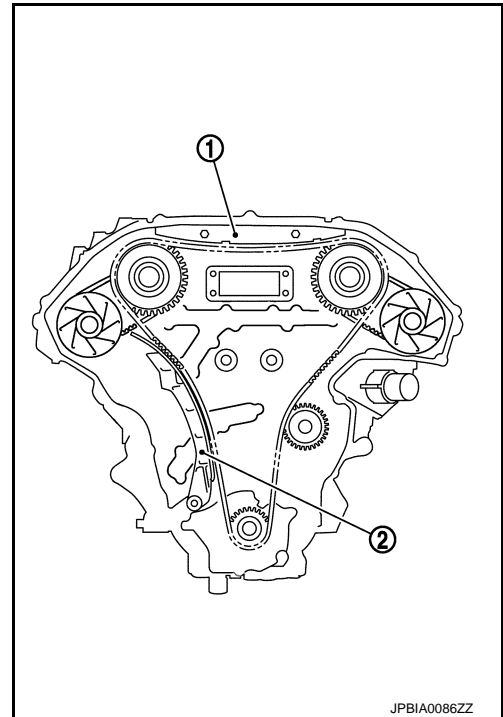

CAUTION:

A
EM
C
D
E
F
G
H
I
J
K
L
M
N
O
P

TIMING CHAIN

< REMOVAL AND INSTALLATION >

[VQ35HR]

Never overtighten slack guide mounting bolts (2). It is normal for a gap (A) to exist under the bolt seats when mounting bolts are tightened to the specification.

- 1 : Slack guide
- 2 : Bolt
- 3 : Cylinder block

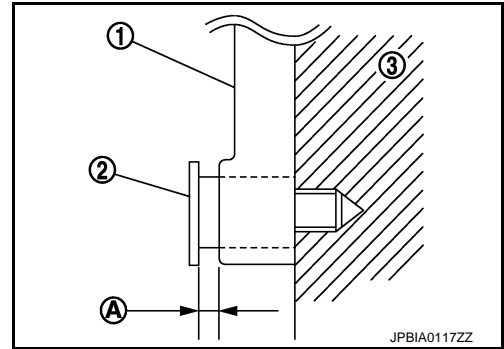

6. Install the timing chain tensioner (primary) with the following procedure:

- a. Pull plunger stopper tab (A) up (or turn lever downward) so as to remove plunger stopper tab from the ratchet of plunger (D).

NOTE:

Plunger stopper tab and lever (C) are synchronized.

- b. Push plunger into the inside of tensioner body.
 c. Hold plunger in the fully compressed position by engaging plunger stopper tab with the tip of ratchet.
 d. To secure lever, insert stopper pin (E) through hole of lever into tensioner body hole (B).
 • The lever parts and the plunger stopper tab are synchronized. Therefore, the plunger will be secured under this condition.

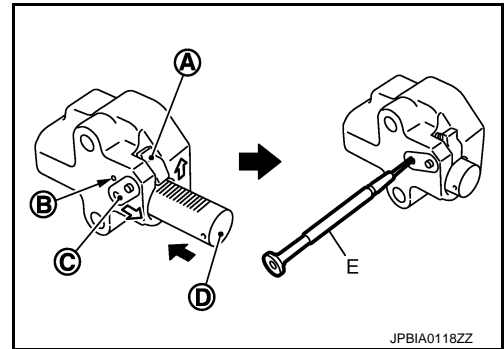

NOTE:

Figure shows the example of 1.2 mm (0.047 in) diameter thin screwdriver being used as the stopper pin.

- e. Install timing chain tensioner (primary) (1).
 • Remove any dirt and foreign materials completely from the back and the mounting surfaces of timing chain tensioner (primary).
 f. Pull out stopper pin (A) after installing, and then release plunger.

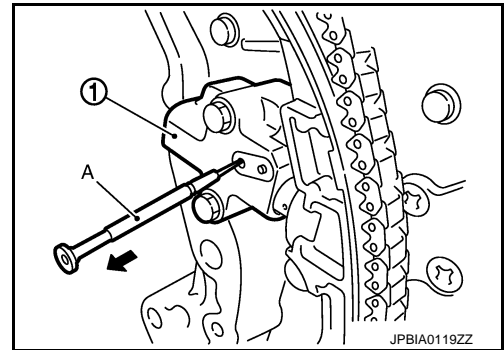

7. Check again that the matching marks on sprockets and timing chain have not slipped out of alignment.

8. Install new O-rings (1) on rear timing chain case.

- A : Bank 1
- B : Bank 2

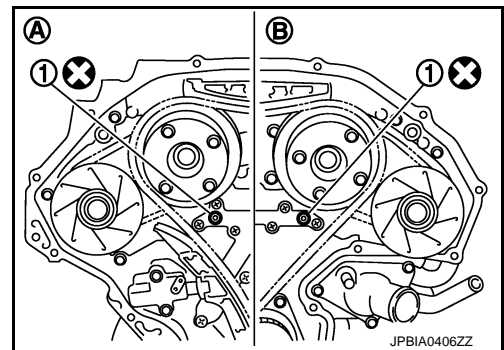

9. Install new front oil seal on front timing chain case.

TIMING CHAIN

[VQ35HR]

< REMOVAL AND INSTALLATION >

- Apply new engine oil to both oil seal lip (A) and dust seal lip (B).
- ↔ : Engine inside
 - ← : Engine outside
- Install it so that each seal lip is oriented as shown in the figure.

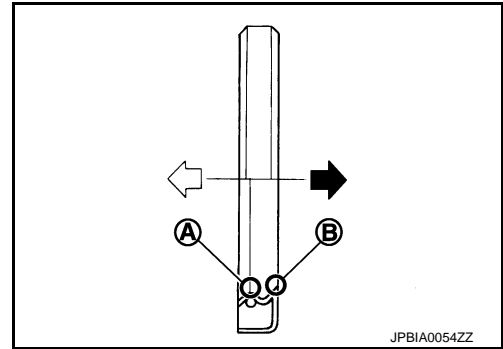

- Using a suitable drift [outer diameter: 60 mm (2.36 in)] (A), press-fit oil seal until it becomes flush with front timing chain case end face.
- Check the garter spring is in position and seal lip is not inverted.

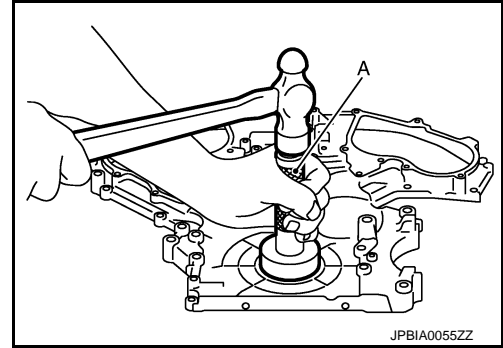

- Install front timing chain case as per the following:
 - Check O-rings stay in place during installation to rear timing chain case.
- Apply a continuous bead of liquid gasket with the tube presser (commercial service tool) to front timing chain case back side as shown in the figure.

- B : Protrusion
- c : $\phi 3.4 - 4.4$ mm (0.134 - 0.173 in)
- d : $\phi 2.6 - 3.6$ mm (0.102 - 0.142 in)
- e : 4.0 - 5.6 mm (0.157 - 0.220 in)

Use Genuine RTV Silicone Sealant or an equivalent. Refer to [GI-15, "Recommended Chemical Products and Sealants"](#).

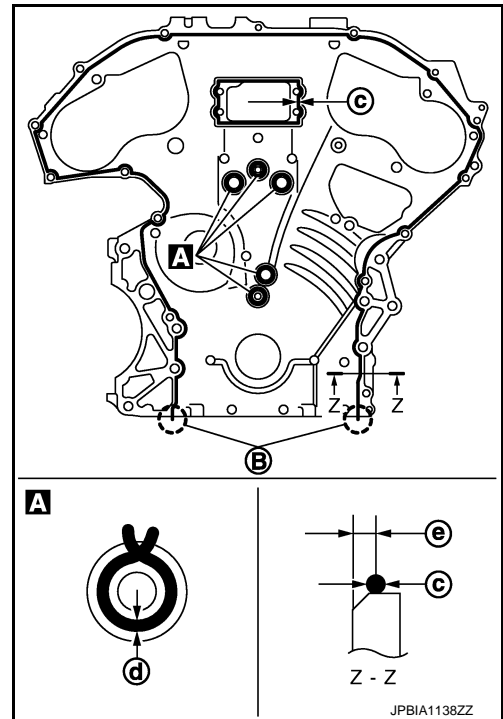

A
EM
C
D
E
F
G
H
I
J
K
L
M
N
O
P

TIMING CHAIN

[VQ35HR]

< REMOVAL AND INSTALLATION >

- b. Apply liquid gasket to top surface of oil pan (upper) as shown in the figure.

A : $\phi 4.0 - 5.0$ mm (0.157 - 0.197 in)

Use Genuine RTV silicone Sealant or an equivalent. Refer to [GI-15, "Recommended Chemical Products and Sealants"](#).

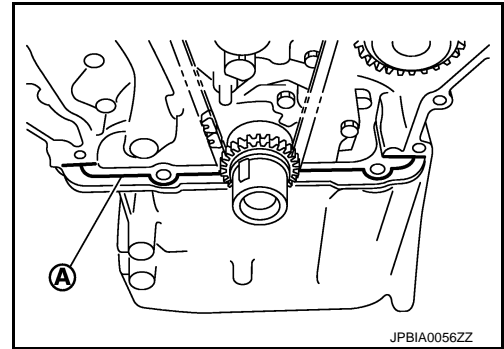

- c. Assemble front timing chain case.

- 1 : Front timing chain case
- 2 : Oil pan (upper)
- 3 : Cylinder block
- ⇐ : Engine front

CAUTION:

- Be careful not to damage front oil seal by interference with front end of crankshaft.
- Attaching must be done within 5 minutes after liquid gasket application.

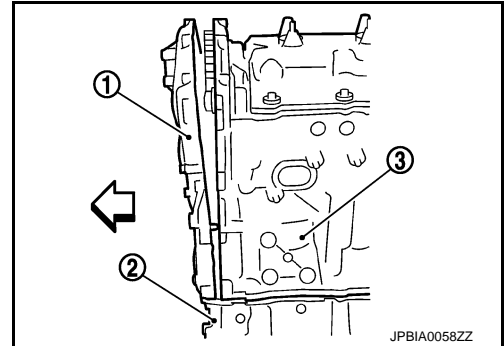

- d. Install front timing chain case as to fit its dowel pin hole together with dowel pin on rear timing chain case.

- e. Tighten mounting bolts to the specified torque in numerical order as shown in the figure.

- There are two types of mounting bolts. Refer to the following for locating bolts.

M10 bolts : 1, 2, 3, 4, 5, 6, 7

: 55.0 N·m (5.6 kg-m, 41 ft-lb)

M6 bolts : Except the above

: 12.7 N·m (1.3 kg-m, 9 ft-lb)

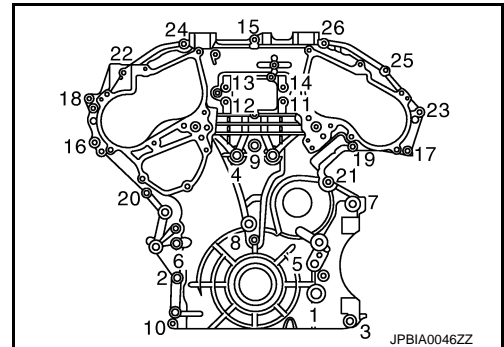

- f. After all bolts are tightened, retighten them to the specified torque in numerical order shown in the figure.

CAUTION:

Be sure to wipe out any excessive liquid gasket leaking on surface mating with oil pan (upper).

- g. Install two mounting bolts in front of oil pan (upper) in numerical order shown in the figure.

⇐ : Engine front

Tightening torque : Refer to [EM-46, "Exploded View"](#).

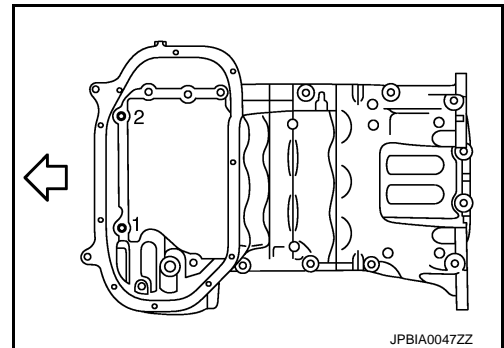

11. Install valve timing control covers (bank 1 and bank 2) as per the following:

TIMING CHAIN

[VQ35HR]

< REMOVAL AND INSTALLATION >

- a. Install new seal rings (1) in shaft grooves.

A : Bank 2

CAUTION:

When replacing seal ring, replace all rings with new one.

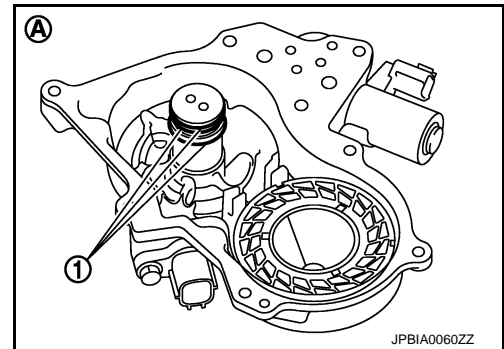

- b. To check the joint between dowel pins and dowel pin holes, check the looseness in the axle direction by pushing the circumferential looseness (between dowel pins and dowel pin holes) by twisting in the circumferential direction.

A : Mating surface of magnet retarder

B : Moves slightly

C : Not shaken

CAUTION:

Always perform this procedure when removing because the gap between dowel pins and dowel pin holes may not be caused on purpose.

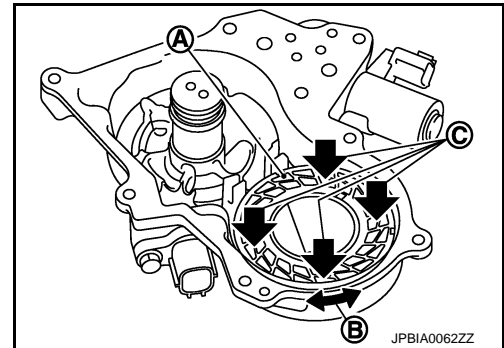

- c. Install valve timing control cover with new gasket to front timing chain case.

1 : Valve timing control cover

2 : Magnet retarder

CAUTION:

- Never face the magnet retarder side down to prevent magnet retarder from dropping.
- Check the mating surface of magnet retarder and the drum of exhaust side camshaft sprocket for foreign materials.
- Align the center of both shaft holes of the shaft and the intake side camshaft sprocket, and then insert them.
- Be careful not to drop the seal ring from the shaft groove.
- When setting the valve timing control cover in position by hand, if valve timing control cover is not contacting with the front timing chain case, the dowel pin of magnet retarder may not be aligned with the dowel pin holes of cover. In this case, return to step "b".

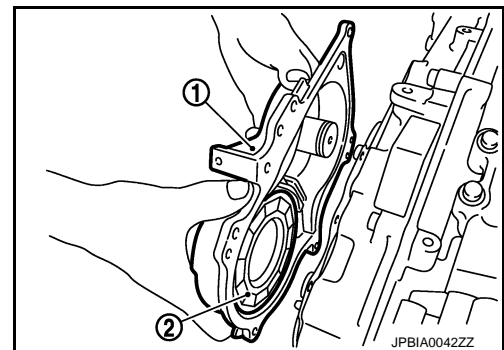

- d. Being careful not to move seal ring from the installation groove, align dowel pins on front timing chain case with holes to install valve timing control covers.

- e. Tighten mounting bolts in numerical order as shown in the figure.

A : Bank 1

B : Bank 2

C : Dowel pin hole

Tightening torque : Refer to [EM-53, "Exploded View"](#).

- After all bolts are tightened, tighten No. 1 bolt to the specified torque again.

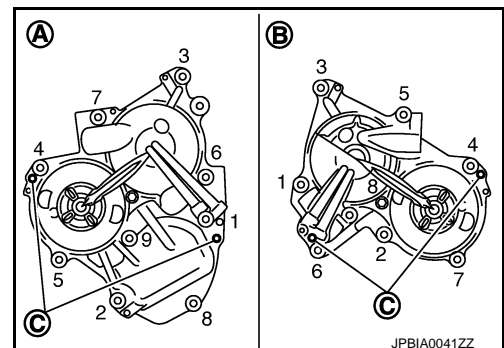

12. Install oil pan (lower). Refer to [EM-46, "Exploded View"](#).

TIMING CHAIN

[VQ35HR]

< REMOVAL AND INSTALLATION >

13. Install rocker covers (bank 1 and bank 2). Refer to [EM-50. "Exploded View"](#).
14. Install crankshaft pulley as per the following:
 - a. Fix crankshaft using the ring gear stopper [SST: KV10118600 (J-48641)].
 - b. Install crankshaft pulley, taking care not to damage front oil seal.
 - When press-fitting crankshaft pulley with plastic hammer, tap on its center portion (not circumference).
 - c. Tighten crankshaft pulley bolt.

 **44.1 N·m (4.5 kg·m, 33 ft·lb)**

- d. Place a matching mark (A) on crankshaft pulley (2) aligning with the matching mark (C) of crankshaft pulley bolt (1). Tighten the bolt 90 degrees (one marks) (b).

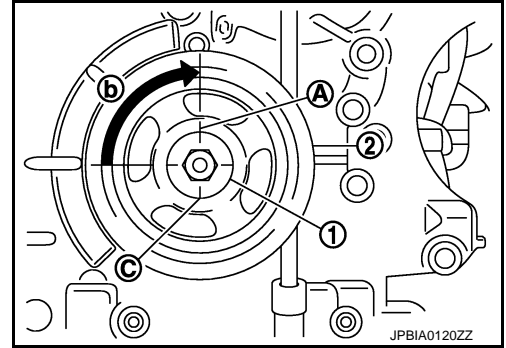

- e. Rotate crankshaft pulley in normal direction (clockwise when viewed from front) to confirm it turns smoothly.
15. Install drive belt auto-tensioner bracket (1) and power steering oil pump bracket (2) as per the following:

- 3 : Crankshaft pulley
- A : Engine front side
- B : Engine right side
-  : Engine front

- a. Install drive belt auto-tensioner bracket, and tighten mounting bolts No. 2, 3. (temporarily)
- b. Tighten mounting bolts No. 2, 3. (specified torque)
- c. Install power steering oil pump bracket, and tighten mounting bolts No. 1, 4, 5. (temporarily)
- d. Tighten mounting bolts No. 1. (specified torque)
- e. Tighten mounting bolts No. 4, 5. (specified torque)

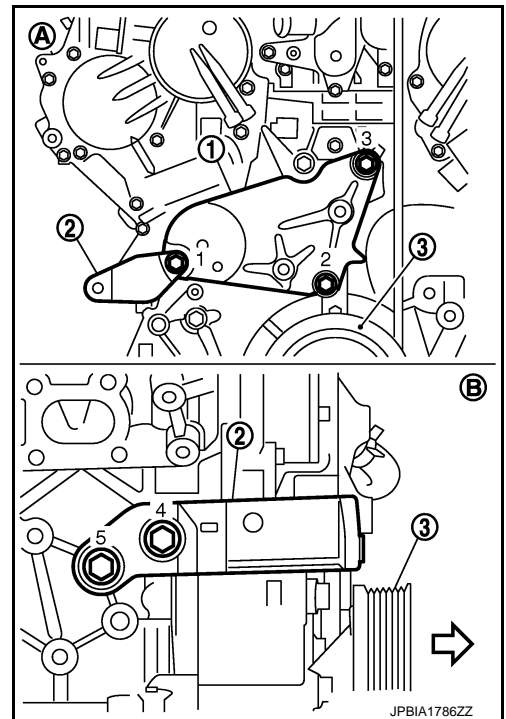

16. For the following operations, perform steps in the reverse order of removal.

Inspection

INFOID:000000003887361

INSPECTION AFTER REMOVAL

Timing Chain

TIMING CHAIN

[VQ35HR]

< REMOVAL AND INSTALLATION >

Check for cracks and any excessive wear at link plates and roller links of timing chain. Replace timing chain if necessary.

- A : Crack
- B : Wear

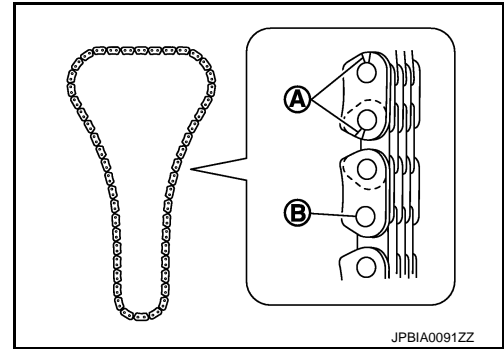

JPBIA0091ZZ

INSPECTION AFTER INSTALLATION

Inspection for Leakage

The following are procedures for checking fluids leakage, lubricates leakage.

- Before starting engine, check oil/fluid levels including engine coolant and engine oil. If less than required quantity, fill to the specified level. Refer to [MA-12, "Fluids and Lubricants"](#).
- Use procedure below to check for fuel leakage.
 - Turn ignition switch "ON" (with engine stopped). With fuel pressure applied to fuel piping, check for fuel leakage at connection points.
 - Start engine. With engine speed increased, check again for fuel leakage at connection points.
- Run engine to check for unusual noise and vibration.

NOTE:

If hydraulic pressure inside chain tensioner drops after removal/installation, slack in guide may generate a pounding noise during and just after the engine start. However, this does not indicate an unusualness. Noise will stop after hydraulic pressure rises.

- Warm up engine thoroughly to check there is no leakage of fuel, or any oil/fluids including engine oil and engine coolant.
- Bleed air from lines and hoses of applicable lines, such as in cooling system.
- After cooling down engine, again check oil/fluid levels including engine oil and engine coolant. Refill to the specified level, if necessary.

Summary of the inspection items:

Items	Before starting engine	Engine running	After engine stopped
Engine coolant	Level	Leakage	Level
Engine oil	Level	Leakage	Level
Other oils and fluid*	Level	Leakage	Level
Fuel	Leakage	Leakage	Leakage

* Transmission/transaxle/CVT fluid, power steering fluid, brake fluid, etc.

A
EM
C
D
E
F
G
H
I
J
K
L
M
N
O
P

CAMSHAFT

< REMOVAL AND INSTALLATION >

[VQ35HR]

CAMSHAFT

Exploded View

INFOID:000000003887362

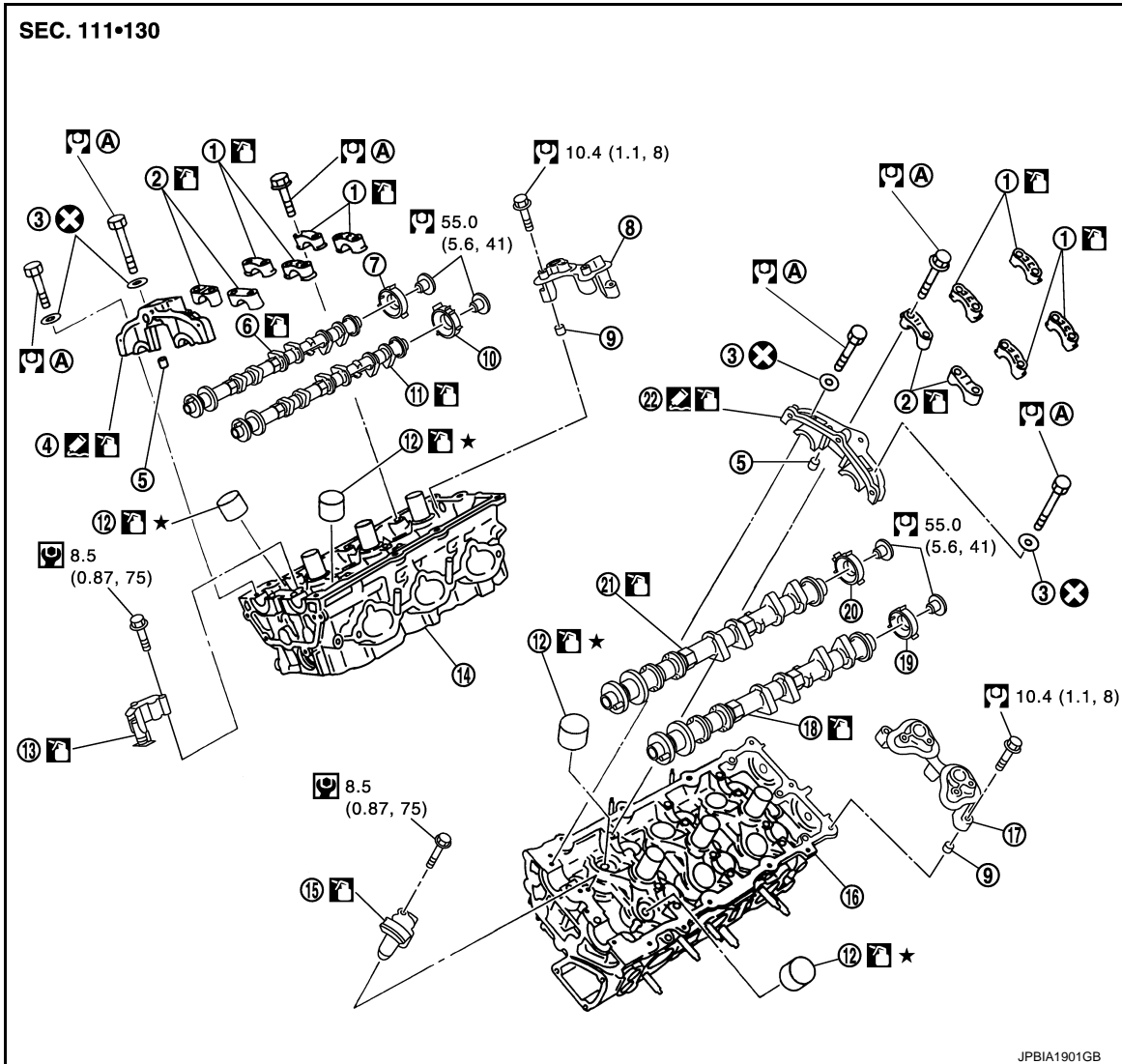

- | | | |
|---|--------------------------------------|---|
| 1. Camshaft bracket (No. 3, 4) | 2. Camshaft bracket (No. 2) | 3. Seal washer |
| 4. Camshaft bracket (No. 1) (bank 1) | 5. Dowel pin | 6. Camshaft (EXH) (bank 1) |
| 7. Camshaft signal plate (EXH) | 8. Camshaft sensor bracket (bank 1) | 9. Dowel pin |
| 10. Camshaft signal plate (INT) | 11. Camshaft (INT) (bank 1) | 12. Valve lifter |
| 13. Timing chain tensioner (secondary) (bank 1) | 14. Cylinder head (bank 1) | 15. Timing chain tensioner (secondary) (bank 2) |
| 16. Cylinder head (bank 2) | 17. Camshaft sensor bracket (bank 2) | 18. Camshaft (EXH) (bank 2) |
| 19. Camshaft signal plate (EXH) | 20. Camshaft signal plate (INT) | 21. Camshaft (INT) (bank 2) |
| 22. Camshaft bracket (No. 1) (bank 2) | | |
- A. Refer to [EM-70](#)

Refer to [GI-4, "Components"](#) for symbols in the figure.

Removal and Installation

INFOID:000000003887363

REMOVAL

1. Remove front timing chain case, camshaft sprocket and timing chain. Refer to [EM-53, "Exploded View"](#).
2. Remove fuel sub tube. Refer to [EM-40, "Exploded View"](#).

CAMSHAFT

[VQ35HR]

< REMOVAL AND INSTALLATION >

3. Remove camshaft sensor bracket.
 - Loosen camshaft sensor bracket bolts in reverse order as shown in the figure.

← : Engine front

NOTE:

The order of loosening bolts is the same for bank 1 and bank 2.

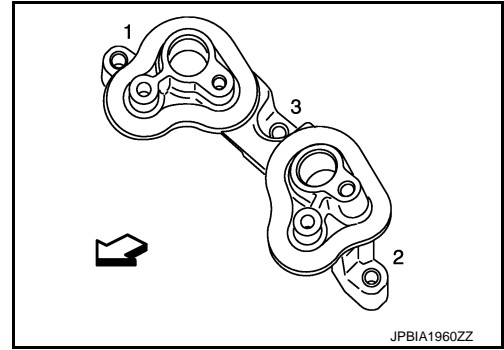

4. Remove camshaft brackets.
 - Mark camshafts, camshaft brackets and bolts so they are placed in the same position and direction for installation.
 - Equally loosen camshaft bracket bolts in several steps in reverse order as shown in the figure.

← : Engine front

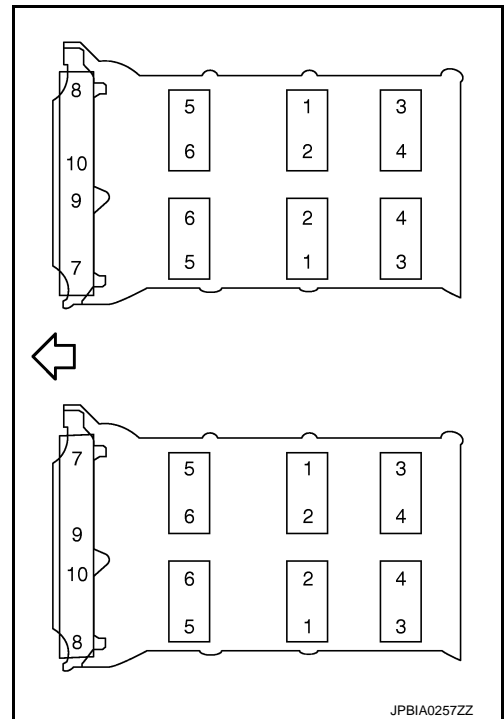

5. Remove camshaft.
6. Remove valve lifter.
 - Identify installation positions, and store them without mixing them up.
7. Remove timing chain tensioners (secondary) (1) from cylinder head.

A : Bank 1
B : Bank 2

- Remove timing chain tensioners (secondary) with its stopper pin (C) attached.

NOTE:

Stopper pin should be attached when timing chain (secondary) is removed.

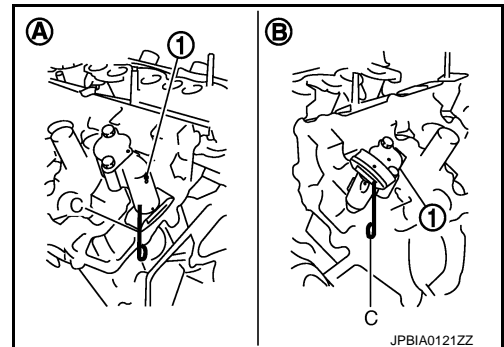

INSTALLATION

1. Install timing chain tensioners (secondary) on both sides of cylinder head.

A
EM
C
D
E
F
G
H
I
J
K
L
M
N
O
P

CAMSHAFT

[VQ35HR]

< REMOVAL AND INSTALLATION >

- Install timing chain tensioners (1) with its stopper pin (C) attached.

Bank 1 side (A) : Sliding part facing downward

Bank 2 side (B) : Sliding part facing upward

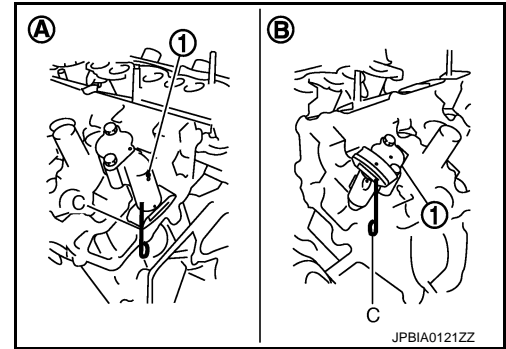

2. Install valve lifter.
 - Install it in the original position.
3. Install camshafts.
 - Follow your identification marks made during removal, or follow the identification marks that are present on new camshafts for proper placement and direction.

↔ : Engine front

Bank	INT/EXH	Dowel pin (1)	Paint marks			Identification mark (C)
			M1 (E)	M2 (F)	M3 (D)	
1	EXH (B)	Yes	No	Green	Light blue	1F
	INT (A)	Yes	Green	No	Light blue	1E
2	INT (A)	Yes	Green	No	Light blue	1G
	EXH (B)	Yes	No	Green	Light blue	1H

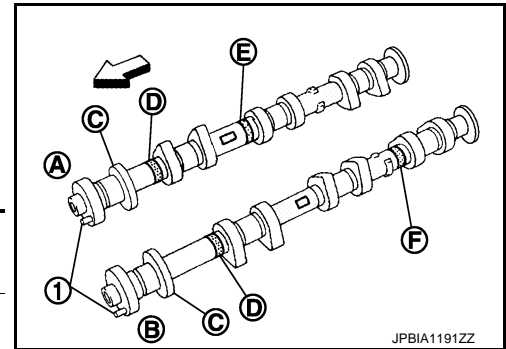

- Install camshaft so that dowel pin (A) on front end face are positioned as shown in the figure. (No. 1 cylinder TDC on its compression stroke)

1 : Crankshaft key

NOTE:

Though camshaft does not stop at the portion as shown in the figure, for the placement of cam nose, it is generally accepted camshaft is placed for the same direction of the figure.

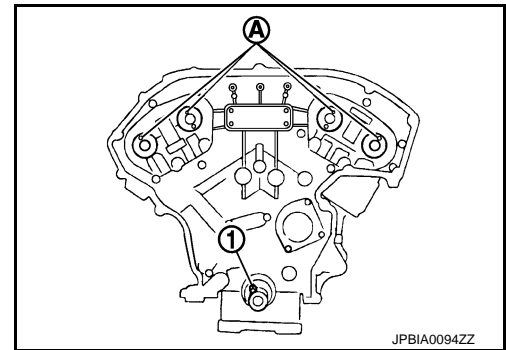

CAMSHAFT

< REMOVAL AND INSTALLATION >

[VQ35HR]

4. Install camshaft brackets.

- A : No. 1
- B : No. 2
- C : No. 3
- D : No. 4
- E : Camshaft brackets (bank 1)
- F : Exhaust side
- G : Intake side
- H : Camshaft brackets (bank 2)
- I : Intake side
- J : Exhaust side
- ⇐ : Engine front

- Remove foreign material completely from camshaft bracket backside and from cylinder head installation face.
- Install camshaft bracket in original position and direction as shown in figure.

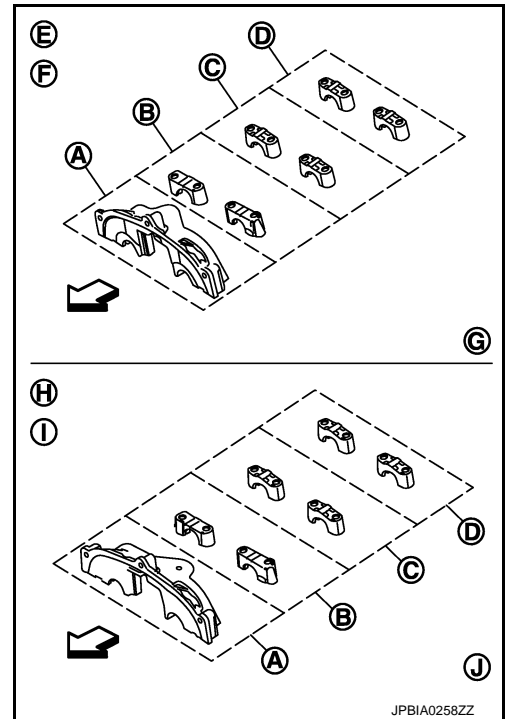

- Install camshaft brackets (No. 2 to 4) aligning the stamp marks (A) as shown in the figure.

- B : Bank 1
- C : Bank 2
- ⇐ : Engine front

NOTE:

There are no identification marks indicating bank 1 and bank 2 for camshaft bracket (No. 1).

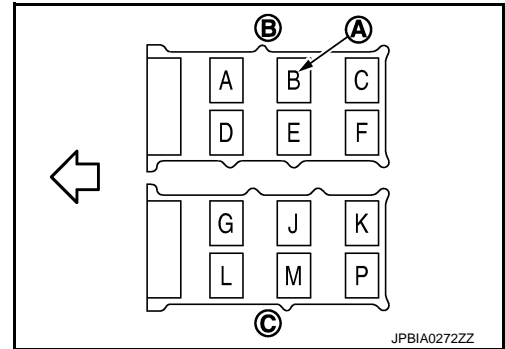

- Apply liquid gasket to mating surface of camshaft bracket (No. 1) as shown on both bank 1 and bank 2.

- a : 8.5 mm (0.335 in)
- b : 2 mm (0.08 in)
- c : Clearance 5 mm (0.20 in)
- d : $\phi 2.5$ mm (0.098 in)
- * : Apply liquid gasket to rear timing chain side

Use Genuine RTV Silicone Sealant or an equivalent. Refer to [GI-15, "Recommended Chemical Products and Sealants"](#).

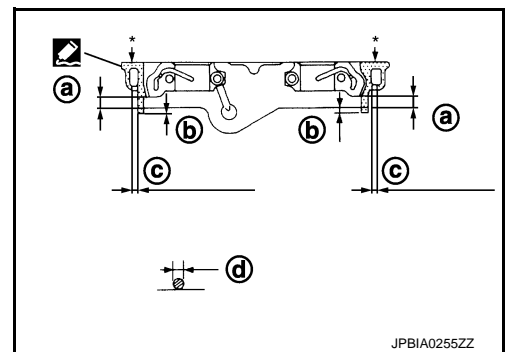

CAMSHAFT

[VQ35HR]

< REMOVAL AND INSTALLATION >

- Apply liquid gasket to camshaft bracket (No. 1) contact surface on the rear timing chain case backside as shown on both bank 1 and bank 2.

1 : Rear timing chain case

a : $\phi 3.9$ mm (0.154 in)

Use Genuine RTV Silicone Sealant or an equivalent. Refer to [GI-15, "Recommended Chemical Products and Sealants"](#).

CAUTION:

For camshaft bracket (No. 1) near installation position, and install it without disturbing the liquid gasket applied to the surfaces.

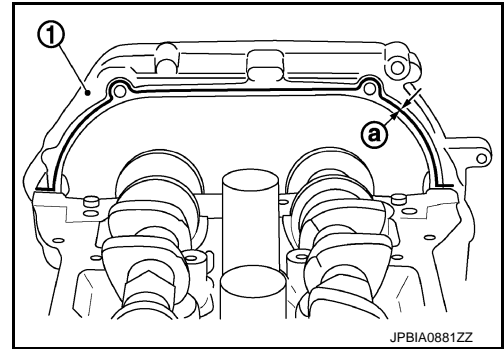

- Tighten camshaft bracket bolts in the following steps, in numerical order as shown in the figure.

← : Engine front

- Tighten No. 7 to 10 in numerical order as shown.

: 1.96 N·m (0.20 kg·m, 1 ft·lb)

- Tighten No. 1 to 6 in numerical order as shown.

: 1.96 N·m (0.20 kg·m, 1 ft·lb)

- Tighten No. 1 to 10 in numerical order as shown.

: 5.88 N·m (0.60 kg·m, 4 ft·lb)

- Tighten No. 1 to 10 in numerical order as shown.

: 10.4 N·m (1.1 kg·m, 8 ft·lb)

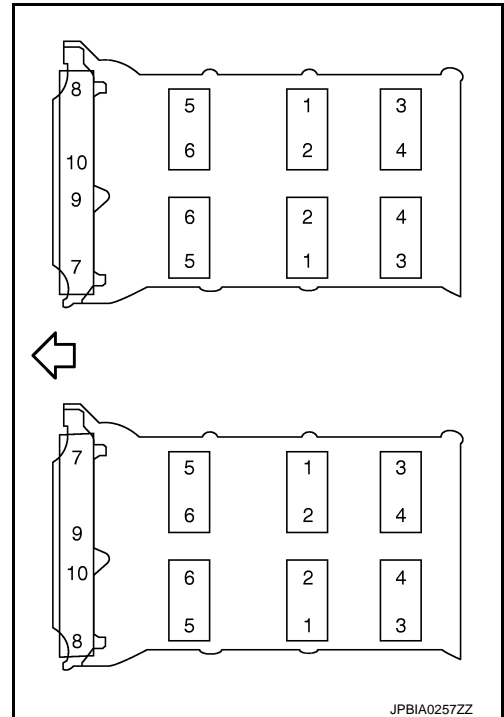

- Install camshaft sensor bracket.

- Tighten camshaft sensor bracket bolts in numerical order as shown in the figure.

← : Engine front

NOTE:

The order of tightening bolts is the same for bank 1 and bank 2.

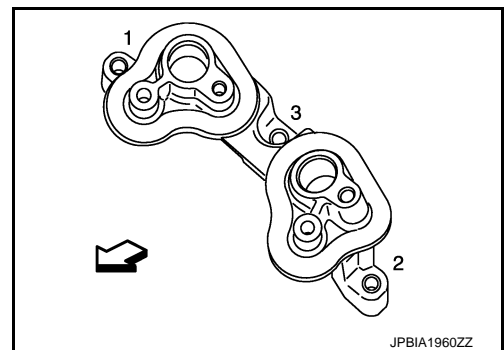

- Inspect and adjust the valve clearance. Refer to [EM-20, "Inspection and Adjustment"](#).

- Install in the reverse order of removal after this step.

Inspection

INFOID:000000003887364

INSPECTION AFTER REMOVAL

Camshaft Runout

CAMSHAFT

[VQ35HR]

< REMOVAL AND INSTALLATION >

1. Put V-block on precise flat table, and support No. 2 and 4 journals of camshaft.

CAUTION:

Never support No. 1 journal (on the side of camshaft sprocket) because it has a different diameter from the other three locations.

2. Set a dial indicator vertically to No. 3 journal.
3. Turn camshaft to one direction with hands, and measure the camshaft runout on a dial indicator. (Total indicator reading)

Standard and limit : Refer to [EM-143, "Camshaft"](#).

4. If it exceeds the limit, replace camshaft.

Camshaft Cam Height

1. Measure the camshaft cam height with a micrometer.

Standard cam height (Intake and exhaust) : Refer to [EM-143, "Camshaft"](#).

Cam wear limit : Refer to [EM-143, "Camshaft"](#).

2. If wear exceeds the limit, replace camshaft.

Camshaft Journal Oil Clearance

CAMSHAFT JOURNAL DIAMETER

- Measure the outer diameter of camshaft journal with a micrometer (A).

Standard : Refer to [EM-143, "Camshaft"](#).

CAMSHAFT BRACKET INNER DIAMETER

- Tighten camshaft bracket bolt with the specified torque. Refer to "INSTALLATION" for the tightening procedure.
- Measure inner diameter (A) of camshaft bracket with a bore gauge.

Standard : Refer to [EM-143, "Camshaft"](#).

CAMSHAFT JOURNAL OIL CLEARANCE

- (Oil clearance) = (Camshaft bracket inner diameter) – (Camshaft journal diameter).

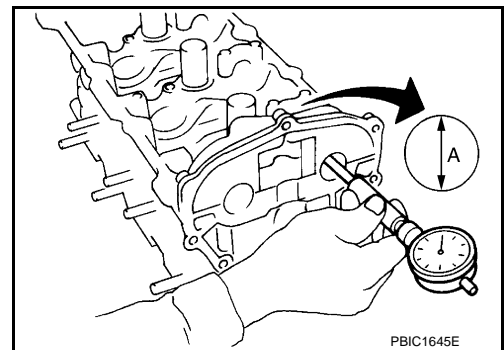
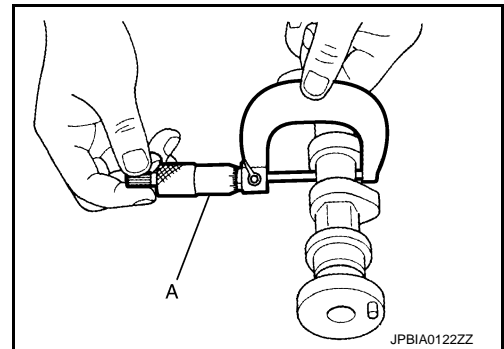
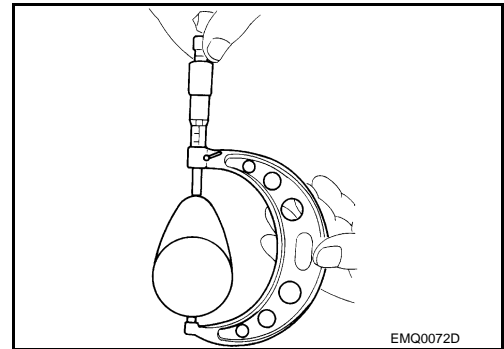
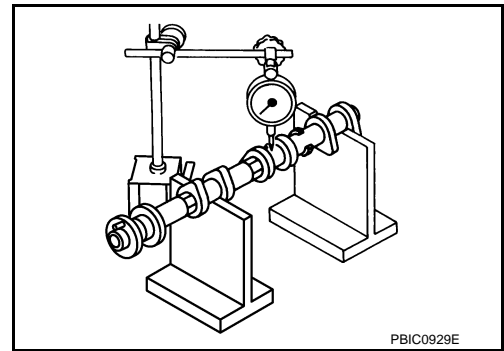

A
EM
C
D
E
F
G
H
I
J
K
L
M
N
O
P

CAMSHAFT

< REMOVAL AND INSTALLATION >

[VQ35HR]

Standard and limit : Refer to [EM-143, "Camshaft"](#).

- If the calculated value exceeds the limit, replace either or both camshaft and cylinder head.

NOTE:

Camshaft brackets cannot be replaced as single parts, because there are machined together with cylinder head. Replace whole cylinder head assembly.

Camshaft End Play

- Install a dial indicator in thrust direction on front end of camshaft. Measure the end play of a dial indicator when camshaft is moved forward/backward (in direction to axis).

Standard and limit : Refer to [EM-143, "Camshaft"](#).

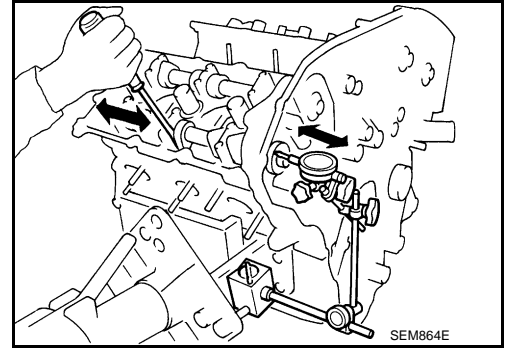

- Measure the following parts if out of the limit.

- Dimension "A" for camshaft No. 1 journal

Standard : 27.500 - 27.548 mm (1.0827 - 1.0846 in)

- Dimension "B" for cylinder head No. 1 journal bearing

Standard : 27.360 - 27.385 mm (1.0772 - 1.0781 in)

- Refer to the standards above, and then replace camshaft and/or cylinder head.

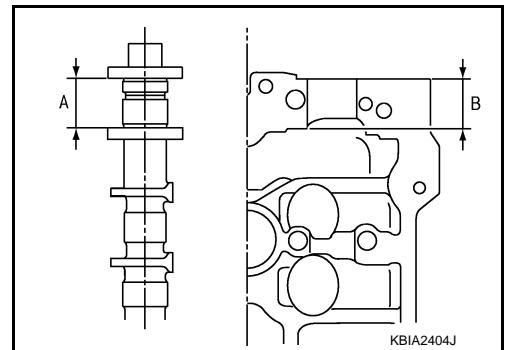

Camshaft Sprocket Runout

1. Put V-block on precise flat table, and support No. 2 and 4 journals of camshaft.

CAUTION:

Never support No. 1 journal (on the side of camshaft sprocket) because it has a different diameter from the other three locations.

2. Measure the camshaft sprocket runout with a dial indicator. (Total indicator reading)

Limit : Refer to [EM-143, "Camshaft"](#).

- If it exceeds the limit, replace camshaft sprocket.

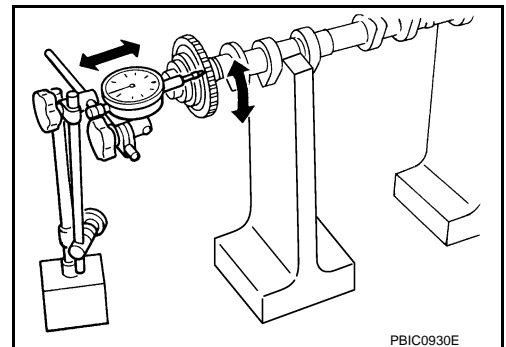

Valve Lifter

CAMSHAFT

[VQ35HR]

< REMOVAL AND INSTALLATION >

Check if surface of valve lifter has any wear or cracks.

- If anything above is found, replace valve lifter. Refer to [EM-143](#), "[Camshaft](#)".

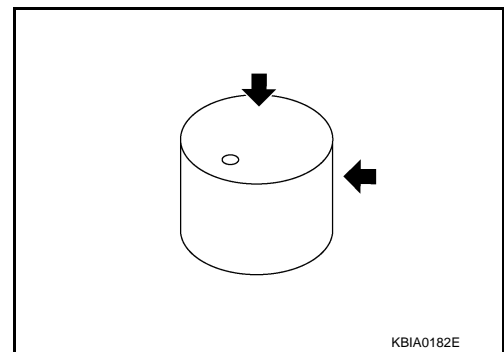

Valve Lifter Clearance

VALVE LIFTER OUTER DIAMETER

- Measure the outer diameter at 1/2 height of valve lifter with a micrometer (A) since valve lifter is in barrel shape.

Standard (Intake and exhaust) : Refer to [EM-143](#), "[Camshaft](#)".

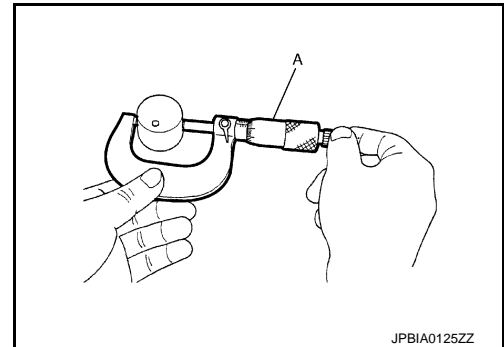

VALVE LIFTER HOLE DIAMETER

- Measure the inner diameter of valve lifter hole of cylinder head with an inside micrometer.

Standard (Intake and exhaust) : Refer to [EM-143](#), "[Camshaft](#)".

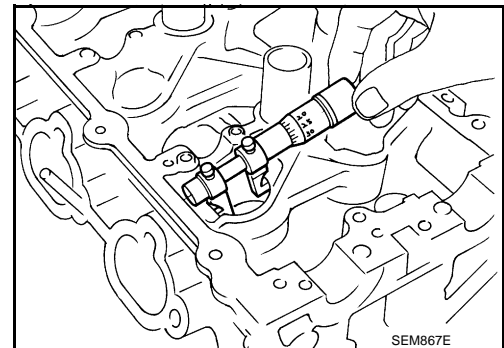

VALVE LIFTER CLEARANCE

- (Valve lifter clearance) = (Valve lifter hole diameter) – (Valve lifter outer diameter)

Standard (Intake and exhaust) : Refer to [EM-143](#), "[Camshaft](#)".

- If the calculated value is out of the standard, referring to each standard of valve lifter outer diameter and valve lifter hole diameter, replace either or both valve lifter and cylinder head.

INSPECTION AFTER INSTALLATION

Inspection of Camshaft Sprocket (INT) Oil Groove

CAUTION:

- Perform this inspection only when DTC P0011 and P0021 are detected in self-diagnostic results of CONSULT-III and it is directed according to inspection procedure of EC section. Refer to [EC-111](#), "[Diagnosis Description](#)".
 - Check when engine is cold so as to prevent burns from the splashing engine oil.
1. Check engine oil level. Refer to [LU-6](#), "[Inspection](#)".
 2. Perform the following procedure so as to prevent the engine from being unintentionally started while checking.
 - a. Release the fuel pressure. Refer to [EC-567](#), "[Inspection](#)".

CAMSHAFT

< REMOVAL AND INSTALLATION >

[VQ35HR]

- b. Disconnect ignition coil and injector harness connectors. Refer to [EM-50, "Exploded View"](#) and [EM-40, "Exploded View"](#).
3. Remove intake valve timing control solenoid valve. Refer to [EM-53, "Exploded View"](#).
4. Crank engine, and then check that engine oil comes out from intake valve timing control solenoid valve hole (A). End crank after checking.

1 : Valve timing control cover (bank 1)

⇐ : Engine front

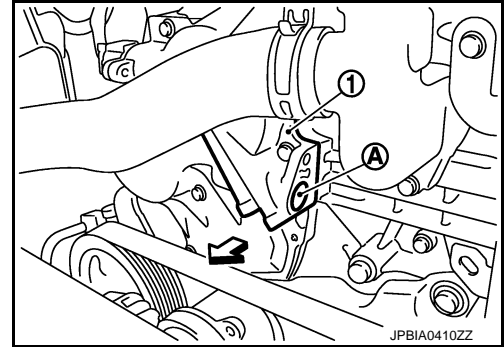

WARNING:

Be careful not to touch rotating parts. (drive belt, idler pulley, and crankshaft pulley, etc.)

CAUTION:

- Prevent splashing by using a shop cloth so as to prevent the worker from injury from engine oil and so as to prevent engine oil contamination.
 - Prevent splashing by using a shop cloth so as to prevent engine oil from being splashed to engine and vehicle. Especially, be careful no to apply engine oil to rubber parts of drive belt, engine mounting insulator, etc. Wipe engine oil off immediately if it is splashed.
5. Perform the following inspection if engine oil does not come out from intake valve timing control solenoid valve oil hole of the cylinder head.
 - Remove oil filter, and then clean it. Refer to [EM-53, "Exploded View"](#).
 - Clean oil groove between oil strainer and intake valve timing control solenoid valve. Refer to [LU-3, "Engine Lubrication System"](#) and [LU-3, "Engine Lubrication System Schematic"](#).
 6. Remove components between intake valve timing control solenoid valve and camshaft sprocket (INT), and then check each oil groove for clogging.
 - Clean oil groove if necessary. Refer to [LU-3, "Engine Lubrication System"](#) and [LU-3, "Engine Lubrication System Schematic"](#).
 7. After inspection, install removed parts in the reverse order.

Inspection for Leakage

The following are procedures for checking fluids leakage, lubricates leakage.

- Before starting engine, check oil/fluid levels including engine coolant and engine oil. If less than required quantity, fill to the specified level. Refer to [MA-12, "Fluids and Lubricants"](#).
- Use procedure below to check for fuel leakage.
 - Turn ignition switch "ON" (with engine stopped). With fuel pressure applied to fuel piping, check for fuel leakage at connection points.
 - Start engine. With engine speed increased, check again for fuel leakage at connection points.
- Run engine to check for unusual noise and vibration.

NOTE:

If hydraulic pressure inside timing chain tensioner drops after removal/installation, slack in the guide may generate a pounding noise during and just after engine start. However, this is normal. Noise will stop after hydraulic pressure rises.

- Warm up engine thoroughly to check there is no leakage of fuel, or any oil/fluids including engine oil and engine coolant.
- Bleed air from lines and hoses of applicable lines, such as in cooling system.
- After cooling down engine, again check oil/fluid levels including engine oil and engine coolant. Refill to the specified level, if necessary.

Summary of the inspection items:

Items	Before starting engine	Engine running	After engine stopped
Engine coolant	Level	Leakage	Level
Engine oil	Level	Leakage	Level
Other oils and fluid*	Level	Leakage	Level
Fuel	Leakage	Leakage	Leakage

*: Transmission/transaxle/CVT fluid, power steering fluid, brake fluid, etc.

OIL SEAL VALVE OIL SEAL

VALVE OIL SEAL : Removal and Installation

INFOID:000000003887365

A

EM

REMOVAL

1. Remove camshaft relating to valve oil seal to be removed. Refer to [EM-107. "Exploded View"](#).
2. Remove valve lifters. Refer to [EM-70. "Exploded View"](#).
3. Turn crankshaft until the cylinder requiring new oil seals is at TDC. This will prevent valve from dropping into cylinder.
4. Remove valve collet.

- Compress valve spring with the valve spring compressor [SST: KV10116200 (J-26336-A)] (A), the attachment [SST: KV10115900 (J-26336-20)] (C), the adapter [SST: KV10109220 (—)] (B). Remove valve collet with a magnet hand.

CAUTION:

When working, take care not to damage valve lifter holes.

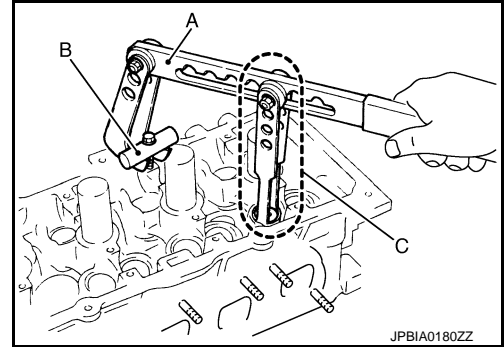

5. Remove valve spring retainer, and valve spring.
6. Remove valve oil seal using the valve oil seal puller [SST: KV10107902 (J-38959)] (A).

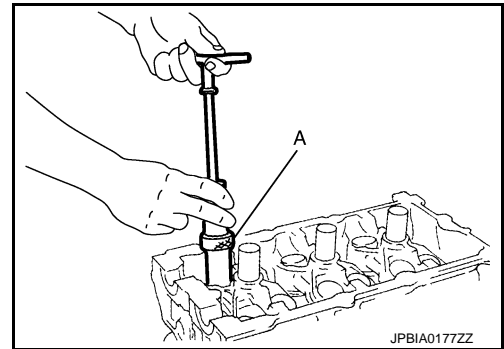

INSTALLATION

1. Apply new engine oil on new valve oil seal joint and seal lip.
2. Using the valve oil seal drift [SST: KV10115600 (J-38958)] (A), press fit valve seal to height (b) shown in the figure.

NOTE:

Dimension: Height measured before valve spring seat installation

Intake and exhaust : 14.3 - 14.9 mm (0.563 - 0.587 in)

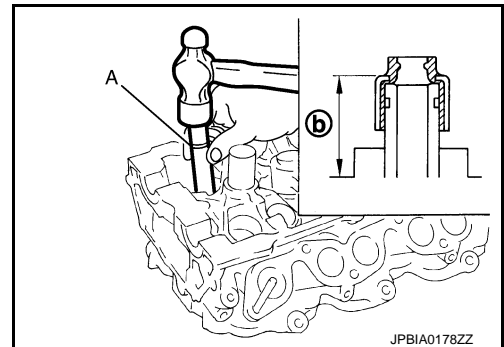

3. Install in the reverse order of removal after this step.

FRONT OIL SEAL

FRONT OIL SEAL : Removal and Installation

INFOID:000000003887366

REMOVAL

C

D

E

F

G

H

I

J

K

L

M

N

O

P

OIL SEAL

< REMOVAL AND INSTALLATION >

[VQ35HR]

1. Remove the following parts:
 - Engine undercover with power tool.
 - Drive belt: Refer to [EM-15. "Exploded View"](#).
 - Crankshaft pulley: Refer to [EM-53. "Exploded View"](#).
2. Remove front oil seal using a suitable tool.

CAUTION:

Be careful not to damage front timing chain case and crankshaft.

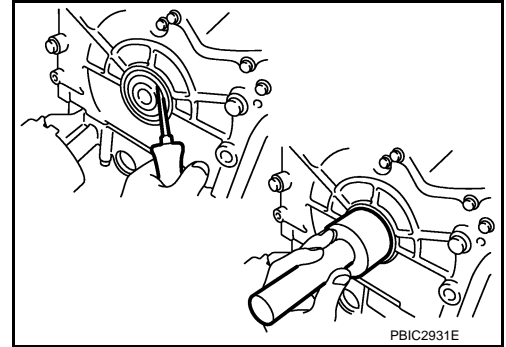

INSTALLATION

1. Apply new engine oil to both oil seal lip and dust seal lip of new front oil seal.
2. Install front oil seal.
 - Install front oil seal so that each seal lip is oriented as shown in the figure.

- A : Oil seal lip
- B : Dust seal lip
- ⇐ : Engine inside
- ⇠ : Engine outside

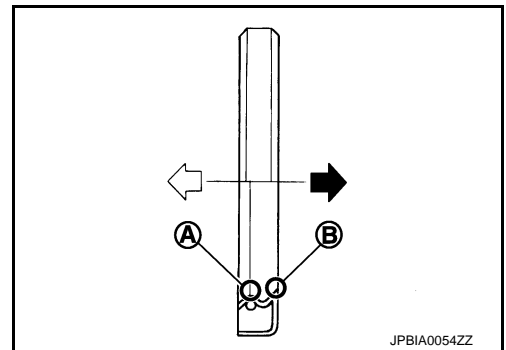

- Using a suitable drift, press-fit until the height of front oil seal is level with the mounting surface.
- Suitable drift: outer diameter 60 mm (2.36 in), inner diameter 50 mm (1.97 in).
- Check the garter spring is in position and seal lips are not inverted

CAUTION:

- **Be careful not to damage front timing chain case and crankshaft.**
- **Press-fit straight and avoid causing burrs or tilting oil seal.**

3. Install in the reverse order of removal after this step.

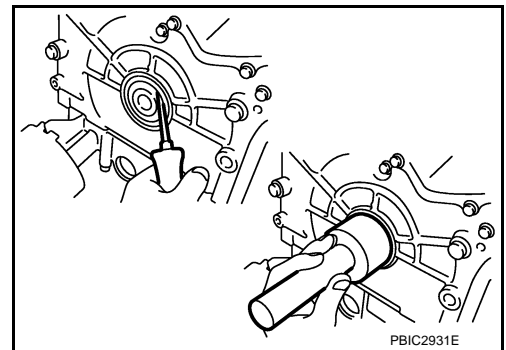

REAR OIL SEAL

REAR OIL SEAL : Removal and Installation

INFOID:000000003887367

REMOVAL

1. Remove transmission assembly. Refer to [TM-199. "2WD : Exploded View"](#) (2WD models) or [TM-202. "AWD : Exploded View"](#) (AWD models).
2. Remove drive plate. Refer to [EM-117. "Exploded View"](#).
3. Remove rear oil seal with a suitable tool.

CAUTION:

OIL SEAL

< REMOVAL AND INSTALLATION >

[VQ35HR]

Be careful not to damage crankshaft and cylinder block.

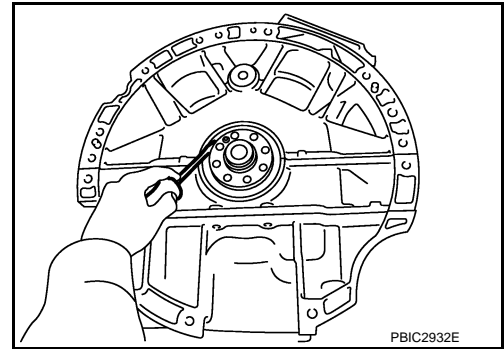

INSTALLATION

1. Install rear oil seal.

- Install rear oil seal so that each seal lip is oriented as shown in the figure.

- A : Oil seal lip
- B : Dust seal lip
- ⇐ : Engine inside
- ➡ : Engine outside

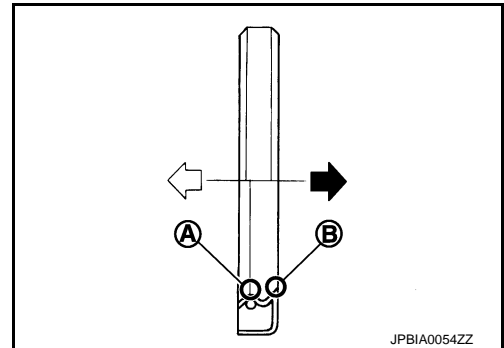

- Press in rear oil seal (1) to the position as shown in the figure.

- B : Cylinder block rear end face
- a : 0 - 0.5 mm (0 - 0.020 in)

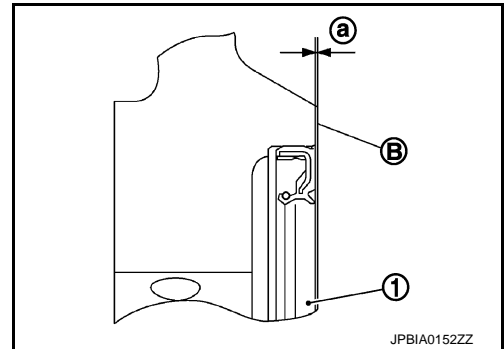

- Using a suitable drift (A), press-fit until the height of rear oil seal is level with the mounting surface.
- Suitable drift: outer diameter 100 mm (3.94 in), inner diameter 85 mm (3.35 in).

CAUTION:

- Be careful not to damage crankshaft and cylinder block.
- Press-fit straight and avoid causing burrs or tilting oil seal.

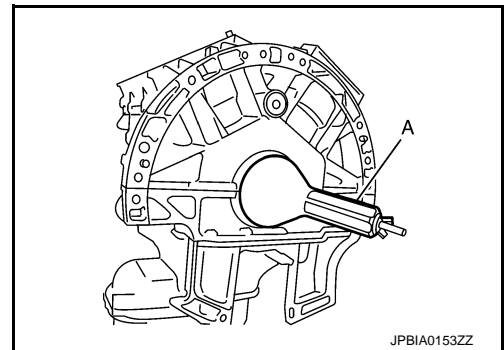

2. Install in the reverse order of removal after this step.

ENGINE ASSEMBLY

< UNIT REMOVAL AND INSTALLATION >

[VQ35HR]

UNIT REMOVAL AND INSTALLATION

ENGINE ASSEMBLY

2WD

2WD : Exploded View

INFOID:000000003887368

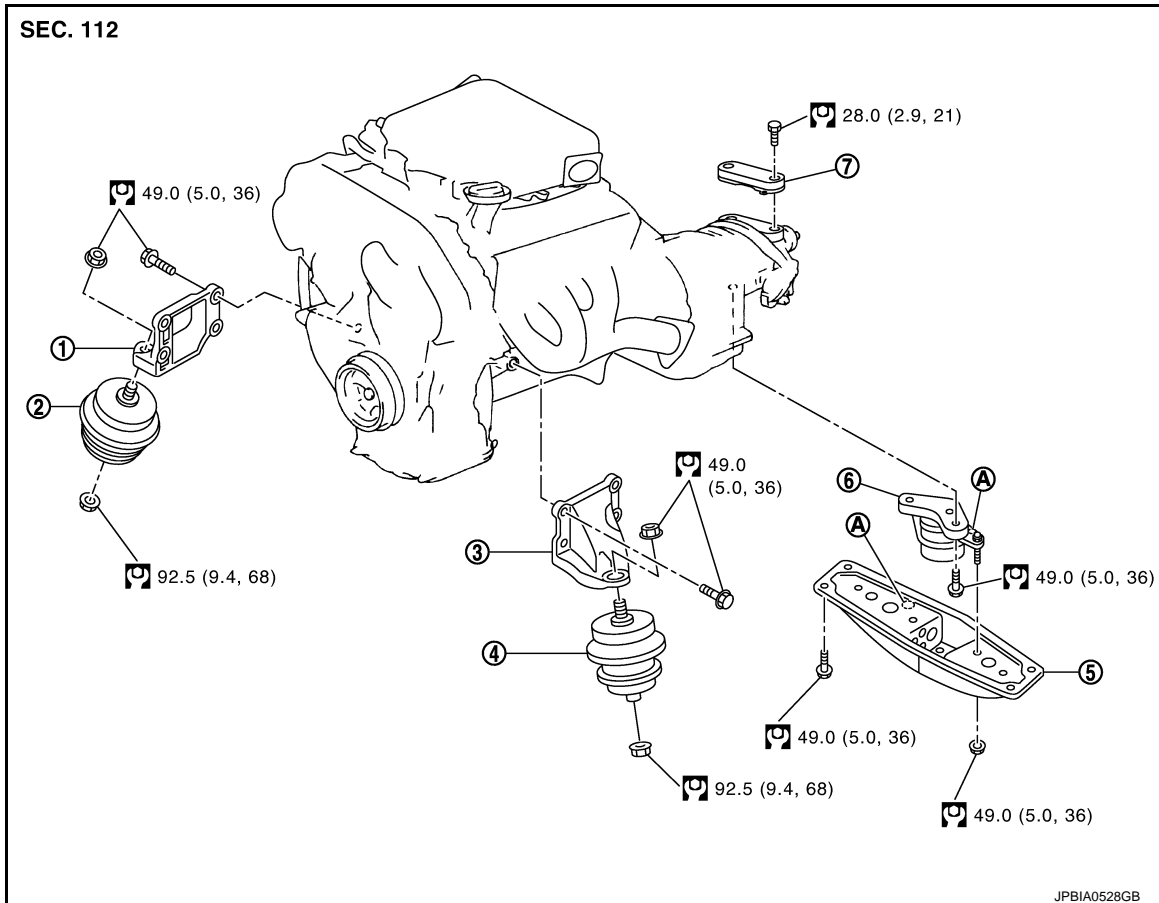

- | | | |
|-----------------------------------|-----------------------------------|-------------------------------------|
| 1. Engine mounting bracket (RH) | 2. Engine mounting insulator (RH) | 3. Engine mounting bracket (LH) |
| 4. Engine mounting insulator (LH) | 5. Rear engine mounting member | 6. Engine mounting insulator (rear) |
| 7. Dynamic damper | | |
| A. Front mark | | |

Refer to [GI-4, "Components"](#) for symbols in the figure.

2WD : Removal and Installation

INFOID:000000003887369

WARNING:

- Situate the vehicle on a flat and solid surface.
- Place chocks at front and back of rear wheels.
- For engines not equipped with engine slingers, attach proper slingers and bolts described in PARTS CATALOG.

CAUTION:

- Always be careful to work safely, avoid forceful or uninstructed operations.
- Never start working until exhaust system and engine coolant are cool enough.
- If items or work required are not covered by the engine section, refer to the applicable sections.
- Always use the support point specified for lifting.
- Use either 2-pole lift type or separate type lift as best you can. If board-on type is used for unavoidable reasons, support at rear axle jacking point with transmission jack or similar tool before starting work, in preparation for the backward shift of center of gravity.

ENGINE ASSEMBLY

< UNIT REMOVAL AND INSTALLATION >

[VQ35HR]

- For supporting points for lifting and jacking point at rear axle, refer to [GI-26, "Garage Jack and Safety Stand and 2-Pole Lift"](#).

REMOVAL

Outline

At first, remove the engine and the transmission assembly with front suspension member downward. Then separate the engine from transmission.

Preparation

1. Release fuel pressure. Refer to [EC-567, "Inspection"](#).
2. Disconnect both battery cables. Refer to [PG-120, "Exploded View"](#).
3. Drain engine coolant from radiator. Refer to [CO-8, "Draining"](#).
CAUTION:
 - Perform this step when engine is cold.
 - Never spill engine coolant on drive belt.
4. Remove the following parts:
 - Radiator reservoir tank: Refer to [CO-14, "Exploded View"](#).
 - Engine cover: Refer to [EM-27, "Exploded View"](#).
 - Front road wheel and tires (power tool)
 - Engine undercover (power tool)
 - Front cross bar: Refer to [FSU-15, "Exploded View"](#).
 - Cowl top cover: Refer to [EXT-22, "Exploded View"](#).
 - Air duct and air cleaner case assembly: Refer to [EM-29, "Exploded View"](#).
5. Discharge refrigerant from A/C circuit. Refer to [HA-25, "Collection and Charge"](#).
6. Remove radiator hoses (upper and lower). Refer to [CO-14, "Exploded View"](#).

Engine Room LH

1. Disconnect heater hose from vehicle-side, and fit a plug onto hose end to prevent engine coolant leakage.
2. Disconnect A/C piping from A/C compressor, and temporarily fasten it on vehicle with a rope. Refer to [HA-40, "Exploded View"](#).
3. Disconnect brake booster vacuum hose.
4. Disconnect ground cable.

Engine Room RH

1. Disconnect battery positive cable at vehicle side and temporarily fasten it on engine.
2. Disconnect all clips and connector of the engine room harness from engine back side.
3. Disconnect fuel feed hose (with damper) and EVAP hose. Refer to [EM-40, "Exploded View"](#).
CAUTION:
Fit plugs onto disconnected hoses to prevent fuel leakage.
4. Remove reservoir tank of power steering oil pump and piping from vehicle, and temporarily secure them on engine. Refer to [ST-47, "VQ35HR : Exploded View"](#).
CAUTION:
When temporarily securing, keep the reservoir tank upright to avoid a fluid leakage.

Vehicle Inside

Follow procedure below to disconnect engine room harness connectors at passenger room side, and temporarily secure them on engine.

1. Remove passenger-side kicking plate and dash side finisher. Refer to [INT-17, "Exploded View"](#).
2. Disconnect engine room harness connectors at unit sides and other.
3. Disengage intermediate fixing point. Pull out engine room harnesses to engine room side, and temporarily secure them on engine.
CAUTION:
 - When pulling out harnesses, take care not to damage harnesses and connectors.
 - After temporarily securing, cover connectors with vinyl or similar material to protect against foreign material adhesion.

Vehicle Underbody

1. Remove A/T fluid cooler hoses and power steering oil pump oil cooler hoses.

ENGINE ASSEMBLY

< UNIT REMOVAL AND INSTALLATION >

[VQ35HR]

- Install plug to avoid leakage of A/T fluid and power steering fluid.
2. Disconnect heated oxygen sensor 2 harness.
3. Remove three way catalyst and exhaust front tube. Refer to [EX-5, "Exploded View"](#).
4. Disconnect steering lower joint at power steering gear assembly side, and release steering lower shaft. Refer to [ST-17, "WITHOUT ELECTRIC MOTOR : Exploded View"](#) or [ST-20, "WITH ELECTRIC MOTOR : Exploded View"](#).
5. Remove rear propeller shaft. Refer to [DLN-116, "Exploded View"](#).
6. Disengage A/T control rod at A/T shift selector side. Then, temporarily secure it on the transmission assembly, so that it does not sag. Refer to [TM-187, "Exploded View"](#).
7. Preparation for the separation work of transaxle is as per the following:
 - Remove rear plate cover from oil pan (upper). Then remove bolts fixing drive plate to torque converter. Refer to [EM-188, "Exploded View"](#).
 - Remove transmission joint bolts that pierce at oil pan (upper) lower rear side. Refer to [EM-188, "Exploded View"](#).
8. Remove front stabilizer connecting rod from transverse link. Refer to [FSU-17, "Exploded View"](#).
9. Remove lower ends of left and right steering knuckle from transverse link. Refer to [FSU-13, "Exploded View"](#).
10. Separate steering outer sockets from steering knuckle. Refer to [ST-25, "Exploded View"](#).
11. Remove transverse links mounting bolts at suspension member side. Refer to [FSU-13, "Exploded View"](#).

Removal Work

1. Use a manual lift table caddy (commercial service tool) or an equivalently rigid tool such as a transmission jack. Securely support bottom of suspension member and the transmission assembly.

CAUTION:

Put a piece of wood or something similar as the supporting surface, secure a completely stable condition.

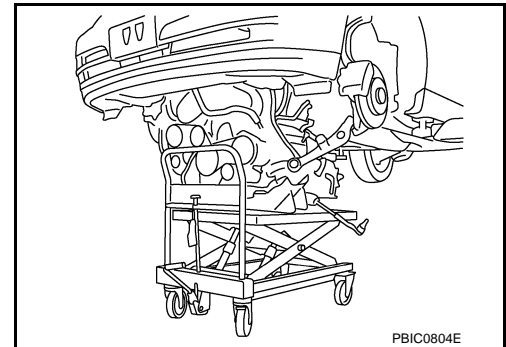

2. Remove rear engine mounting member bolts.
3. Remove front suspension member mounting bolts and nuts. Refer to [FSU-18, "Exploded View"](#).
4. Carefully lower jack, or raise lift to remove the engine, the transmission assembly and front suspension member. When performing work, observe the following caution:

CAUTION:

- Confirm there is no interference with the vehicle.
- Check that all connection points have been disconnected.
- Keep in mind the center of vehicle gravity changes. If necessary, use jack(s) to support the vehicle at rear jacking point(s) to prevent it from falling off the lift.

Separation Work

1. Install engine slingers into front of cylinder head (bank 1) and rear of cylinder head (bank 2).

- 1 : Engine front slinger
- 2 : Engine rear upper slinger
- 3 : Spacer
- 4 : Engine rear lower slinger
- A : Bank 1
- B : Bank 2
- ⇐ : Engine front

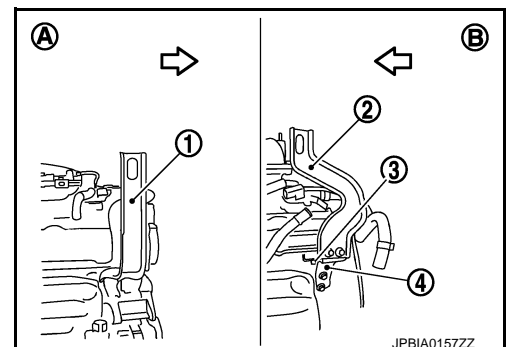

Slinger bolts:

: 28.0 N-m (2.9 kg-m, 21 ft-lb)

- To protect rocker cover against damage caused by tilting of engine slinger, insert spacer between cylinder head and engine rear lower slinger (3), in direction shown in the figure.

1 : Engine rear upper slinger

 : Engine front

NOTE:

Spacer (2) is a component part of engine rear upper slinger assembly.

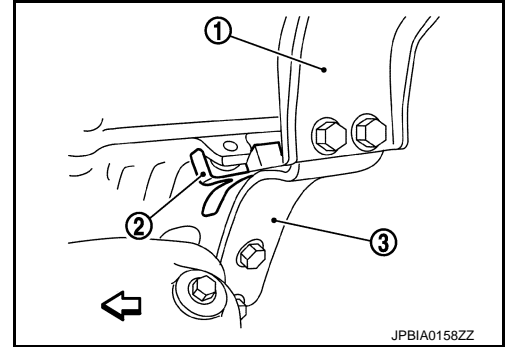

- Remove power steering oil pump from engine side. Refer to [ST-35, "VQ35HR : Exploded View"](#).
 - Remove engine mounting insulators (RH and LH) under side nuts with power tool.
 - Lift with hoist and separate the engine and the transmission assembly from front suspension member.
- CAUTION:**
- Before and during this lifting, always check that any harnesses are left connected.**
 - Never damage to and oil/grease smearing or spills onto engine mounting insulator.**
- Remove alternator. Refer to [CHG-25, "VQ35HR : Exploded View"](#).
 - Remove starter motor. Refer to [STR-17, "VQ35HR : Exploded View"](#).
 - Separate the engine from the transmission assembly. Refer to [TM-199, "2WD : Exploded View"](#).
 - Remove each engine mounting insulator and each engine mounting bracket from the engine with power tool.

INSTALLATION

Note the following item, and install in the reverse order of removal.

- Do not allow engine mounting insulator to be damage and careful no oil gets on it.
- For a location with a positioning pin, insert it securely into hole of mating part.
- For a part with a specified installation orientation, refer to component figure in [EM-82, "2WD : Exploded View"](#).
- When installing engine mounting bracket (RH and LH) on cylinder block, tighten two upper bolts [shown as (A) in the figure] first. Then tighten two lower bolts [shown as (B) in the figure].

 : Engine front

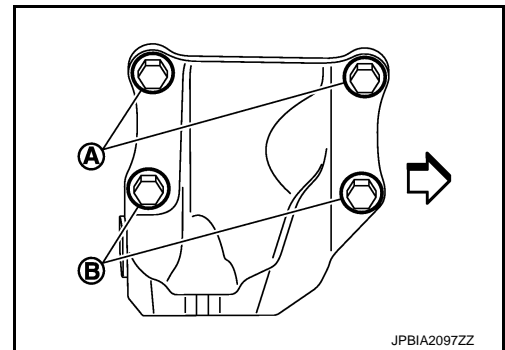

- Check all engine mounting insulators are seated properly, then tighten mounting nuts.
- Tighten rear engine mounting member bolts in numerical order as shown in the figure.

 : Vehicle front

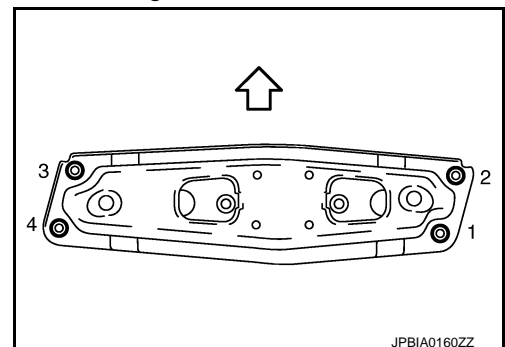

ENGINE ASSEMBLY

< UNIT REMOVAL AND INSTALLATION >

[VQ35HR]

2WD : Inspection

INFOID:000000003887370

INSPECTION AFTER INSTALLATION

Inspection for Leakage

The following are procedures for checking fluids leakage, lubricates leakage and exhaust gases leakage.

- Before starting engine, check oil/fluid levels including engine coolant and engine oil. If less than required quantity, fill to the specified level. Refer to [MA-12. "Fluids and Lubricants"](#).
- Use procedure below to check for fuel leakage.
 - Turn ignition switch "ON" (with engine stopped). With fuel pressure applied to fuel piping, check for fuel leakage at connection points.
 - Start engine. With engine speed increased, check again for fuel leakage at connection points.
- Run engine to check for unusual noise and vibration.
- Warm up engine thoroughly to check there is no leakage of fuel, exhaust gases, or any oil/fluids including engine oil and engine coolant.
- Bleed air from lines and hoses of applicable lines, such as in cooling system.
- After cooling down engine, again check oil/fluid levels including engine oil and engine coolant. Refill to the specified level, if necessary.

Summary of the inspection items:

Items	Before starting engine	Engine running	After engine stopped
Engine coolant	Level	Leakage	Level
Engine oil	Level	Leakage	Level
Other oils and fluid*	Level	Leakage	Level
Fuel	Leakage	Leakage	Leakage
Exhaust gases	—	Leakage	—

*: Transmission/transaxle/CVT fluid, power steering fluid, brake fluid, etc.

AWD

ENGINE ASSEMBLY

< UNIT REMOVAL AND INSTALLATION >

[VQ35HR]

AWD : Exploded View

INFOID:000000003887371

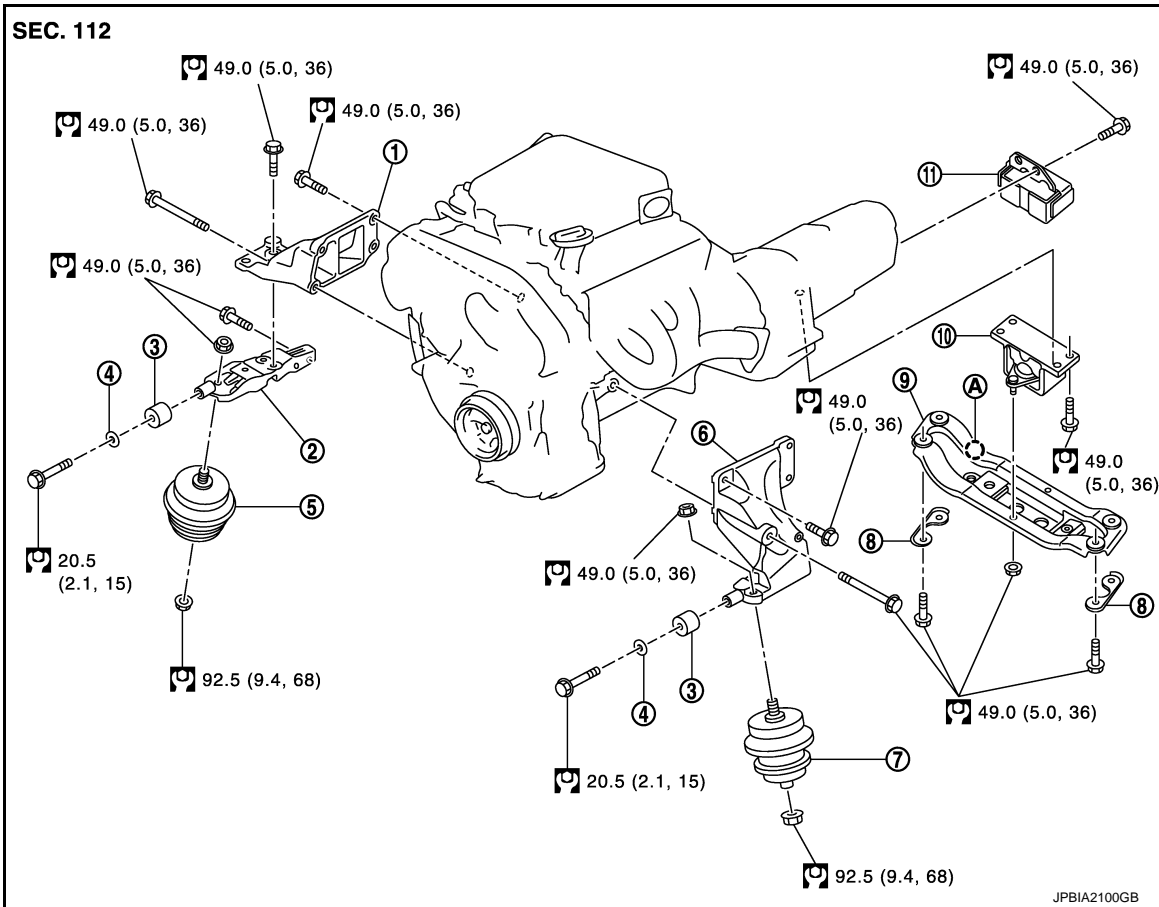

- | | | |
|--------------------------------------|---|---------------------------------|
| 1. Engine mounting bracket (RH) | 2. Engine mounting bracket (RH) (lower) | 3. Dynamic damper |
| 4. Washer | 5. Engine mounting insulator (RH) | 6. Engine mounting bracket (LH) |
| 7. Engine mounting insulator (LH) | 8. Heat insulator | 9. Rear engine mounting member |
| 10. Engine mounting insulator (rear) | 11. Dynamic damper | |
- A. Front mark

Refer to [GI-4, "Components"](#) for symbols in the figure.

AWD : Removal and Installation

INFOID:000000003887372

WARNING:

- Situate the vehicle on a flat and solid surface.
- Place chocks at front and back of rear wheels.
- For engines not equipped with engine slingers, attach proper slingers and bolts described in PARTS CATALOG.

CAUTION:

- Always be careful to work safely, avoid forceful or uninstructed operations.
- Never start working until exhaust system and engine coolant are cool enough.
- If items or work required are not covered by the engine section, refer to the applicable sections.
- Always use the support point specified for lifting.
- Use either 2-pole lift type or separate type lift as best you can. If board-on type is used for unavoidable reasons, support at rear axle jacking point with transmission jack or similar tool before starting work, in preparation for the backward shift of center of gravity.
- For supporting points for lifting and jacking point at rear axle, refer to [GI-26, "Garage Jack and Safety Stand and 2-Pole Lift"](#).

REMOVAL

ENGINE ASSEMBLY

[VQ35HR]

< UNIT REMOVAL AND INSTALLATION >

Outline

At first, remove the engine, the transmission assembly, the transfer assembly and the front final drive assembly with front suspension member downward. Then separate the engine, the transmission assembly, the transfer and the front final drive assembly.

Preparation

1. Release fuel pressure. Refer to [EC-567, "Inspection"](#).
2. Disconnect both battery terminals. Refer to [PG-120, "Exploded View"](#).
3. Drain engine coolant from radiator. Refer to [CO-8, "Draining"](#).
CAUTION:
 - Perform this step when engine is cold.
 - Never spill engine coolant on drive belt.
4. Remove the following parts:
 - Radiator reservoir tank: Refer to [CO-14, "Exploded View"](#).
 - Engine cover: Refer to [EM-27, "Exploded View"](#).
 - Front road wheel and tires (power tool)
 - Engine undercover (power tool)
 - Front cross bar: Refer to [FSU-15, "Exploded View"](#).
 - Cowl top cover: Refer to [EXT-22, "Exploded View"](#).
 - Air duct and air cleaner case assembly: Refer to [EM-29, "Exploded View"](#).
5. Discharge refrigerant from A/C circuit. Refer to [HA-25, "Collection and Charge"](#).
6. Remove radiator hoses (upper and lower). Refer to [CO-14, "Exploded View"](#).

Engine Room LH

1. Disconnect heater hose from vehicle-side, and fit a plug onto hose end to prevent engine coolant leakage.
2. Disconnect A/C piping from A/C compressor, and temporarily fasten it on vehicle with a rope. Refer to [HA-40, "Exploded View"](#).
3. Disconnect brake booster vacuum hose.
4. Disconnect ground cables.

Engine Room RH

1. Disconnect battery positive cable vehicle side and temporarily fasten it on engine.
2. Disconnect all clips and connectors of the engine room harness from engine back side.
3. Disconnect fuel feed hose (with damper) and EVAP hose. Refer to [EM-40, "Exploded View"](#).
CAUTION:
Fit plugs onto disconnected hoses to prevent fuel leakage.
4. Remove reservoir tank of power steering oil pump and piping from vehicle, and temporarily secure them on engine. Refer to [ST-47, "VQ35HR : Exploded View"](#).
CAUTION:
When temporarily securing, keep the reservoir tank upright to avoid a fluid leakage.

Vehicle Inside

Follow procedure below to disconnect engine room harness connectors at passenger room side, and temporarily secure them on engine.

1. Remove passenger-side kicking plate and dash side finisher. Refer to [INT-17, "Exploded View"](#).
2. Disconnect engine room harness connectors at unit sides and other.
3. Disengage intermediate fixing point. Pull out engine room harnesses to engine room side, and temporarily secure them on engine.
CAUTION:
 - When pulling out harnesses, take care not to damage harnesses and connectors.
 - After temporarily securing, cover connectors with vinyl or similar material to protect against foreign material adhesion.

Vehicle Underbody

1. Remove A/T fluid cooler hoses and power steering oil pump oil cooler hoses.
 - Install plug to avoid leakage of A/T fluid and power steering fluid.
2. Disconnect heated oxygen sensor 2 harness. Refer to [EM-36, "Exploded View"](#).
3. Remove three way catalyst and exhaust front tube. Refer to [EX-5, "Exploded View"](#).

ENGINE ASSEMBLY

< UNIT REMOVAL AND INSTALLATION >

[VQ35HR]

4. Disconnect steering lower joint at power steering gear assembly side, and release steering lower shaft. Refer to [ST-17, "WITHOUT ELECTRIC MOTOR : Exploded View"](#) or [ST-20, "WITH ELECTRIC MOTOR : Exploded View"](#).
5. Remove rear propeller shaft. Refer to [DLN-116, "Exploded View"](#).
6. Remove front drive shaft (both side). Refer to [FAX-26, "Exploded View"](#).
7. Disengage A/T control rod at A/T shift selector side. Then, temporarily secure it on the transmission assembly, so that it does not sag. Refer to [TM-187, "Exploded View"](#).
8. Preparation for the separation work of transaxle is as per the following:
 - Remove rear plate cover from oil pan (upper). Then remove bolts fixing drive plate to torque converter. Refer to [EM-46, "Exploded View"](#).
 - Remove transmission joint bolts that pierce at oil pan (upper) lower rear side. Refer to [EM-46, "Exploded View"](#).
9. Remove front stabilizer connecting rod from transverse link. Refer to [FSU-36, "Exploded View"](#).
10. Remove lower ends of left and right steering knuckle from transverse link. Refer to [FSU-13, "Exploded View"](#).
11. Separate steering outer sockets from steering knuckle. Refer to [ST-25, "Exploded View"](#).
12. Remove transverse links mounting bolts at suspension member side. Refer to [FSU-13, "Exploded View"](#).

Removal Work

1. Use a manual lift table caddy (commercial service tool) or an equivalently rigid tool such as a transmission jack. Securely support bottom of suspension member and transmission.

CAUTION:

Put a piece of wood or something similar as the supporting surface, secure a completely stable condition.

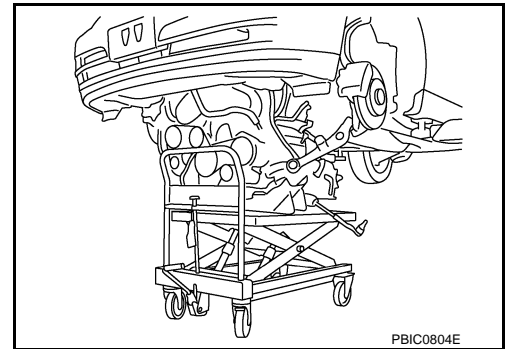

2. Remove rear engine mounting member bolts.
3. Remove front suspension member mounting bolts and nuts. Refer to [FSU-37, "Exploded View"](#).
4. Carefully lower jack, or raise lift to remove the engine, transmission, transfer and front final drive assembly and front suspension member. When performing work, observe the following caution:

CAUTION:

- Confirm there is no interference with the vehicle.
- Check that all connection points have been disconnected.
- Keep in mind the center of the vehicle gravity changes. If necessary, use jack(s) to support the vehicle at rear jacking point(s) to prevent it from falling off the lift.

Separation Work

1. Install engine slingers into front of cylinder head (bank 1) and rear of cylinder head (bank 2).

- 1 : Engine front slinger
- 2 : Engine rear upper slinger
- 3 : Spacer
- 4 : Engine rear lower slinger
- A : Bank 1
- B : Bank 2
- ⇐ : Engine front

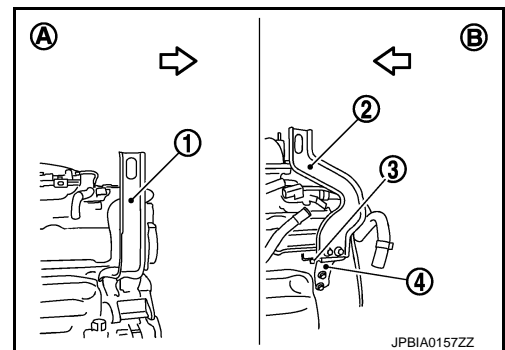

Slinger bolts:

: 28.0 N·m (2.9 kg·m, 21 ft·lb)

ENGINE ASSEMBLY

[VQ35HR]

< UNIT REMOVAL AND INSTALLATION >

- To protect rocker cover against damage caused by tilting of engine slinger, insert spacer between cylinder head and engine rear lower slinger (3), in direction shown in the figure.

1 : Engine rear upper slinger

⇐ : Engine front

NOTE:

Spacer (2) is a component part of engine rear upper slinger assembly.

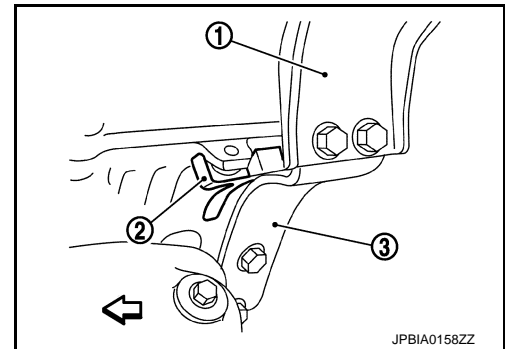

- Remove power steering oil pump from engine side. Refer to [ST-35, "VQ35HR : Exploded View"](#).
- Remove engine mounting insulators (RH and LH) under side nuts with power tool.
- Lift with hoist and separate the engine, the transmission assembly, the transfer assembly and the front final drive assembly from front suspension member.
CAUTION:
 - Before and during this lifting, always check if any harnesses are left connected.
 - Never damage to and oil/grease smearing or spills onto engine mounting insulator.
- Remove alternator. Refer to [CHG-25, "VQ35HR : Exploded View"](#).
- Remove starter motor. Refer to [STR-17, "VQ35HR : Exploded View"](#).
- Remove front propeller shaft from the front final drive assembly side. Refer to [DLN-107, "VQ35HR : Exploded View"](#).
- Separate the engine from the transmission assembly. Refer to [TM-202, "AWD : Exploded View"](#).
- Remove the front final drive assembly from oil pan (upper). Refer to [DLN-148, "VQ35HR : Exploded View"](#).
- Remove each engine mounting insulator and each engine mounting bracket from the engine with power tool.

INSTALLATION

Note the following item, and install in the reverse order of removal.

- Do not allow engine mounting insulator to be damage and careful no engine oil gets on it.
- For a location with a positioning pin, insert it securely into hole of mating part.
- For a part with a specified installation orientation, refer to component figure in [EM-87, "AWD : Exploded View"](#).
- When installing engine mounting bracket (RH and LH) on cylinder block, tighten two upper bolts (B) first. Then tighten two lower bolts (C).

3 : Engine mounting bracket (LH)

A : Right side

G : Left side

- Install engine mounting bracket (RH) (lower) (2) as per the following:
 - Temporarily tighten mounting bolts [shown as (D), (E) and (F) in the figure].
 - Tighten mounting bolts to the specified torque with following mounting surfaces touched.
- Engine mounting bracket (RH) (1) to engine mounting bracket (RH) (lower) [shown as and in figure].
- Front final drive to engine mounting bracket (RH) (lower) [shown as in figure].
- Check all engine mounting insulators are seated properly, then tighten mounting nuts.

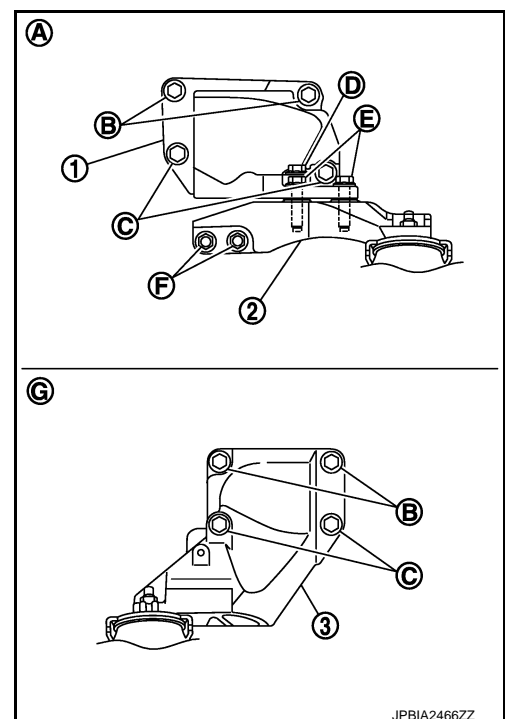

ENGINE ASSEMBLY

< UNIT REMOVAL AND INSTALLATION >

[VQ35HR]

- Tighten rear engine mounting member bolts in numerical order as shown in the figure.

↶ : Vehicle front

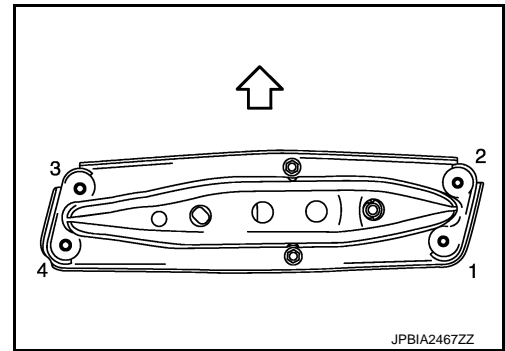

INFOID:000000003887373

AWD : Inspection

INSPECTION AFTER INSTALLATION

Inspection for Leakage

The following are procedures for checking fluids leakage, lubricates leakage and exhaust gases leakage.

- Before starting engine, check oil/fluid levels including engine coolant and engine oil. If less than required quantity, fill to the specified level. Refer to [MA-12, "Fluids and Lubricants"](#).
- Use procedure below to check for fuel leakage.
 - Turn ignition switch "ON" (with engine stopped). With fuel pressure applied to fuel piping, check for fuel leakage at connection points.
 - Start engine. With engine speed increased, check again for fuel leakage at connection points.
- Run engine to check for unusual noise and vibration.
- Warm up engine thoroughly to check there is no leakage of fuel, exhaust gases, or any oil/fluids including engine oil and engine coolant.
- Bleed air from lines and hoses of applicable lines, such as in cooling system.
- After cooling down engine, again check oil/fluid levels including engine oil and engine coolant. Refill to the specified level, if necessary.

Summary of the inspection items:

Items	Before starting engine	Engine running	After engine stopped
Engine coolant	Level	Leakage	Level
Engine oil	Level	Leakage	Level
Other oils and fluid*	Level	Leakage	Level
Fuel	Leakage	Leakage	Leakage
Exhaust gases	—	Leakage	—

*: Transmission/transaxle/CVT fluid, power steering fluid, brake fluid, etc.

UNIT DISASSEMBLY AND ASSEMBLY

ENGINE STAND SETTING

Setting

INFOID:000000003887374

NOTE:

Explained here is how to disassemble with engine stand supporting transmission surface. When using different type of engine stand, note with difference in steps and etc.

1. Remove the engine assembly from the vehicle. Refer to [EM-82, "2WD : Exploded View"](#) (2WD models) or [EM-87, "AWD : Exploded View"](#) (AWD models).

2. Remove crankshaft pulley. Refer to [EM-53, "Exploded View"](#).

NOTE:

The drive plate is fixed with a ring gear stopper [SST: KV10118600 (J-48641)]. Loosen the crankshaft pulley mounting bolts before installing the engine stand.

3. Remove the parts that may restrict installation of engine to a widely use engine stand.
 - Fix crankshaft with a ring gear stopper [SST: KV10118600 (J-48641)]. Loosen drive plate mounting bolt with power tool.
 - Check for deformation or damage of drive plate. Refer to [EM-117, "Exploded View"](#).

NOTE:

The procedure is described assuming that you use a widely use engine stand holding the surface, to which transmission is installed.

4. Remove pilot converter using the pilot bushing puller [SST: ST16610001 (J-23907)] (A), if necessary.

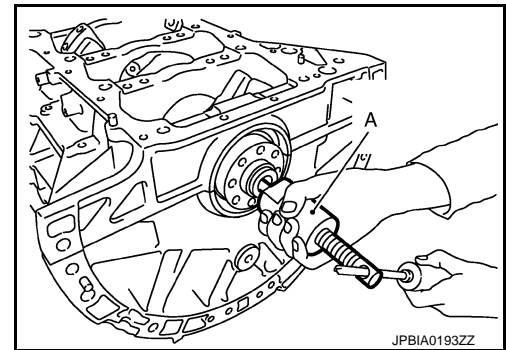

5. Lift the engine with hoist to install it onto the widely use engine stand.

CAUTION:

Use an engine stand that has a load capacity [220 kg (485 lb) or more] large enough for supporting the engine weight.

- If the load capacity of the stand is not adequate, remove the following parts beforehand to reduce the potential risk of overturning the stand.
 - Remove intake manifold collector. Refer to [EM-31, "Exploded View"](#).
 - Remove intake manifold. Refer to [EM-34, "Exploded View"](#).
 - Remove fuel injector and fuel tube assembly. Refer to [EM-40, "Exploded View"](#).
 - Remove ignition coil and rocker cover. Refer to [EM-50, "Exploded View"](#).
 - Remove exhaust manifold. Refer to [EM-36, "Exploded View"](#).
 - Other removable brackets.

NOTE:

The figure shows an example of widely use engine stand (A) that can hold mating surface of transmission with drive plate removed.

CAUTION:

Before removing the hanging chains, check the engine stand is stable and there is no risk of overturning.

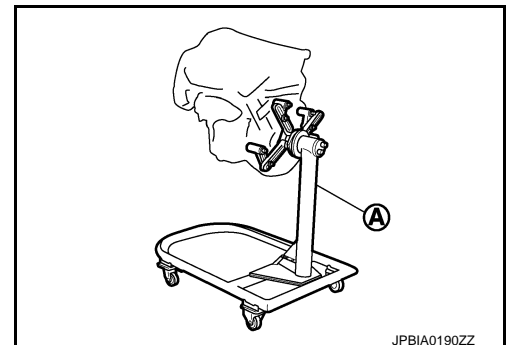

ENGINE STAND SETTING

[VQ35HR]

< UNIT DISASSEMBLY AND ASSEMBLY >

6. Drain engine oil. Refer to [LU-8, "Draining"](#).
7. Drain engine coolant by removing water drain plugs (1) and (4) from cylinder block both sides as shown in the figure.

- 2 : Washer
- 3 : Plug
- ⇐ : Engine front

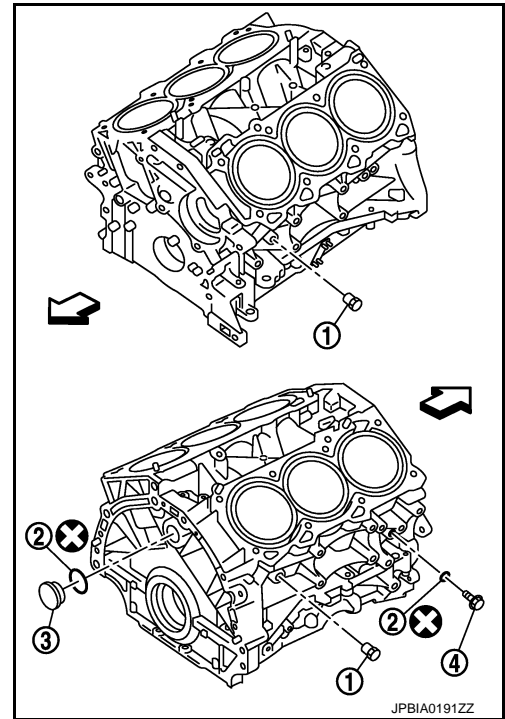

A

EM

C

D

E

F

G

H

I

J

K

L

M

N

O

P

ENGINE UNIT

Disassembly

INFOID:000000003887375

1. Remove intake manifold collector. Refer to [EM-31, "Exploded View"](#).
2. Remove intake manifold. Refer to [EM-34, "Exploded View"](#).
3. Remove exhaust manifold. Refer to [EM-36, "Exploded View"](#).
4. Remove oil pan (lower). Refer to [EM-46, "Exploded View"](#).
5. Remove ignition coil, spark plug and rocker cover. Refer to [EM-50, "Exploded View"](#).
6. Remove fuel injector and fuel tube. Refer to [EM-40, "Exploded View"](#).
7. Remove timing chain. Refer to [EM-53, "Exploded View"](#).
8. Remove rear timing chain case. Refer to [EM-95, "Exploded View"](#).
9. Remove camshaft. Refer to [EM-70, "Exploded View"](#).
10. Remove cylinder head. Refer to [EM-107, "Exploded View"](#).

Assembly

INFOID:000000003887376

Assembly in the reverse order of disassembly.

REAR TIMING CHAIN CASE

< UNIT DISASSEMBLY AND ASSEMBLY >

[VQ35HR]

REAR TIMING CHAIN CASE

Exploded View

INFOID:000000003887377

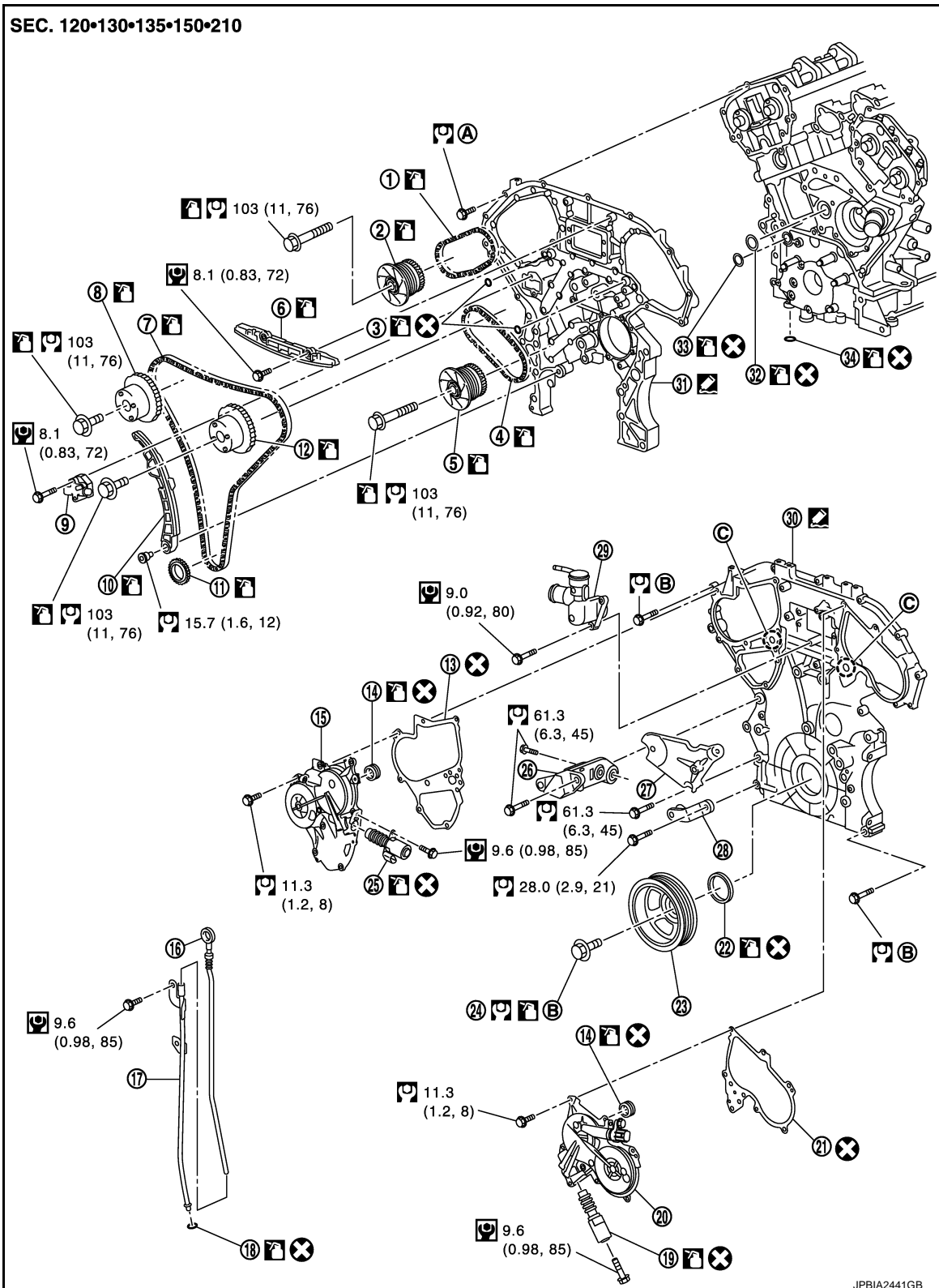

- | | | |
|-----------------------------|----------------------------|-------------------------------------|
| 1. Timing chain (secondary) | 2. Camshaft sprocket (EXH) | 3. O-ring |
| 4. Timing chain (secondary) | 5. Camshaft sprocket (EXH) | 6. Internal chain guide |
| 7. Timing chain (primary) | 8. Camshaft sprocket (INT) | 9. Timing chain tensioner (primary) |

A
C
D
E
F
G
H
I
J
K
L
M
N
O
P

EM

REAR TIMING CHAIN CASE

< UNIT DISASSEMBLY AND ASSEMBLY >

[VQ35HR]

- | | | |
|---|---|--|
| 10. Slack guide | 11. Crankshaft sprocket | 12. Camshaft sprocket (INT) |
| 13. Valve timing control cover gasket (bank 1) | 14. Seal ring | 15. Valve timing control cover (bank 1) |
| 16. Oil level gauge | 17. Oil level gauge guide | 18. O-ring |
| 19. Intake valve timing control solenoid valve (bank 2) | 20. Valve timing control cover (bank 2) | 21. Valve timing control cover gasket (bank 2) |
| 22. Front oil seal | 23. Crankshaft pulley | 24. Crankshaft pulley bolt |
| 25. Intake valve timing control solenoid valve (bank 1) | 26. Power steering oil pump bracket | 27. Idler pulley bracket |
| 28. Alternator bracket | 29. Water outlet (front) | 30. Front timing chain case |
| 31. Rear timing chain case | 32. O-ring | 33. O-ring |
| 34. O-ring | | |
| A. Refer to EM-97 | B. Refer to EM-54 | C. Oil filter |

Refer to [GI-4, "Components"](#) for symbols in the figure.

Disassembly

INFOID:000000003887378

1. Remove front timing chain case and timing chain. Refer to [EM-54, "Removal and Installation"](#).
2. Remove water pump. Refer to [CO-19, "Exploded View"](#).
3. Remove oil pan (upper). Refer to [EM-100, "2WD : Exploded View"](#) (2WD models) or [EM-103, "AWD : Exploded View"](#) (AWD models).
4. Remove rear timing chain case as per the following:
 - a. Loosen and remove mounting bolts in reverse order as shown in the figure.
 - b. Cut liquid gasket using the seal cutter [SST: KV10111100 (J-37228)] and remove rear timing chain case.

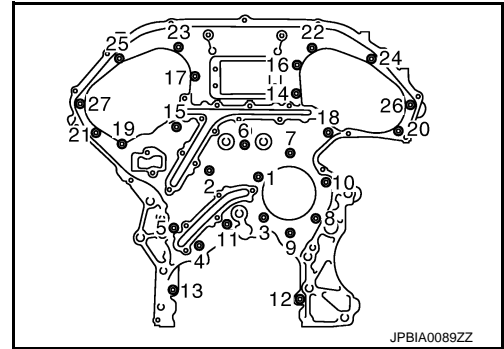

CAUTION:

- Never remove plate metal cover (1) of oil passage.
- After removal, handle rear timing chain case carefully so it does not tilt, cant, or warp under a load.

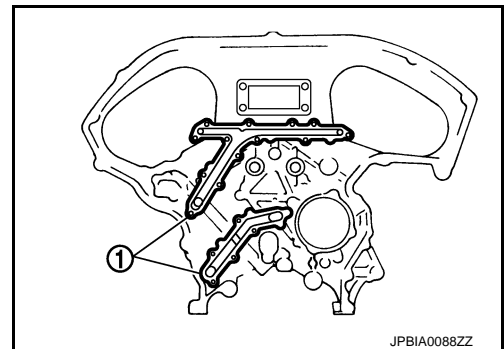

REAR TIMING CHAIN CASE

< UNIT DISASSEMBLY AND ASSEMBLY >

[VQ35HR]

5. Remove O-rings (1) from cylinder block.

⇐ : Engine front

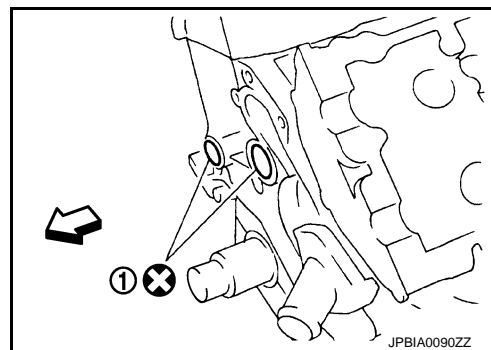

6. Remove timing chain tensioners (secondary) from cylinder head as per the following, if necessary.
 - a. Remove camshaft brackets (No. 1). Refer to [EM-70, "Exploded View"](#).
 - b. Remove timing chain tensioners (secondary) with a stopper pin (A) attached.

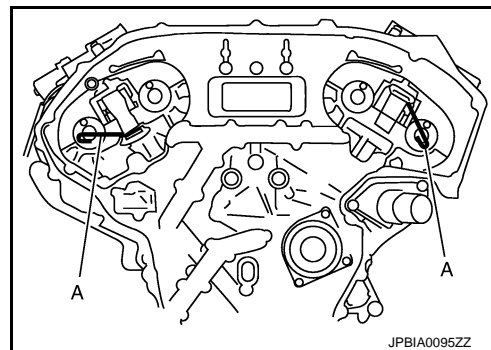

INFOID:000000003887379

Assembly

1. Install timing chain tensioners (secondary) to cylinder head as per the following, if removed. Refer to [EM-70, "Exploded View"](#).
 - a. Install timing chain tensioners (secondary) with a stopper pin attached and new O-rings.
 - b. Install camshaft brackets (No. 1). Refer to [EM-70, "Exploded View"](#).
 - c. Measure difference in levels between front end faces of camshaft bracket (No. 1) and cylinder head.

Standard : -0.14 to 0.14 mm (-0.0055 to 0.0055 in)

- Measure two positions (both intake and exhaust side) for a single bank.
- If the measured value is out of the standard, re-install camshaft bracket (No. 1).

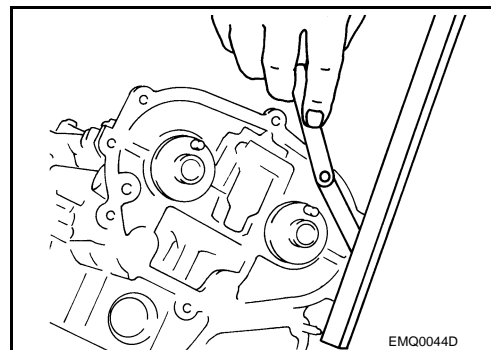

2. Install rear timing chain case as per the following:
 - a. Install new O-rings (1) onto cylinder block.

⇐ : Engine front

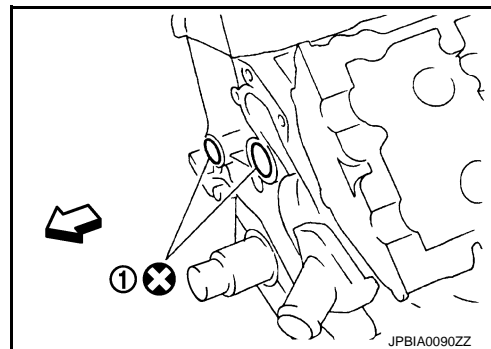

REAR TIMING CHAIN CASE

< UNIT DISASSEMBLY AND ASSEMBLY >

[VQ35HR]

- b. Apply liquid gasket with the tube presser (commercial service tool) to rear timing chain case back side as shown in the figure.
Use Genuine RTV Silicone Sealant or an equivalent. Refer to [GI-15, "Recommended Chemical Products and Sealants"](#).

CAUTION:

- For (A) in the figure, completely wipe out liquid gasket extended on a portion touching at engine coolant.
- Apply liquid gasket on installation position of water pump and cylinder head very completely.

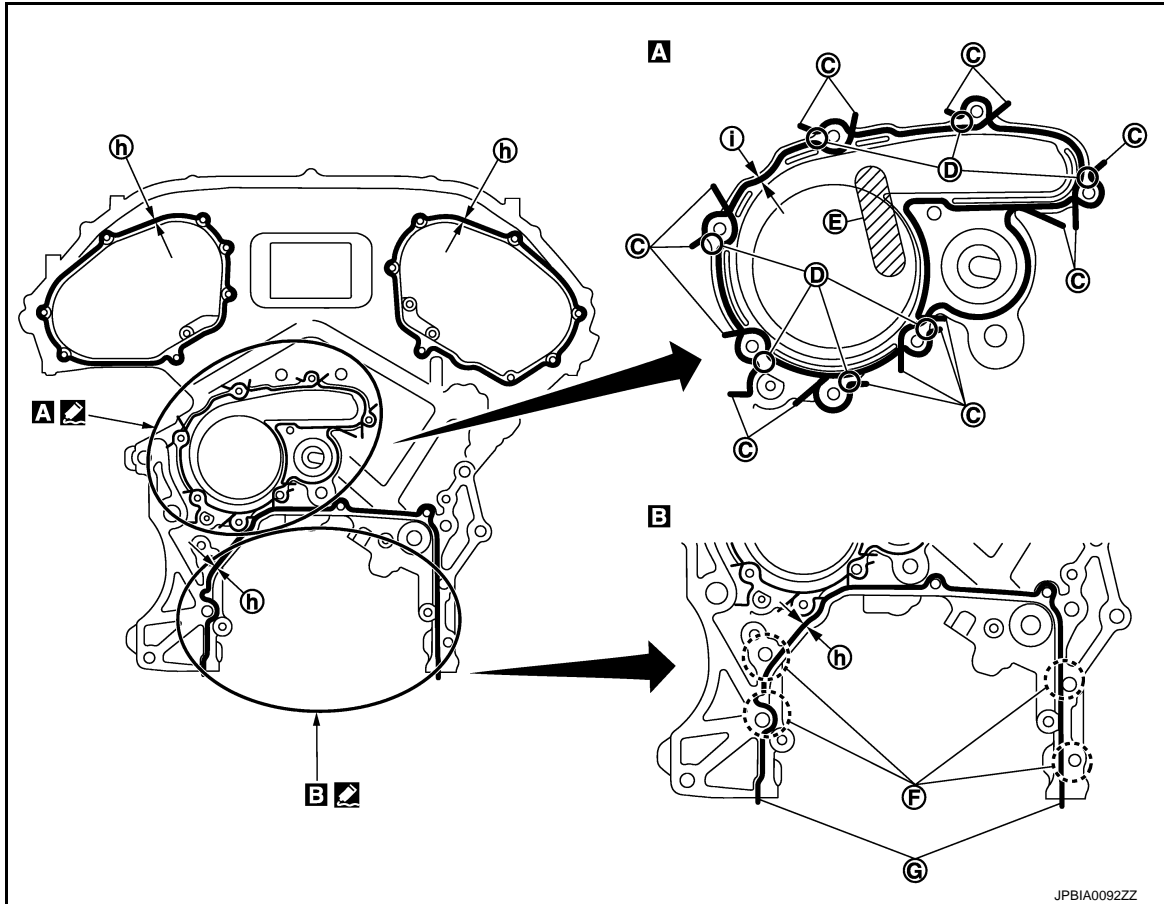

JPBIA0092ZZ

- | | | |
|-----------------------------------|---|---------------------------------|
| C. Protrusion | D. Clearance 1 mm (0.04 in) | E. Do not protrude in this area |
| F. Run along bolt hole inner side | G. Protrusions at beginning and end of gasket | |
| h. $\phi 3.9$ mm (0.154 in) | i. $\phi 2.7$ mm (0.106 in) | |

Refer to [GI-4, "Components"](#) for symbols in the figure.

- c. Align rear timing chain case with dowel pins (bank 1 and bank 2) on cylinder block and install rear timing chain case.
 • Check O-rings stay in place during installation to cylinder block and cylinder head.
- d. Tighten mounting bolts in numerical order as shown in the figure.
 • There are two types of mounting bolts. Refer to the following for locating bolts.

- | | |
|------------------------|----------------------------------|
| Bolt length: | Bolt position |
| 20 mm (0.79 in) | : 1, 2, 3, 6, 7, 8, 9, 10 |
| 16 mm (0.63 in) | : 4, 5, 11, 12, 13 |

: 12.7 N·m (1.3 kg·m, 9 ft·lb)

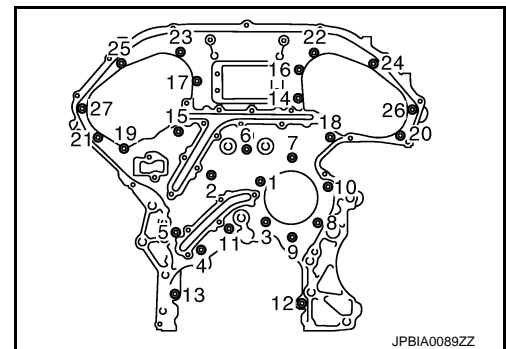

JPBIA0089ZZ

REAR TIMING CHAIN CASE

< UNIT DISASSEMBLY AND ASSEMBLY >

[VQ35HR]

Bolt length: 16 mm (0.63 in)
Bolt position : Except the above

 : 15.0 N·m (1.5 kg·m, 11 ft·lb)

- e. After all bolts are tightened, retighten them to the specified torque in numerical order shown in the figure.
 - If liquid gasket protrudes, wipe it off immediately.
- f. After installing rear timing chain case, check the surface height difference between the following parts on the oil pan (upper) mounting surface.

1 : Rear timing chain case
2 : Lower cylinder block

Standard

Rear timing chain case to lower cylinder block:
-0.24 to 0.14 mm (-0.0094 to 0.0055 in)

- If not within the standard, repeat the installation procedure.

3. Install water pump with new O-rings. Refer to [CO-19, "Exploded View"](#).
4. Check that dowel pin (A) and crankshaft key (1) are located as shown in the figure. (No. 1 cylinder at compression TDC)

NOTE:

Though camshaft does not stop at the position as shown in the figure, for the placement of cam nose, it is generally accepted camshaft is placed for the same direction of the figure.

Camshaft dowel pin

: At cylinder head upper face side in each bank.

Crankshaft key

: At cylinder head side of bank 1.

5. Install timing chains (secondary) and camshaft sprockets as per the following:

CAUTION:

Matching marks between timing chain and sprockets slip easily. Confirm all matching mark positions repeatedly during the installation process.

- a. Push plunger of timing chain tensioner (secondary) and keep it pressed in with a stopper pin (A).

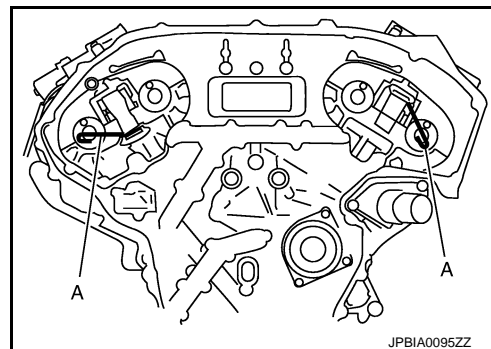
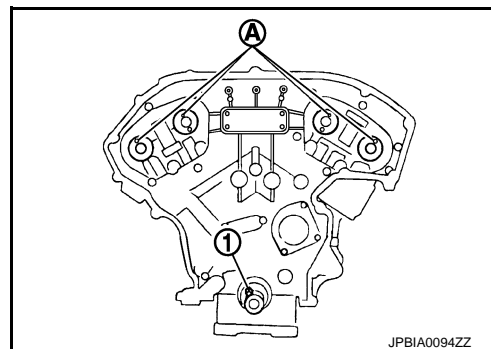
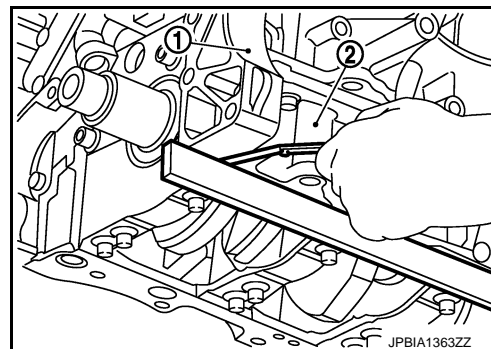

6. For the following operations, perform steps in the reverse order of removal.

OIL PAN (UPPER)

< UNIT DISASSEMBLY AND ASSEMBLY >

[VQ35HR]

OIL PAN (UPPER)

2WD

2WD : Exploded View

INFOID:000000003887380

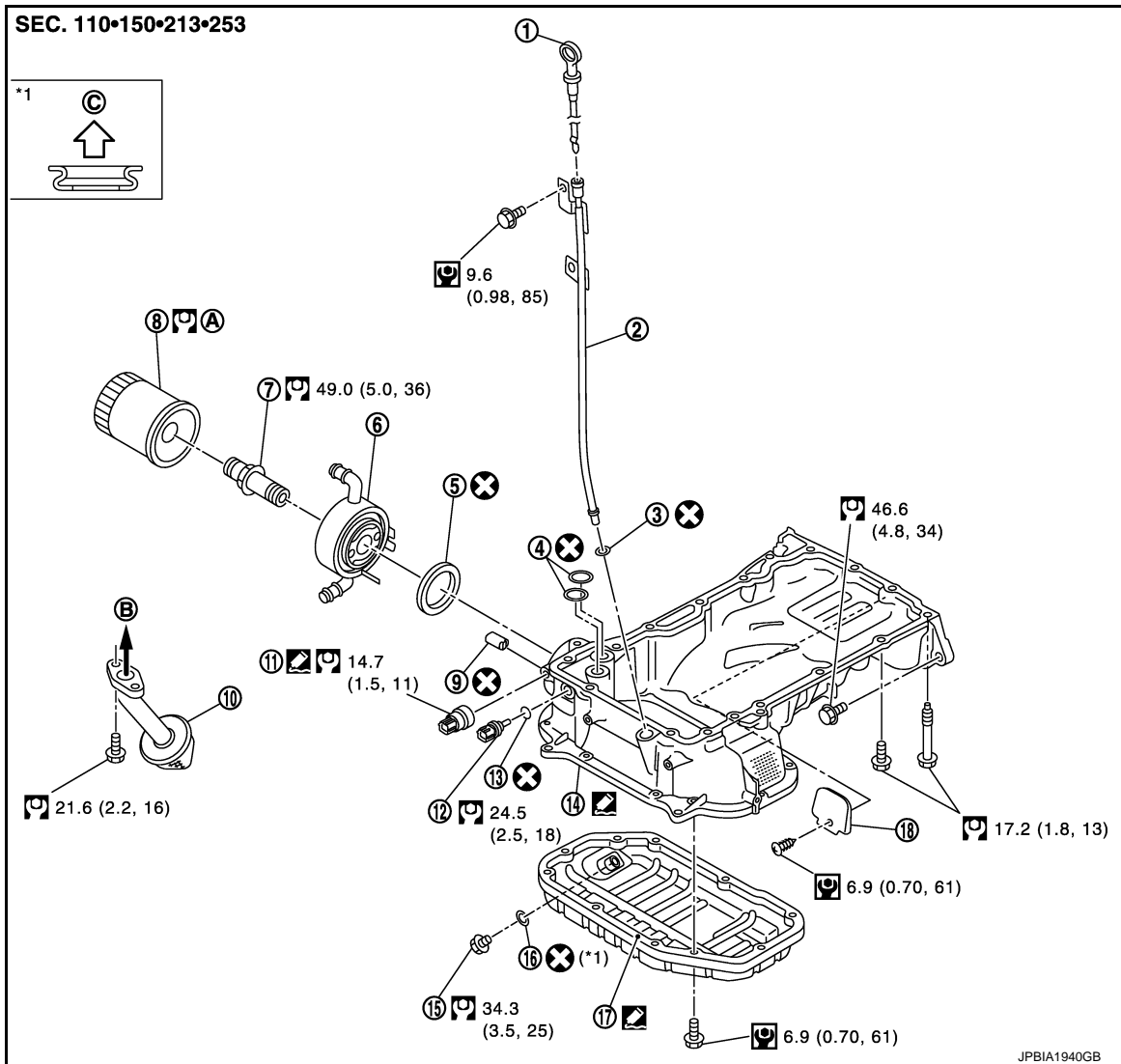

- | | | |
|----------------------------------|--------------------------|----------------------------|
| 1. Oil level gauge | 2. Oil level gauge guide | 3. O-ring |
| 4. O-ring | 5. O-ring | 6. Oil cooler |
| 7. Connector bolt | 8. Oil filter | 9. Relief valve |
| 10. Oil strainer | 11. Oil pressure switch | 12. Oil temperature sensor |
| 13. Washer | 14. Oil pan (upper) | 15. Drain plug |
| 16. Drain plug washer | 17. Oil pan (lower) | 18. Rear plate cover |
| A. Refer to LU-9 | B. To oil pump | C. Oil pan side |

Refer to [GI-4, "Components"](#) for symbols in the figure.

2WD : Disassembly and Assembly

INFOID:000000003887381

REMOVAL

CAUTION:

Never drain engine oil when the engine is hot to avoid the danger of being scalded.

1. Remove oil level gauge, oil pressure switch and oil temperature sensor.

OIL PAN (UPPER)

< UNIT DISASSEMBLY AND ASSEMBLY >

[VQ35HR]

2. Remove oil pan (lower). Refer to [EM-47. "Removal and Installation"](#).
3. Remove oil strainer.
4. Loosen mounting bolts in the reverse order as shown in the figure with power tool to remove.

← : Engine front

- Insert the seal cutter [SST: KV10111100 (J-37228)] between oil pan (upper) and lower cylinder block. Slide seal cutter by tapping on the side of tool with a hammer. Remove oil pan (upper).

CAUTION:

- Be careful not to damage the mating surfaces.
- Never insert a screwdriver, this will damage the mating surfaces.

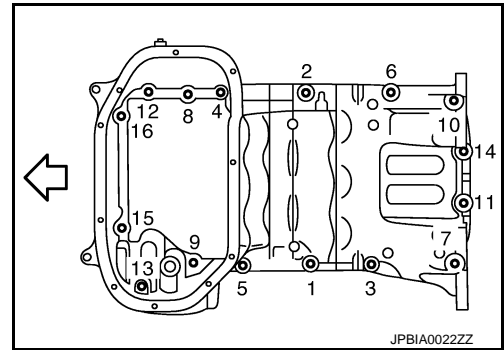

5. Remove O-rings (2) from bottom of lower cylinder block (1) and oil pump (3).

← : Engine front

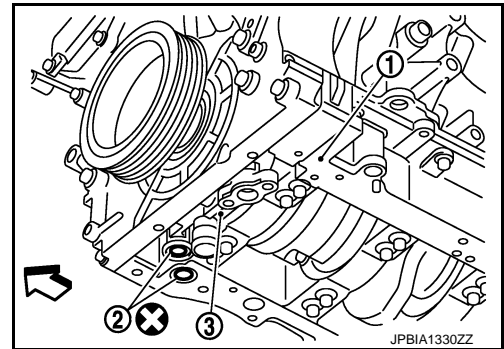

INSTALLATION

1. Install oil pan (upper) as per the following:
 - a. Use a scraper (A) to remove old liquid gasket from mating surfaces.

CAUTION:

Never scratch or damage the mating surfaces when cleaning off old liquid gasket.

- Also remove old liquid gasket from mating surface of lower cylinder block.
- Remove old liquid gasket from the bolt holes and threads.

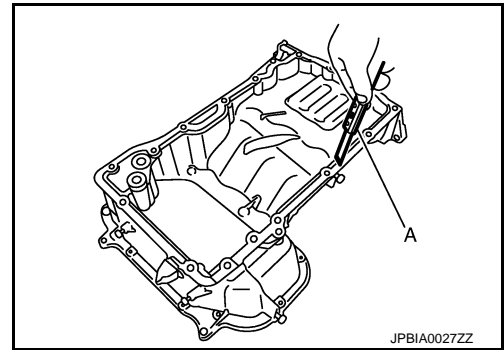

- b. Install new O-rings (2) on the bottom of lower cylinder block (1) and oil pump (3).

← : Engine front

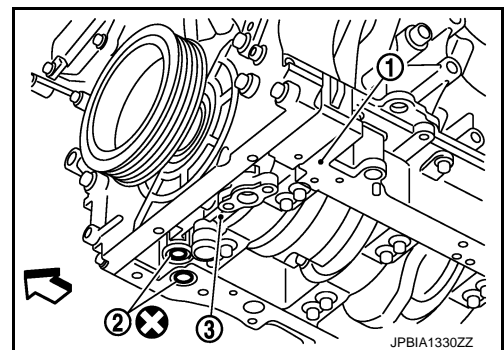

A
EM
C
D
E
F
G
H
I
J
K
L
M
N
O
P

OIL PAN (UPPER)

[VQ35HR]

< UNIT DISASSEMBLY AND ASSEMBLY >

- c. Apply a continuous bead of liquid gasket with the tube presser (commercial service tool) to the cylinder block mating surface of oil pan (upper) to a limited portion as shown in the figure.

a : $\phi 4.0 - 5.0$ mm (0.157 - 0.197 in)

↔ : Engine front

Use Genuine RTV Silicone Sealant or an equivalent. Refer to [GI-15, "Recommended Chemical Products and Sealants"](#).

CAUTION:

- For bolt holes with ▲ marks (7 locations), apply liquid gasket outside the holes.
- Attaching must be done within 5 minutes after coating.

- d. Install oil pan (upper).

CAUTION:

Install avoiding misalignment of both O-rings.

- Tighten mounting bolts in numerical order as shown in the figure.

↔ : Engine front

- There are two types of mounting bolts. Refer to the following for locating bolts.

M8 × 90 mm (3.54 in) : 7, 10, 13

M8 × 25 mm (0.98 in) : Except the above

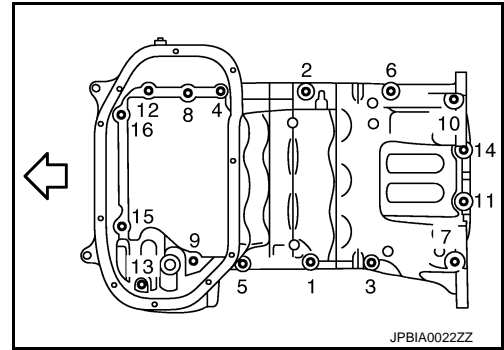
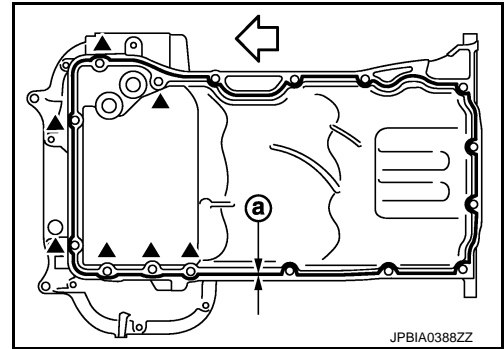

2. Install oil strainer to oil pump.
3. Install oil pan (lower). Refer to [EM-47, "Removal and Installation"](#).
4. Install oil pan drain plug.
 - Refer to the figure of components of former page for installation direction of drain plug washer. Refer to [EM-46, "Exploded View"](#).

5. Install in the reverse order of removal after this step.

NOTE:

At least 30 minutes after oil pan is installed, pour engine oil.

2WD : Inspection

INFOID:000000003887382

INSPECTION AFTER REMOVAL

Clean oil strainer if any object attached.

INSPECTION AFTER INSTALLATION

1. Check the engine oil level and adjust engine oil. Refer to [LU-6, "Inspection"](#).
2. Start engine, and check there is no leakage of engine oil.
3. Stop engine and wait for 10 minutes.
4. Check the engine oil level again. Refer to [LU-6, "Inspection"](#).

AWD

OIL PAN (UPPER)

< UNIT DISASSEMBLY AND ASSEMBLY >

[VQ35HR]

AWD : Exploded View

INFOID:000000003887383

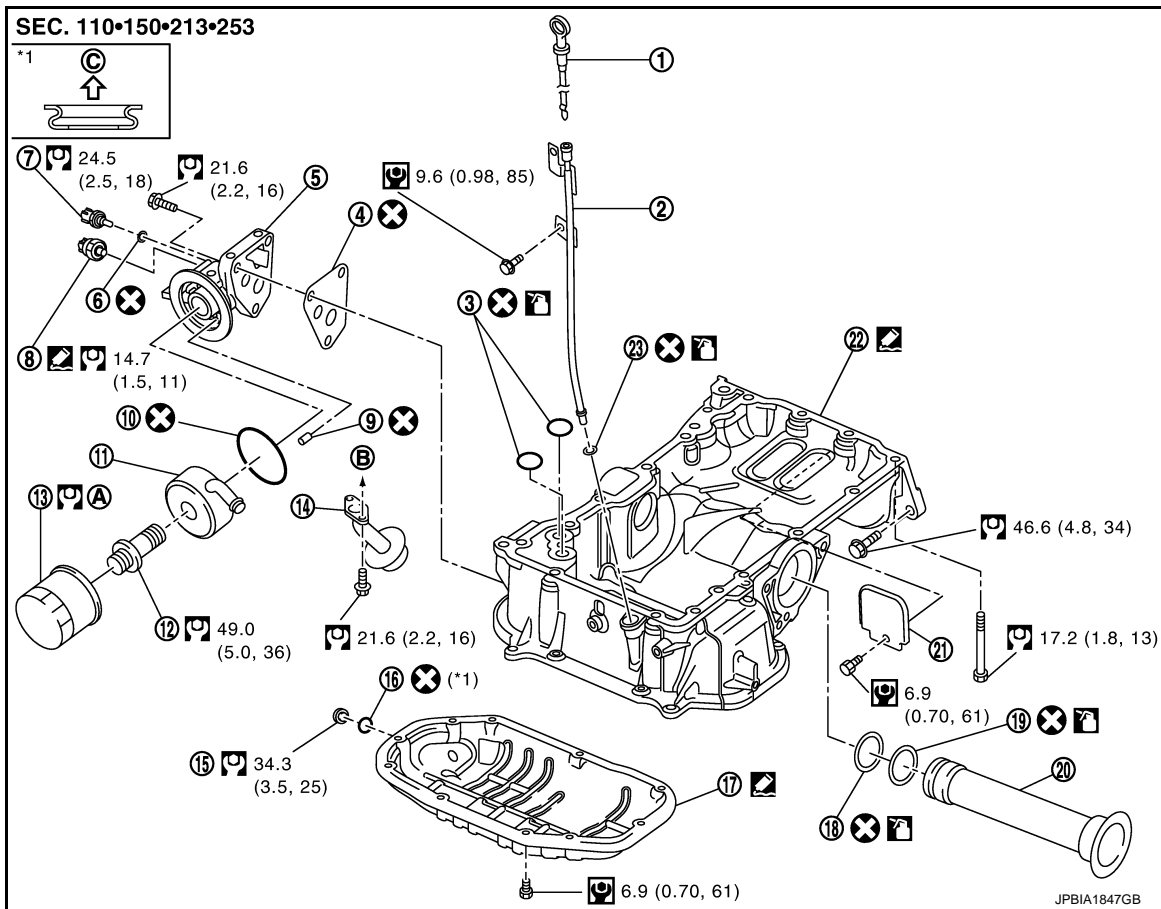

- | | | |
|---------------------------|--------------------------|----------------------|
| 1. Oil level gauge | 2. Oil level gauge guide | 3. O-ring |
| 4. Gasket | 5. Oil filter bracket | 6. Washer |
| 7. Oil temperature sensor | 8. Oil pressure sensor | 9. Relief valve |
| 10. O-ring | 11. Oil cooler | 12. Connector bolt |
| 13. Oil filter | 14. Oil strainer | 15. Drain plug |
| 16. Oil pan drain plug | 17. Oil pan (lower) | 18. O-ring (small) |
| 19. O-ring (large) | 20. Axle pipe | 21. Rear plate cover |
| 22. Oil pan (upper) | 23. O-ring | |
- A. Refer to [LU-9](#)
 B. To oil pump
 C. Oil pan side

Refer to [GI-4, "Components"](#) for symbols in the figure.

AWD : Disassembly and Assembly

INFOID:000000003887384

REMOVAL

CAUTION:

Never drain engine oil when the engine is hot to avoid the danger of being scalded.

1. Remove oil level gauge, oil pressure switch and oil temperature sensor.
2. Remove oil filter bracket. Refer to [LU-11, "Exploded View"](#).
3. Remove oil pan (lower). Refer to [EM-47, "Removal and Installation"](#).
4. Remove oil strainer.

OIL PAN (UPPER)

[VQ35HR]

< UNIT DISASSEMBLY AND ASSEMBLY >

5. Loosen mounting bolts in the reverse order as shown in the figure with power tool to remove.

⇐ : Engine front

- Insert the seal cutter [SST: KV10111100 (J-37228)] between oil pan (upper) and lower cylinder block. Slide seal cutter by tapping on the side of tool with a hammer. Remove oil pan (upper).

CAUTION:

- **Be careful not to damage the mating surfaces.**
- **Never insert a screwdriver, this will damage the mating surfaces.**

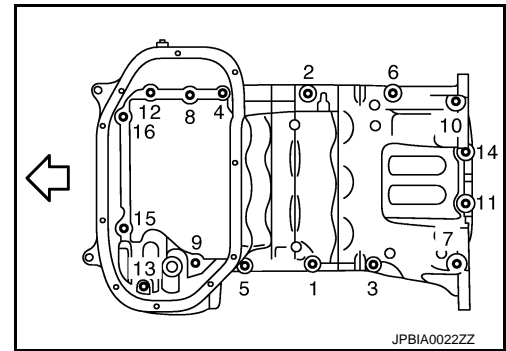

6. Remove O-rings (2) from bottom of lower cylinder block (1) and oil pump (3).

⇐ : Engine front

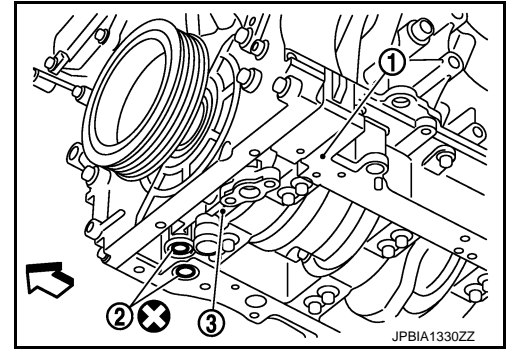

7. Remove axle pipe, if necessary.

- Remove axle pipe from oil pan (upper) using a suitable drift (A) [outer diameter: 37 mm (1.46 in)].

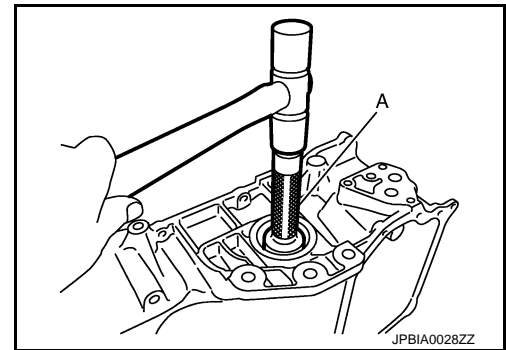

INSTALLATION

1. Install axle pipe (3) to oil pan (upper), if removed.
- Lubricate O-ring groove of axle pipe, O-rings (1), (2), and O-ring joint of oil pan with new engine oil.

Unit: mm (in)

Items	O-ring inner diameter
Final drive side (right side)	31.4 (1.236)
Axle pipe flange side (left side)	33.6 (1.323)

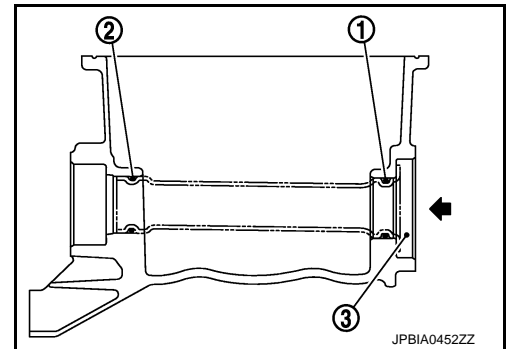

OIL PAN (UPPER)

< UNIT DISASSEMBLY AND ASSEMBLY >

[VQ35HR]

- Install axle pipe (1) to oil pan (upper) from axle pipe flange side (left side) using a suitable drift (A) [outer diameter: 43 to 57 mm (1.69 to 2.24 in)].

CAUTION:

Insert it with care to prevent O-ring from sliding.

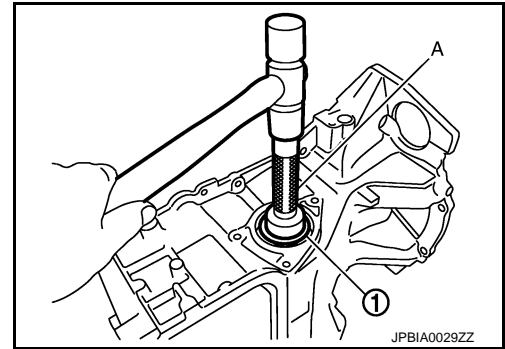

2. Install oil pan (upper) as per the following:

- a. Use a scraper (A) to remove old liquid gasket from mating surfaces.

CAUTION:

Never scratch or damage the mating surfaces when cleaning off old liquid gasket.

- Also remove old liquid gasket from mating surface of lower cylinder block.
- Remove old liquid gasket from the bolt holes and threads.

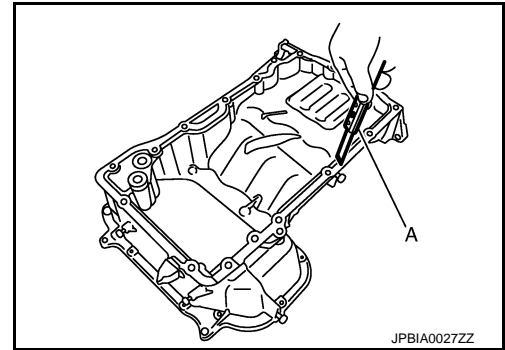

- b. Install new O-rings (2) on the bottom of lower cylinder block (1) and oil pump (3).

← : Engine front

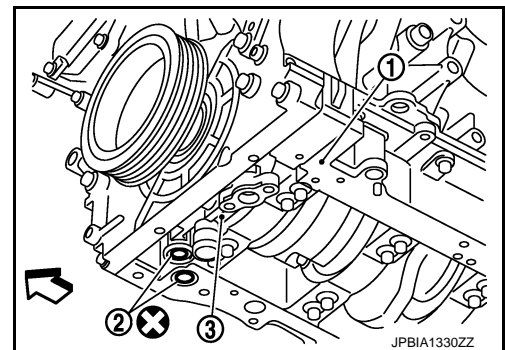

- c. Apply a continuous bead of liquid gasket with the tube presser (commercial service tool) to the cylinder block mating surface of oil pan (upper) to a limited portion as shown in the figure.

a : $\phi 4.0 - 5.0$ mm (0.157 - 0.197 in)

← : Engine front

Use Genuine RTV Silicone Sealant or an equivalent. Refer to [GI-15, "Recommended Chemical Products and Sealants"](#).

CAUTION:

- For bolt holes with ▲ marks (7 locations), apply liquid gasket outside the holes.
- Attaching must be done within 5 minutes after coating.

- d. Install oil pan (upper).

CAUTION:

Install avoiding misalignment of O-rings.

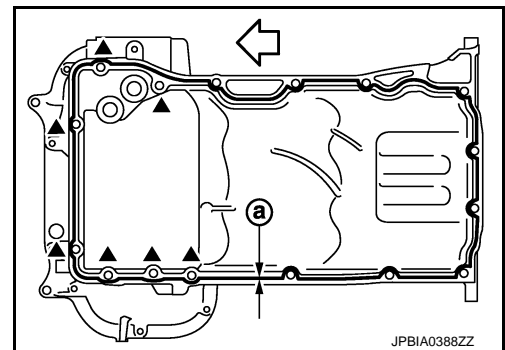

OIL PAN (UPPER)

[VQ35HR]

< UNIT DISASSEMBLY AND ASSEMBLY >

- Tighten mounting bolts in numerical order as shown in the figure.

⇐ : Engine front

- There are three types of mounting bolts. Refer to the following for locating bolts.

M8 × 25 mm (0.98 in) : 3, 6, 8, 9, 11, 12, 14, 15, 16

M8 × 50 mm (1.97 in) : 2

M8 × 90 mm (3.54 in) : 1, 4, 5, 7, 10, 13

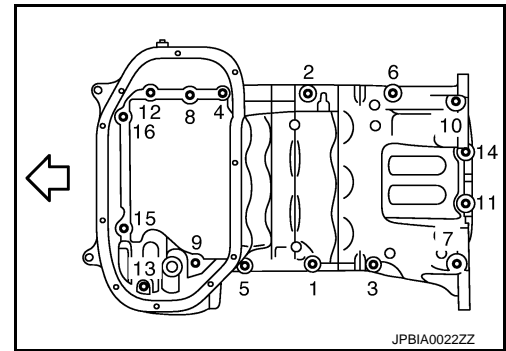

3. Install oil strainer to oil pump.
4. Install oil pan (lower). Refer to [EM-47. "Removal and Installation"](#).
5. Install oil pan drain plug.
 - Refer to the figure of components of former page for installation direction of drain plug washer. Refer to [EM-103. "AWD : Exploded View"](#).
6. Install in the reverse order of removal after this step.

NOTE:

At least 30 minutes after oil pan is installed, pour engine oil.

AWD : Inspection

INFOID:000000003887385

INSPECTION AFTER REMOVAL

Clean oil strainer if any object attached.

INSPECTION AFTER INSTALLATION

1. Check the engine oil level and adjust engine oil. Refer to [LU-6. "Inspection"](#).
2. Start engine, and check there is no leakage of engine oil.
3. Stop engine and wait for 10 minutes.
4. Check the engine oil level again. Refer to [LU-6. "Inspection"](#).

CYLINDER HEAD

< UNIT DISASSEMBLY AND ASSEMBLY >

[VQ35HR]

CYLINDER HEAD

Exploded View

INFOID:000000003887386

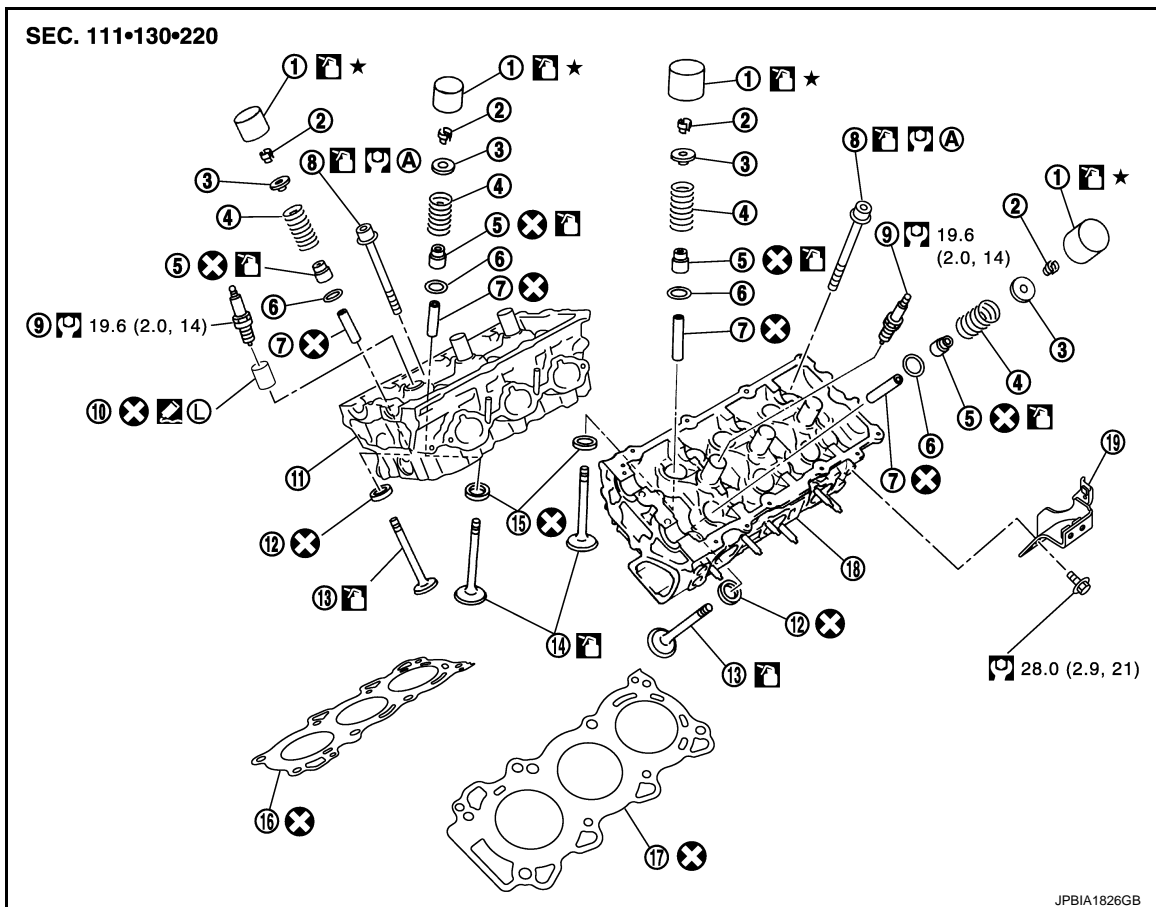

- | | | |
|-----------------------------------|-----------------------------------|----------------------------|
| 1. Valve lifter | 2. Valve collet | 3. Valve spring retainer |
| 4. Valve spring | 5. Valve oil seal | 6. Valve spring seat |
| 7. Valve guide | 8. Cylinder head bolt | 9. Spark plug |
| 10. Spark plug tube | 11. Cylinder head (bank 1) | 12. Valve seat (EXH) |
| 13. Valve (EXH) | 14. Valve (INT) | 15. Valve seat (INT) |
| 16. Cylinder head gasket (bank 1) | 17. Cylinder head gasket (bank 2) | 18. Cylinder head (bank 2) |
| 19. Engine rear lower slinger | | |

A. Refer to [EM-107](#)

Apply high strength thread locking sealant or equivalent.

Refer to [GI-4, "Components"](#) for symbols not described on the above.

Disassembly and Assembly

INFOID:000000003887387

DISASSEMBLY

- Remove the following parts:
 - Intake manifold collector: Refer to [EM-31, "Exploded View"](#).
 - Rocker cover and spark plug: Refer to [EM-50, "Exploded View"](#).
 - Fuel tube and fuel injector assembly: Refer to [EM-40, "Exploded View"](#).
 - Intake manifold: Refer to [EM-34, "Exploded View"](#).
 - Exhaust manifold: Refer to [EM-36, "Exploded View"](#).
 - Water inlet and thermostat assembly: Refer to [CO-22, "Exploded View"](#).
 - Water outlets (front and rear), water pipe and heater pipe: Refer to [CO-24, "Exploded View"](#).
 - Timing chain: Refer to [EM-53, "Exploded View"](#).

CYLINDER HEAD

< UNIT DISASSEMBLY AND ASSEMBLY >

[VQ35HR]

- Rear timing chain case: Refer to [EM-95, "Exploded View"](#).
 - Camshaft: Refer to [EM-70, "Exploded View"](#).
2. Remove cylinder head.
- Loosen cylinder head bolts in reverse order as shown in the figure with cylinder head bolt wrench (commercial service tool) and power tool.

A : Bank 1

B : Bank 2

⇐ : Engine front

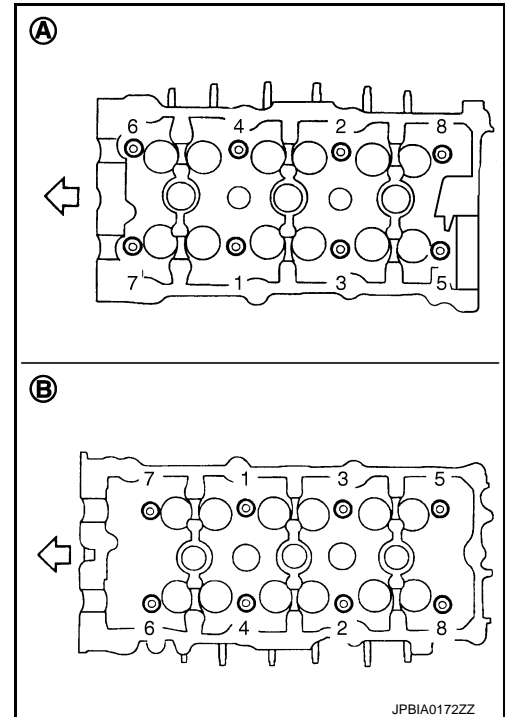

3. Remove cylinder head gaskets.
4. Remove valve lifter.
- Identify installation positions, and store them without mixing them up.
5. Remove valve collet.
- Compress valve spring with the valve spring compressor [SST: KV10116200 (J-26336-A)] (A), the attachment [SST: KV10115900 (J-26336-20)] (C) and the adapter [SST: KV10109220 (—)] (B). Remove valve collet with a magnet hand.

CAUTION:

When working, take care not to damage valve lifter holes.

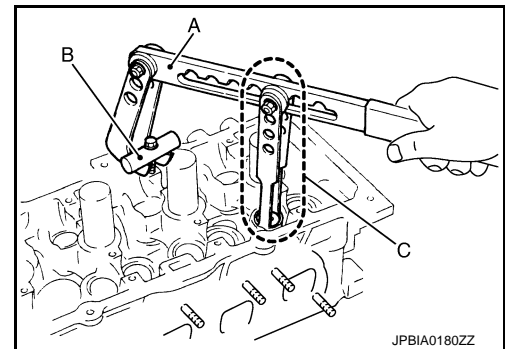

6. Remove valve spring retainer, valve spring and valve spring seat.
7. Push valve stem to combustion chamber side, and remove valve.
- Identify installation positions, and store them without mixing them up.
8. Remove valve oil seal using the valve oil seal puller [SST: KV10107902 (J-38959)] (A).

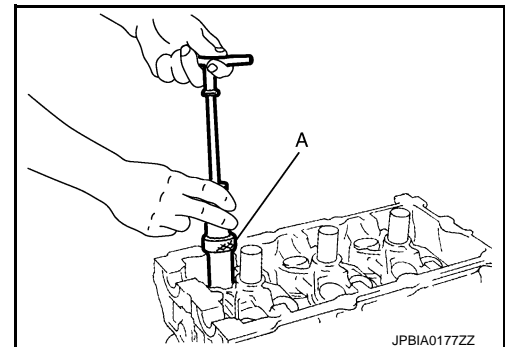

9. Remove valve seat, if valve seat must be replaced.

CYLINDER HEAD

< UNIT DISASSEMBLY AND ASSEMBLY >

[VQ35HR]

- Bore out old seat until it collapses. Boring should not continue beyond the bottom face of the seat recess in cylinder head. Set the machine depth stop to ensure this. Refer to [EM-145, "Cylinder Head"](#).

CAUTION:

Prevent to scratch cylinder head by excessive boring.

10. Remove valve guide, if valve guide must be replaced.
 - a. To remove valve guide, heat cylinder head to 110 to 130°C (230 to 266°F) by soaking in heated oil (A).

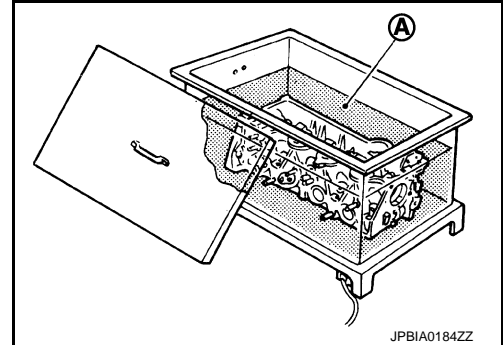

- b. Drive out valve guide with a press [under a 20 kN (2 ton, 2.2 US ton, 2.0 Imp ton) pressure] or a hammer and the valve guide drift (commercial service tool).

WARNING:

Cylinder head contains heat. When working, wear protective equipment to avoid getting burned.

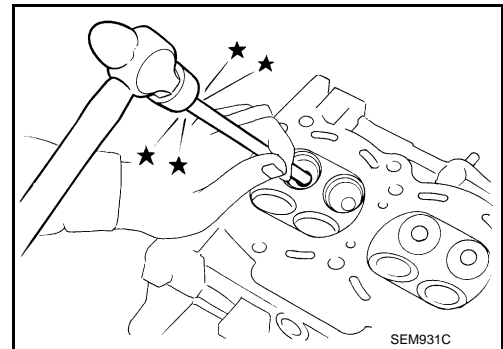

11. Remove spark plug tube, if necessary.
 - Using a pliers, pull spark plug tube out of cylinder head.

CAUTION:

- **Take care not to damage cylinder head.**
- **Once removed, spark plug tube will be deformed and cannot be reused. Never remove it unless absolutely necessary.**

ASSEMBLY

1. If valve guide is removed in step 10 (DISASSEMBLY), install it.
 - Replace with oversized [0.2 mm (0.008 in)] valve guide.
 - a. Using the valve guide reamer (commercial service tool) (A), ream cylinder head valve guide hole.

Valve guide hole diameter (for service parts):

Intake and exhaust

: Refer to [EM-145, "Cylinder Head"](#).

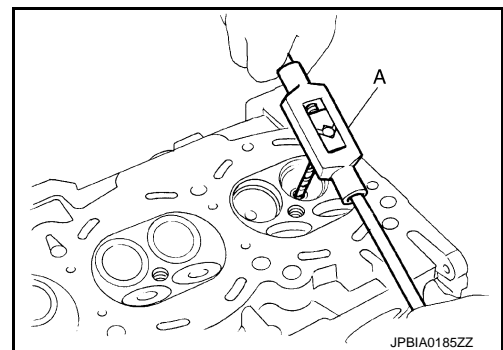

CYLINDER HEAD

[VQ35HR]

< UNIT DISASSEMBLY AND ASSEMBLY >

- b. Heat cylinder head to 110 to 130°C (230 to 266°F) by soaking in heated oil (A).

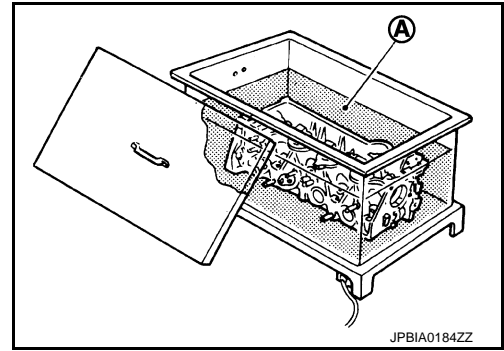

- c. Using the valve guide drift (commercial service tool), press valve guide from camshaft side to the dimensions as shown in the figure.

Projection (A)

Intake and exhaust

: Refer to [EM-145, "Cylinder Head"](#).

WARNING:

Cylinder head contains heat. When working, wear protective equipment to avoid getting burned.

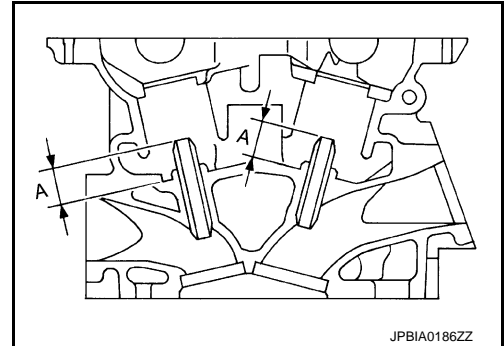

- d. Using the valve guide reamer (commercial service tool) (A), apply reamer finish to valve guide.

Standard

: Refer to [EM-145,](#)

(Intake and exhaust)

["Cylinder Head"](#).

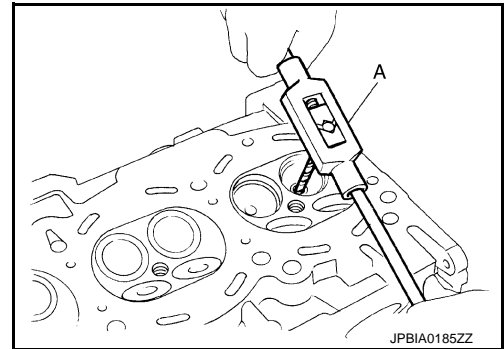

2. If valve seat is removed in step 9 (DISASSEMBLY), install it. Replace with oversize [0.5 mm (0.020 in)] valve seat.

- a. Ream cylinder head recess diameter (a) for service valve seat.

Oversize

: Refer to [EM-145,](#)

(Intake and exhaust)

["Cylinder Head"](#).

- Be sure to ream in circles concentric to valve guide center. This enables valve to fit correctly.

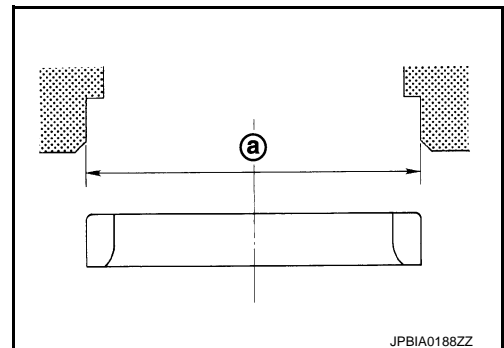

CYLINDER HEAD

< UNIT DISASSEMBLY AND ASSEMBLY >

[VQ35HR]

- b. Heat cylinder head to 110 to 130°C (230 to 266°F) by soaking in heated oil (A).

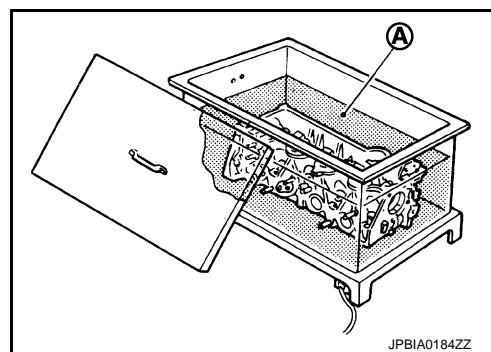

- c. Provide valve seats cooled well with dry ice. Force fit valve seat into cylinder head.

WARNING:

Cylinder head contains heat. When working, wear protective equipment to avoid getting burned.

CAUTION:

Never directly touching cold valve seats.

- d. Using the valve seat cutter set (commercial service tool) or valve seat grinder, finish seat to the specified dimensions. Refer to [EM-145, "Cylinder Head"](#).

CAUTION:

When using the valve seat cutter, firmly grip cutter handle with both hands. Then, press on the contacting surface all around the circumference to cut in a single drive. Improper pressure on with cutter or cutting many different times may result in stage valve seat.

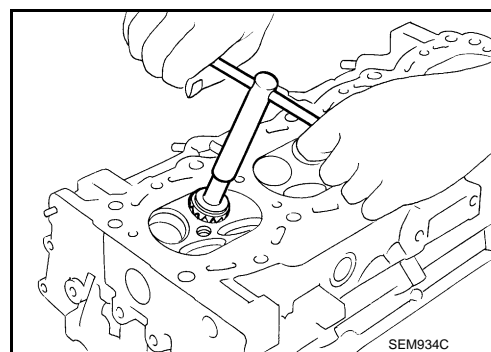

- e. Using compound, grind to adjust valve fitting.

- f. Check again for normal contact. Refer to [EM-107, "Disassembly and Assembly"](#).

3. Install new valve oil seals as per the following:

- a. Apply new engine oil on valve oil seal joint and seal lip.

- b. Install with the valve oil seal drift [SST: KV10115600 (J-38958)] (A) to match dimension in the figure.

Height (b) (Without valve spring seat installed)

Intake and exhaust : 14.3 - 14.9 mm (0.563 - 0.587 in)

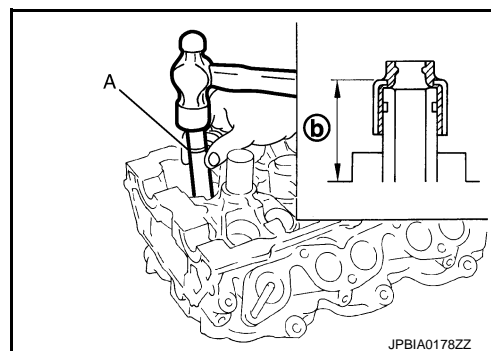

4. Install valve spring seat.

5. Install valve.

NOTE:

Larger diameter valves are for intake side.

6. Install valve spring (uneven pitch type).

CYLINDER HEAD

< UNIT DISASSEMBLY AND ASSEMBLY >

[VQ35HR]

- Install narrow pitch end to cylinder head side (valve spring seat side).

- A : Wide pitch
- B : Narrow pitch
- C : Paint mark
- ⇐ : Cylinder head side

Paint mark color : Yellowish green

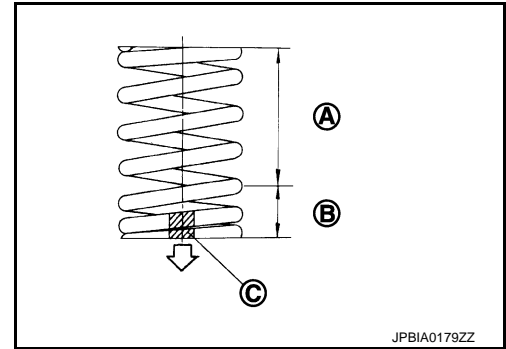

JPBIA0179ZZ

7. Install valve spring retainer.
8. Install valve collet.

- Compress valve spring with the valve spring compressor [SST: KV10116200 (J-26336-A)] (A), the attachment [SST: KV10115900 (J-26336-20)] (C) and the adapter [SST: KV10116200 (—)] (B). Install valve collet with a magnet hand.

CAUTION:

When working, take care not to damage valve lifter holes.

- Tap valve stem edge lightly with plastic hammer after installation to check its installed condition.

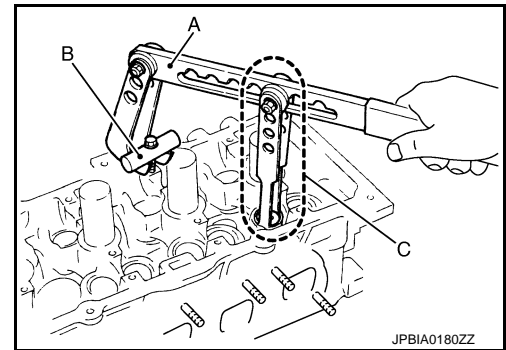

JPBIA0180ZZ

9. Install spark plug tube.

- Press-fit spark plug tube as per the following:

- Remove old locking sealant adhering to cylinder head mounting hole.
- Apply sealant to area within approximately 12 mm (0.47 in) from edge of spark plug tube press-fit side. **Use Genuine high strength thread locking sealant or an equivalent. Refer to [GI-15, "Recommended Chemical Products and Sealants"](#).**
- Using drift, press-fit spark plug tube so that its height (A) is as specified in the figure.

- B : High strength thread locking sealant application area

Standard press-fit height:

: 37.7 - 38.7 mm (1.484 - 1.524 in)

CAUTION:

- When press-fitting, take care not to deform spark plug tube.
- After press-fitting, wipe out liquid gasket protruding onto cylinder-head upper face.

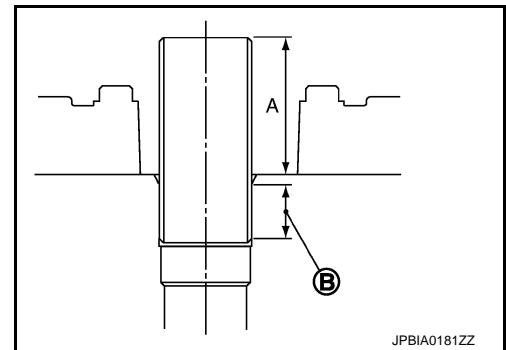

JPBIA0181ZZ

10. Install new cylinder head gaskets.
11. Turn crankshaft until No. 1 piston is set at TDC.

- 1 : Crankshaft key
- ⇐ : Bank 1 side

- Crankshaft key should line up with the bank 1 cylinder center line as shown in the figure.

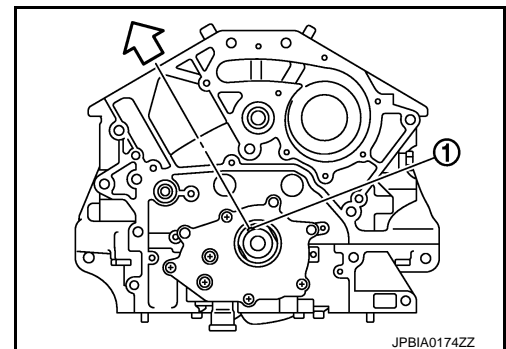

JPBIA0174ZZ

CYLINDER HEAD

< UNIT DISASSEMBLY AND ASSEMBLY >

[VQ35HR]

12. Install cylinder head follow the steps below to tighten cylinder head bolts in numerical order as shown in the figure with cylinder head bolts wrench (commercial service tool).

- A : Bank 1
- B : Bank 2
- ↔ : Engine front

CAUTION:

- If cylinder head bolts re-used, check their outer diameters before installation. Refer to **EM-114, "Inspection"**.
- Before installing cylinder head, inspect cylinder head distortion. Refer to **EM-114, "Inspection"**.

- a. Apply new engine oil to threads and seat surfaces of cylinder head bolts.
- b. Tighten all cylinder head bolts.

: 105 N·m (11 kg·m, 77 ft·lb)

- c. Completely loosen all cylinder head bolts.

: 0 N·m (0 kg·m, 0 ft·lb)

CAUTION:

In step "c", loosen bolts in reverse order of that indicated in the figure.

- d. Tighten all cylinder head bolts.

: 40.0 N·m (4.1 kg·m, 30 ft·lb)

- e. Tighten all cylinder head bolts (clockwise).

Angle tightening: 95 degrees

CAUTION:

Check the tightening angle by using the angle wrench [SST: KV10112100 (BT8653-A)] (A). Never make judgment by visual inspection.

- Check tightening angle indicated on the angle wrench indicator plate.

- f. Tighten all cylinder head bolts again (clockwise).

Angle tightening: 95 degrees

13. After installing cylinder head, measure distance between front end faces of cylinder block and cylinder head (bank 1 and bank 2).

Standard : 14.1 - 14.9 mm (0.555 - 0.587 in)

- If measured value is out of the standard, reinstall cylinder head.

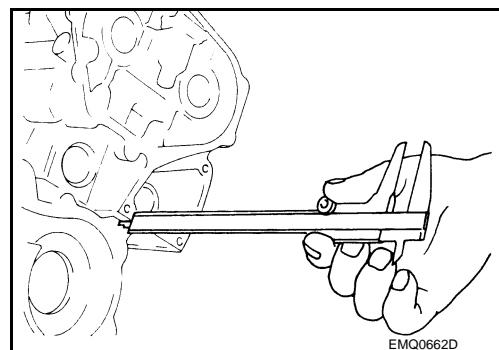
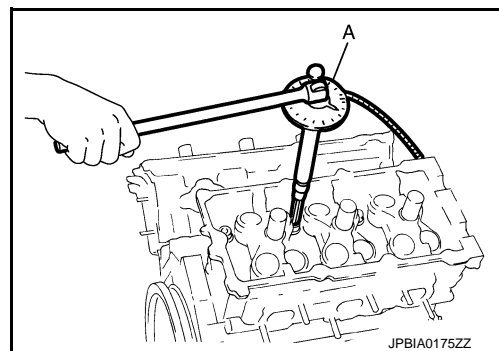
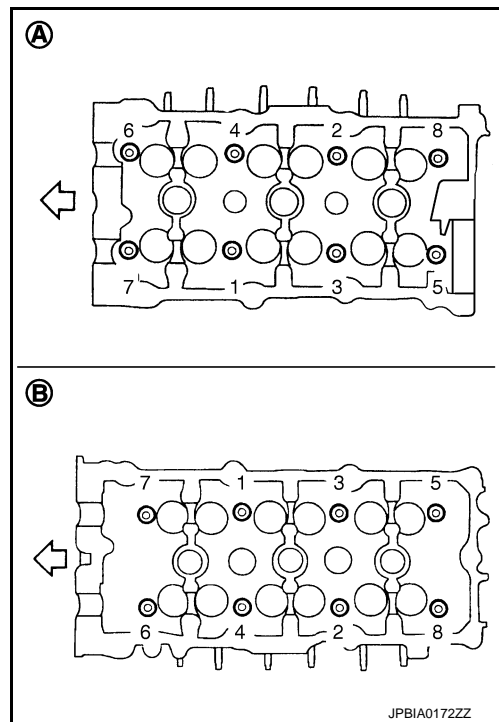

14. Install valve lifter.
 - Install it in the original position.

CYLINDER HEAD

< UNIT DISASSEMBLY AND ASSEMBLY >

[VQ35HR]

15. Install spark plug with spark plug wrench (commercial service tool).
16. Install in the reverse order of removal after this step.

Inspection

INFOID:000000003887388

INSPECTION AFTER REMOVAL

Cylinder Head Bolts Outer Diameter

- Cylinder head bolts are tightened by plastic zone tightening method. Whenever the size difference between (C) and (B) exceeds the limit, replace them with new one.

Limit [(C) - (B)] : 0.18 mm (0.0071 in)

- A : Measuring point
- e : 48 mm (1.89 in)
- d : 11 mm (0.43 in)

- If reduction of outer diameter appears in a position other than (B), use it as (B) point.

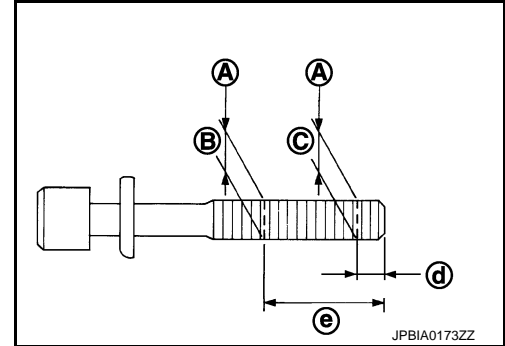

Cylinder Head Distortion

NOTE:

When performing this inspection, cylinder block distortion should be also checking. Refer to [EM-114, "Inspection"](#).

1. Using a scraper, wipe out oil, scale, gasket, sealant and carbon deposits from surface of cylinder head.

CAUTION:

Never allow gasket fragments to enter engine oil or engine coolant passages.

2. At each of several locations on bottom surface of cylinder head, measure the distortion in six directions (A, B, C, D, E, and F).

Limit : Refer to [EM-145, "Cylinder Head"](#).

- If it exceeds the limit, replace cylinder head.

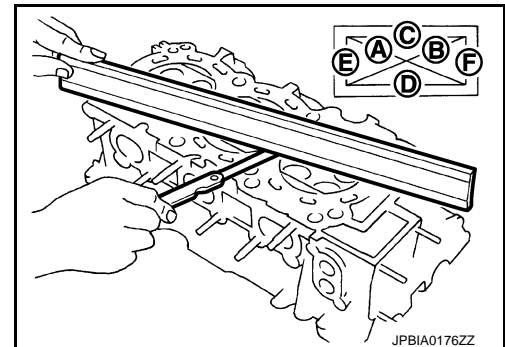

INSPECTION AFTER DISASSEMBLY

Valve Dimensions

- Check the dimensions of each valve. For the dimensions, refer to [EM-145, "Cylinder Head"](#).
- If dimensions are out of the standard, replace valve and check valve seat contact. Refer to "VALVE SEAT CONTACT".

Valve Guide Clearance

Valve Stem Diameter

- Measure the diameter of valve stem with micrometer (A).

Standard (Intake and exhaust) : Refer to [EM-145, "Cylinder Head"](#).

Valve Guide Inner Diameter

- Measure the inner diameter of valve guide with bore gauge.

Standard (Intake and exhaust) : Refer to [EM-145, "Cylinder Head"](#).

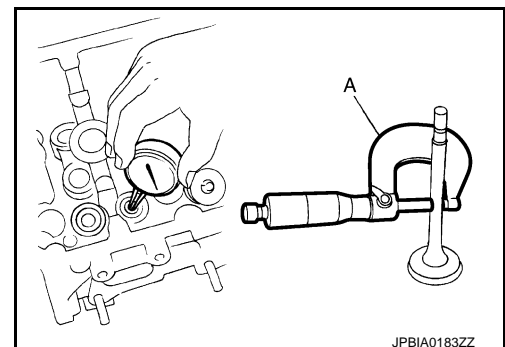

CYLINDER HEAD

< UNIT DISASSEMBLY AND ASSEMBLY >

[VQ35HR]

Valve Guide Clearance

- (Valve guide clearance) = (Valve guide inner diameter) – (Valve stem diameter)

Valve guide clearance

Standard and limit (Intake and exhaust) : Refer to [EM-145, "Cylinder Head"](#).

- If the calculated value exceeds the limit, replace valve and/or valve guide. When valve guide must be replaced, refer to [EM-107, "Disassembly and Assembly"](#).

Valve Seat Contact

- After confirming that the dimensions of valve guides and valves are within the specifications, perform this procedure.
- Apply prussian blue (or white lead) onto contacting surface of valve seat to check the condition of the valve contact on the surface.
- Check if the contact area band is continuous all around the circumference.
- If not, grind to adjust valve fitting and check again. If the contacting surface still has "NG" (B) conditions even after the recheck, replace valve seat. Refer to [EM-107, "Disassembly and Assembly"](#).

A : OK

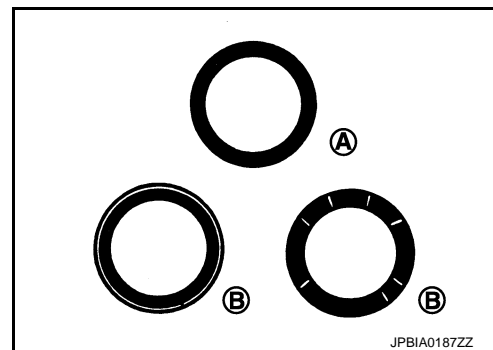

Valve Spring Squareness

- Set a try square (A) along the side of valve spring and rotate spring. Measure the maximum clearance between the top of spring and try square.

B : Contact

Limit : Refer to [EM-145, "Cylinder Head"](#).

- If it exceeds the limit, replace valve spring.

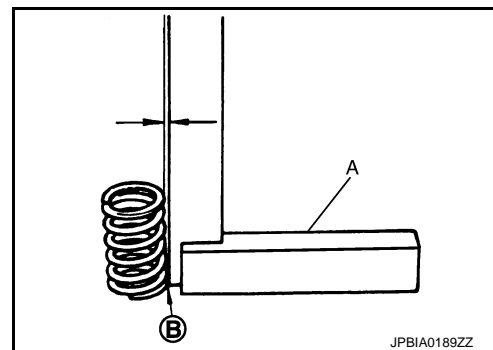

Valve Spring Dimensions and Valve Spring Pressure Load

- Check the valve spring pressure at specified spring height.

Standard (Intake and exhaust)

Free height

Installation height

Installation load

Height during valve open

Load with valve open

: Refer to [EM-145, "Cylinder Head"](#).

- If the installation load or load with valve open is out of the standard, replace valve spring.

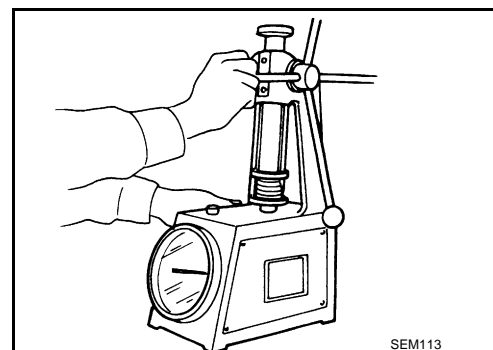

INSPECTION AFTER INSTALLATION

Inspection for Leakage

The following are procedures for checking fluids leakage, lubricates leakage and exhaust gases leakage.

- Before starting engine, check oil/fluid levels including engine coolant and engine oil. If less than required quantity, fill to the specified level. Refer to [MA-12, "Fluids and Lubricants"](#).
- Use procedure below to check for fuel leakage.

CYLINDER HEAD

< UNIT DISASSEMBLY AND ASSEMBLY >

[VQ35HR]

- Turn ignition switch "ON" (with engine stopped). With fuel pressure applied to fuel piping, check for fuel leakage at connection points.
- Start engine. With engine speed increased, check again for fuel leakage at connection points.
- Run engine to check for unusual noise and vibration.
- Warm up engine thoroughly to check there is no leakage of fuel, exhaust gases, or any oil/fluids including engine oil and engine coolant.
- Bleed air from lines and hoses of applicable lines, such as in cooling system.
- After cooling down engine, again check oil/fluid levels including engine oil and engine coolant. Refill to the specified level, if necessary.

Summary of the inspection items:

Items	Before starting engine	Engine running	After engine stopped
Engine coolant	Level	Leakage	Level
Engine oil	Level	Leakage	Level
Other oils and fluid*	Level	Leakage	Level
Fuel	Leakage	Leakage	Leakage
Exhaust gases	—	Leakage	—

*: Transmission/transaxle/CVT fluid, power steering fluid, brake fluid, etc.

CYLINDER BLOCK

< UNIT DISASSEMBLY AND ASSEMBLY >

[VQ35HR]

CYLINDER BLOCK

Exploded View

INFOID:000000003887389

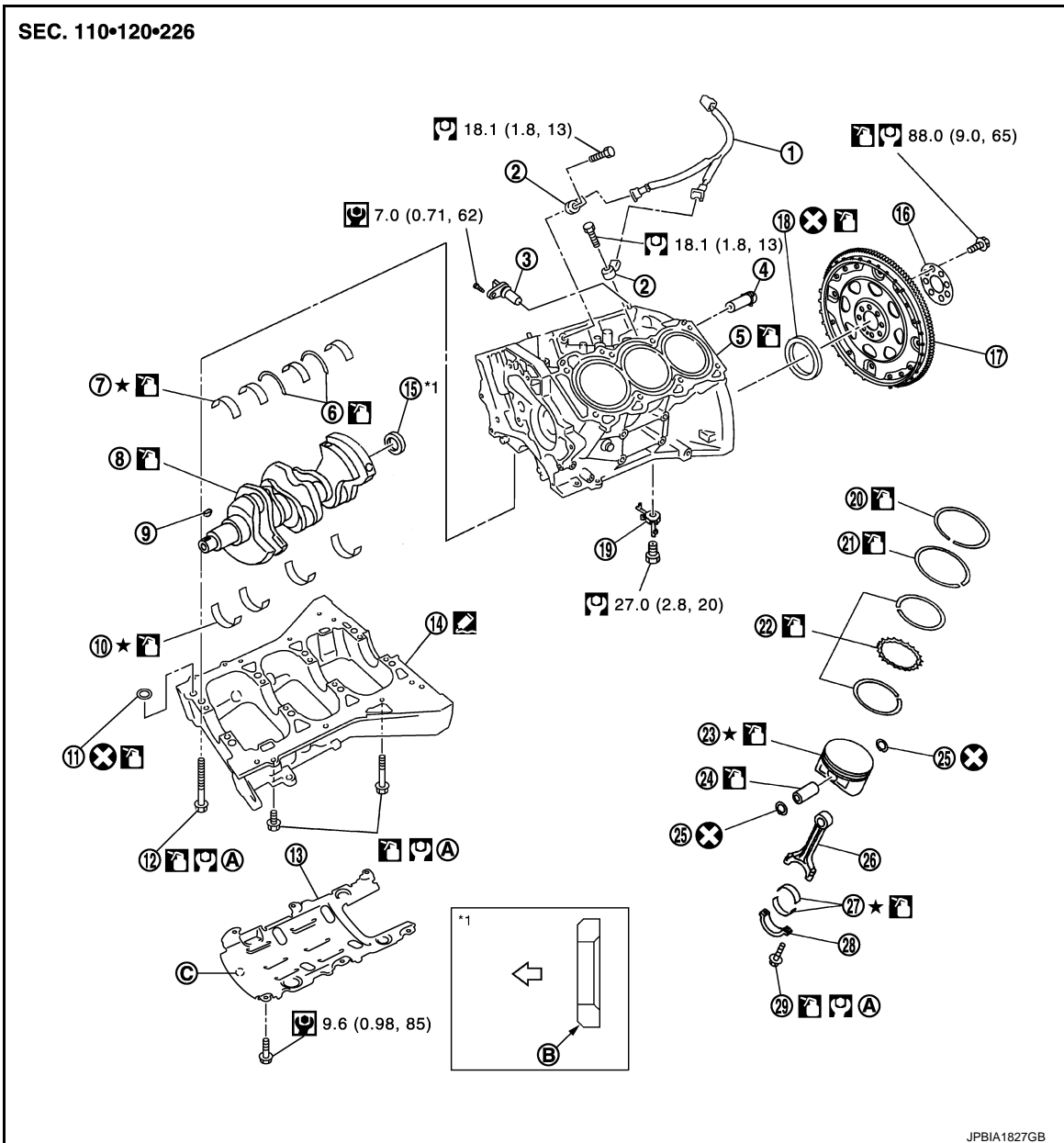

- | | | |
|---------------------------------------|--------------------------|-------------------------------|
| 1. Sub harness | 2. Knock sensor | 3. Crankshaft position sensor |
| 4. Cylinder block heater (for Canada) | 5. Cylinder block | 6. Thrust bearing |
| 7. Main bearing (upper) | 8. Crankshaft | 9. Crankshaft key |
| 10. Main bearing (lower) | 11. O-ring | 12. Lower cylinder block bolt |
| 13. Baffle plate | 14. Lower cylinder block | 15. Pilot converter |
| 16. Reinforcement plate | 17. Drive plate | 18. Rear oil seal |
| 19. Oil jet | 20. Top ring | 21. Second ring |
| 22. Oil ring | 23. Piston | 24. Piston pin |
| 25. Snap ring | 26. Connecting rod | 27. Connecting rod bearing |
| 28. Connecting rod bearing cap | 29. Connecting rod bolt | |
| A. Refer to EM-118 | B. Chamfered | C. Front mark |

CYLINDER BLOCK

< UNIT DISASSEMBLY AND ASSEMBLY >

[VQ35HR]

↩ : Crankshaft side

Refer to [GI-4, "Components"](#) for symbols in the figure.

Disassembly and Assembly

INFOID:000000003887390

DISASSEMBLY

1. Remove the following parts:
 - Oil pans (lower and upper): Refer to [EM-100, "2WD : Exploded View"](#) (2WD models) or [EM-103, "AWD : Exploded View"](#) (AWD models).
 - Front and rear timing chain case: Refer to [EM-53, "Exploded View"](#) and [EM-95, "Exploded View"](#).
 - Cylinder head: Refer to [EM-107, "Exploded View"](#).

2. Remove knock sensor.

CAUTION:

Carefully handle sensor avoiding shocks.

3. Remove baffle plate from lower cylinder block.

4. Remove piston and connecting rod assembly with the following procedure:

- Before removing piston and connecting rod assembly, check the connecting rod side clearance. Refer to [EM-147, "Cylinder Block"](#).

CAUTION:

Be careful not to drop connecting rod bearing, and to scratch the surface.

- a. Position crankshaft pin corresponding to connecting rod to be removed onto the bottom dead center.

- b. Remove connecting rod bearing cap.

- c. Using a hammer handle or similar tool, push piston and connecting rod assembly out to the cylinder head side.

CAUTION:

Be careful not to damage the cylinder wall and crankshaft pin, resulting from an interference of the connecting rod big end.

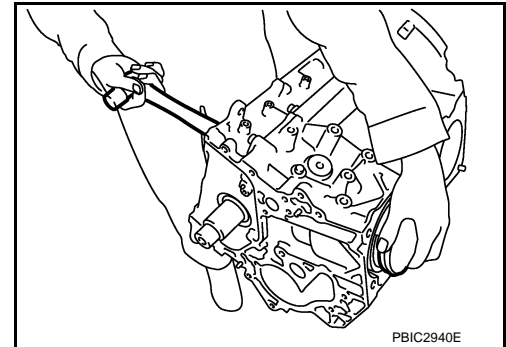

5. Remove connecting rod bearings from connecting rod and connecting rod bearing cap.

CAUTION:

- **Be careful not to drop connecting rod bearing, and to scratch the surface.**
- **Identify installation positions, and store them without mixing them up.**

6. Remove piston rings from piston.

- Before removing piston rings, check the piston ring side clearance. Refer to [EM-147, "Cylinder Block"](#).
- Use a piston ring expander (commercial service tool) (A).

CAUTION:

- **When removing piston rings, be careful not to damage piston.**
- **Be careful not to damage piston rings by expanding them excessively.**

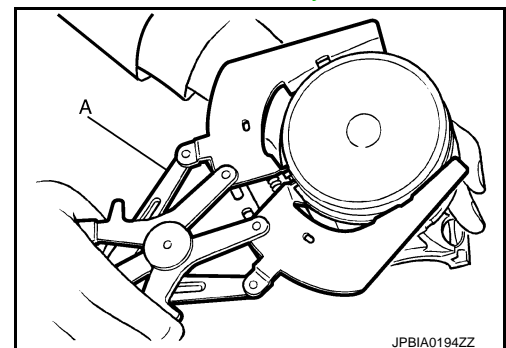

7. Remove piston from connecting rod as per the following:

CYLINDER BLOCK

< UNIT DISASSEMBLY AND ASSEMBLY >

[VQ35HR]

- a. Using a snap ring pliers (A), remove snap rings.

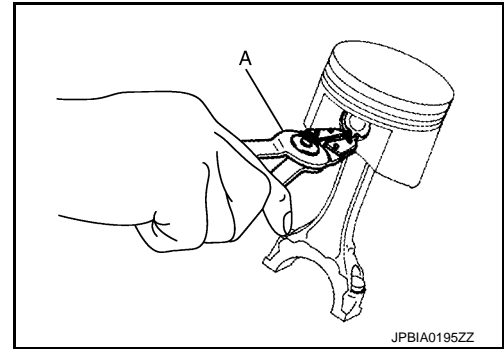

- b. Heat piston to 60 to 70°C (140 to 158°F) with an industrial use drier (A) or an equivalent.

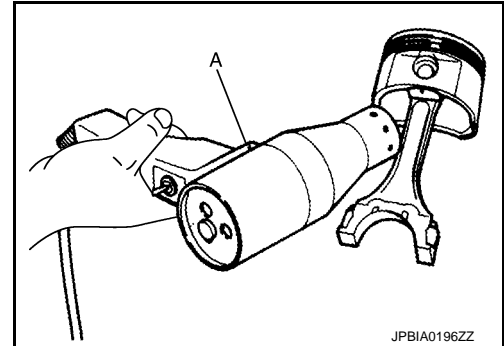

- c. Push out piston pin with stick of outer diameter approximately 20 mm (0.79 in).

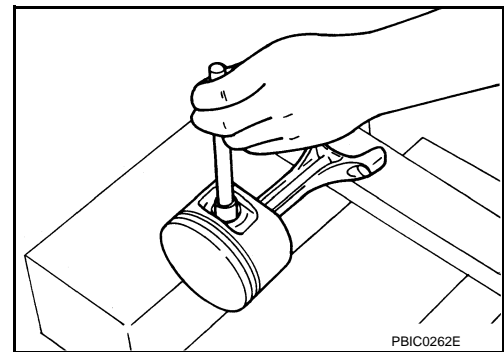

8. Remove lower cylinder block bolts.
- Before loosening lower cylinder block bolts, measure the crankshaft end play. Refer to [EM-147](#), "[Cylinder Block](#)".
 - Loosen lower cylinder block bolts in the reverse order shown in the figure in several different steps.

← : Engine front

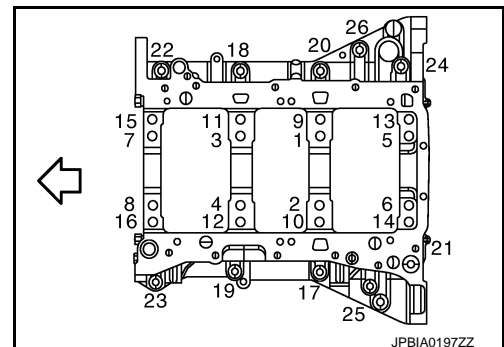

9. Remove lower cylinder block as per the following:

A
EM
C
D
E
F
G
H
I
J
K
L
M
N
O
P

CYLINDER BLOCK

[VQ35HR]

< UNIT DISASSEMBLY AND ASSEMBLY >

Screw M8 bolt [pitch: 1.25 mm (0.0492 in) length: approximately 50 mm (1.97 in)] into bolt holes (A). Then equally tighten each bolt, and remove lower cylinder block.

⇐ : Engine front

CAUTION:

- Be careful not to damage the mounting surfaces.
- Never tighten bolts too much.
- Never insert screw driver, this will damage the mating surface.

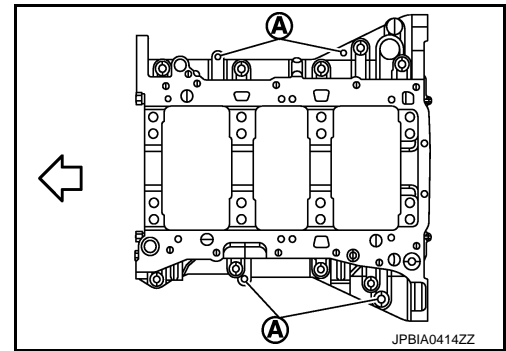

10. Remove crankshaft.
11. Pull rear oil seal out from rear end of crankshaft.
12. Remove main bearings and thrust bearings from cylinder block and lower cylinder block.

CAUTION:

- Be careful not to drop main bearing, and to scratch the surface.
- Identify installation positions, and store them without mixing them up.

13. Remove oil jet.

ASSEMBLY

1. Fully air-blow engine coolant and engine oil passages in cylinder block, cylinder bore and crankcase to remove any foreign material.

CAUTION:

Use a goggles to protect your eye.

2. Install each plug to cylinder block as shown in the figure.

3 : Plug

⇐ : Engine front

- Apply sealant to the thread of water drain plugs (1), (4).
Use Genuine RTV Silicone Sealant or an equivalent. Refer to [GI-15, "Recommended Chemical Products and Sealants"](#).
- Apply sealant to the thread of plugs.
Use Genuine high strength thread locking sealant or an equivalent. Refer to [GI-15, "Recommended Chemical Products and Sealants"](#).
- Replace washers (2) with new one.

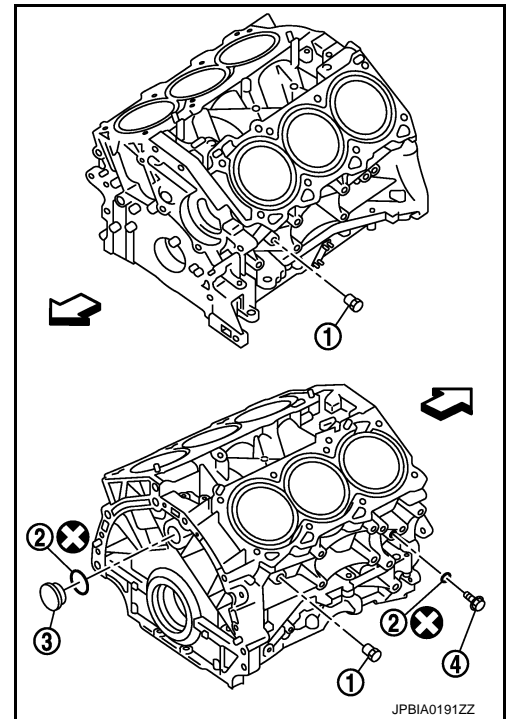

- Tighten each plug as specified below.

Part	Washer	Tightening torque
1	No	19.6 N·m (2.0 kg·m, 14 ft·lb)
3	Yes	78.0 N·m (8.0 kg·m, 58 ft·lb)
4	Yes	12.3 N·m (1.3 kg·m, 9 ft·lb)

3. Install oil jet.

CYLINDER BLOCK

< UNIT DISASSEMBLY AND ASSEMBLY >

[VQ35HR]

- Insert oil jet dowel pin (A) into cylinder block dowel pin hole, and tighten mounting bolts.

↶ : Engine front

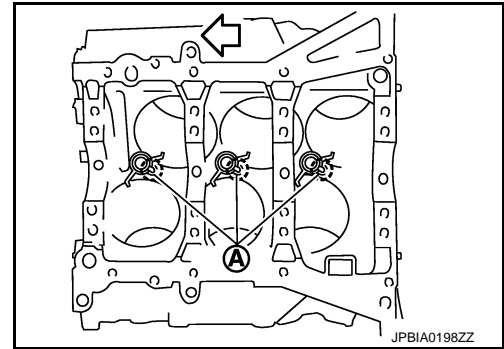

4. Install main bearings and thrust bearings as per the following:

CAUTION:

Be careful not to drop main bearing, and to scratch the surface.

- a. Remove dust, dirt, and engine oil on bearing mating surfaces of cylinder block and lower cylinder block.
- b. Install thrust bearings (1) to the both sides of the No. 3 journal housing on cylinder block.

A : No. 1

B : No. 2

C : No. 3

D : No. 4

F : Thrust bearing installation position

↶ : Engine front

- Install thrust bearings with the oil groove (E) facing crankshaft arm (outside).

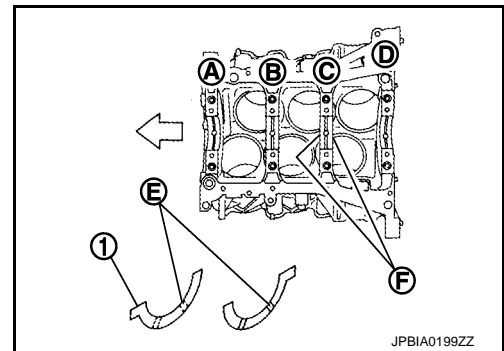

- c. Install main bearings paying attention to the direction.

A : Cylinder block side

D : Lower cylinder block side

↶ : Engine front

- Main bearing with oil hole (B) and groove (C) goes on cylinder block. The one without them goes on lower cylinder block.
- Before installing main bearings, apply engine oil to the bearing surface (inside). Do not apply engine oil to the back surface, but thoroughly clean it.
- When installing, align main bearing stopper protrusion to cut-out of cylinder block and lower cylinder block.
- Ensure the oil holes on cylinder block and those on the corresponding bearing are aligned.

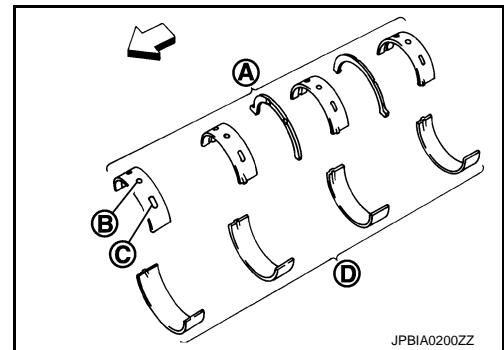

5. Install crankshaft to cylinder block.
 - While turning crankshaft by hand, check that it turns smoothly.
6. Install lower cylinder block.

NOTE:

Lower cylinder block cannot be replaced as a single part, because it is machined together with cylinder block.

A
EM
C
D
E
F
G
H
I
J
K
L
M
N
O
P

CYLINDER BLOCK

< UNIT DISASSEMBLY AND ASSEMBLY >

[VQ35HR]

- Apply a continuous bead of liquid gasket with the tube presser (commercial service tool) to lower cylinder block as shown in the figure.

B : Apply to end

a : $\phi 4.0 - 5.0$ mm (0.157 - 0.197 in)

Use Genuine RTV Silicone Sealant or an equivalent. Refer to [GI-15, "Recommended Chemical Products and Sealants"](#).

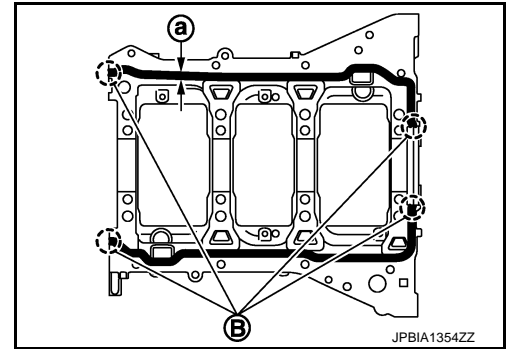

- Inspect the outer diameter of lower cylinder block bolt. Refer to [EM-126, "Inspection"](#).
- Install lower cylinder block bolts in numerical order as shown in the figure as per the following:
 - Apply new engine oil to threads and seat surfaces of lower cylinder block bolts.
 - Tighten lower cylinder block bolts (No. 17 to 26) in numerical order as shown in the figure.

← : Engine front

: **25.0 N·m (2.6 kg·m, 18 ft·lb)**

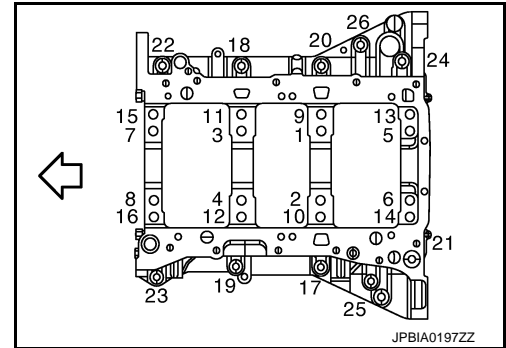

- Repeat step b.
- Tighten lower cylinder block bolt (No. 1 to 16) in numerical order as shown in the figure.

← : Engine front

: **35.3 N·m (3.6 kg·m, 26 ft·lb)**

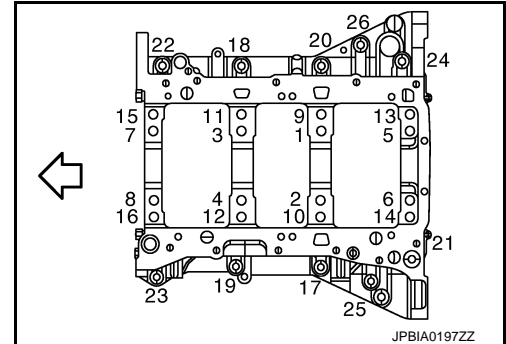

- Tighten lower cylinder block bolt No. 1 to 16 (clockwise).

Angle tightening: 90 degrees

CAUTION:

Use the angle wrench [SST: KV10112100 (BT8653-A)] (A) to check tightening angle. Never make judgment by visual inspection.

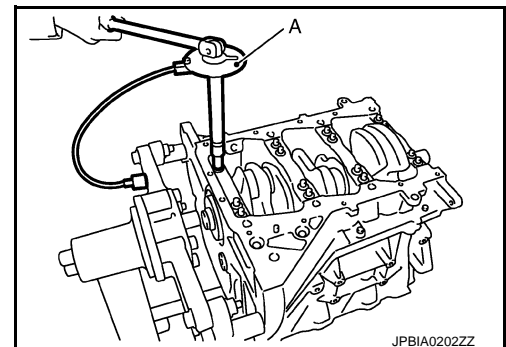

- After installing lower cylinder block bolts, check that crankshaft can be rotated smoothly by hand.
- Check the crankshaft end play. Refer to [EM-126, "Inspection"](#).

CYLINDER BLOCK

< UNIT DISASSEMBLY AND ASSEMBLY >

[VQ35HR]

9. Install piston to connecting rod as per the following:
 - a. Using a snap ring pliers, install new snap ring to the groove of piston rear side.
 - Insert it fully into groove to install.
 - b. Install piston to connecting rod.
 - Using an industrial use drier or similar tool, heat piston until piston pin can be pushed in by hand without excess force [approximately 60 to 70°C (140 to 158°F)]. From the front to the rear, insert piston pin into piston and connecting rod.
 - Assemble so that the front mark on the piston head and the cylinder number on connecting rod are positioned as shown in the figure.

- A : Piston grade number
- B : Front mark
- C : Pin grade number
- D : Cylinder number
- E : Front mark
- ↶ : Engine front

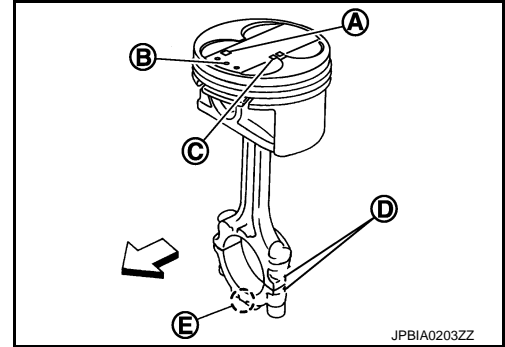

- c. Install new snap ring to the groove of the piston front side.
 - Insert it fully into groove to install.
 - After installing, check that connecting rod moves smoothly.

10. Using a piston ring expander (commercial service tool) (A), install piston rings.

CAUTION:

- When installing piston rings, be careful not to damage piston.
- Be careful not to damage piston rings by expanding them excessively.

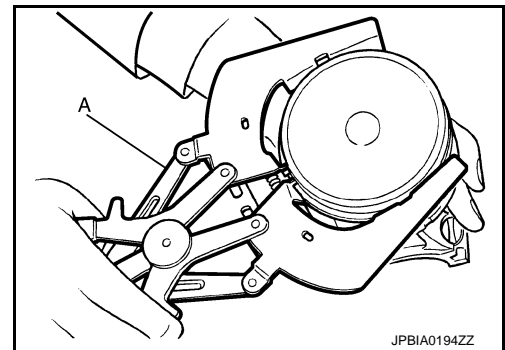

- If there is stamped mark on ring, mount it with marked side up.

Stamped mark:

- Top ring (A) : 1 N**
- Second ring (B) : 2 N**

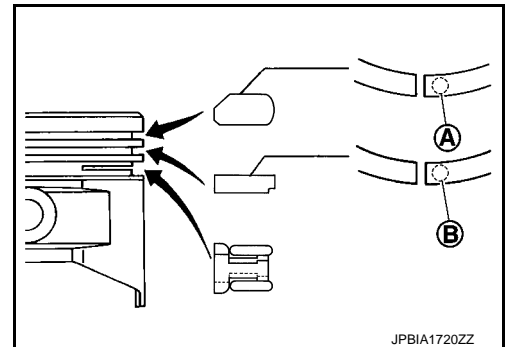

- Position each ring with the gap as shown in the figure referring to the piston front mark (D).

- C : Top ring gap
- E : Oil ring upper or lower rail gap (either of them)
- F : Second ring and oil ring spacer gap
- a : 90 degrees
- b : 45 degrees

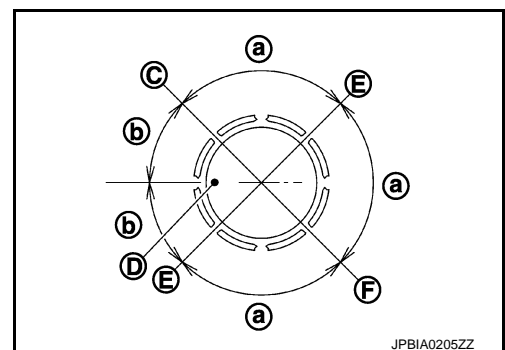

CYLINDER BLOCK

< UNIT DISASSEMBLY AND ASSEMBLY >

[VQ35HR]

- Check the piston ring side clearance. Refer to [EM-147. "Cylinder Block"](#).

11. Install connecting rod bearings to connecting rod and connecting rod bearing cap.

CAUTION:

Be careful not to drop connecting rod bearing, and to scratch the surface.

- Before installing connecting rod bearings, apply engine oil to the bearing surface (inside). Do not apply engine oil to the back surface, but thoroughly clean it.
- When installing, align connecting rod bearing stopper protrusion (B) with cutout (C) of connecting rods and connecting rod bearing caps to install.
- Ensure the oil hole (A) on connecting rod and that on the corresponding bearing are aligned.

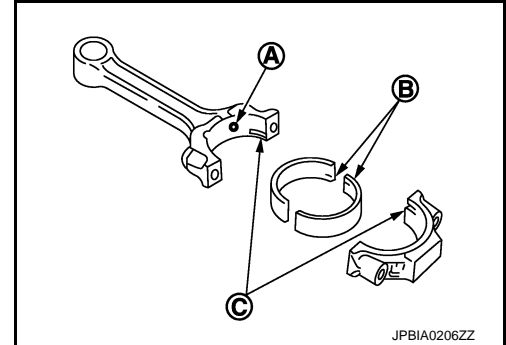

12. Install piston and connecting rod assembly to crankshaft.

- Position crankshaft pin corresponding to connecting rod to be installed onto the bottom dead center.
- Apply engine oil sufficiently to the cylinder bore, piston and crankshaft pin journal.
- Match the cylinder position with the cylinder number on connecting rod to install.
- Be sure that front mark on piston crown is facing front of engine.
- Using a piston ring compressor [SST: EM03470000 (J-8037)] (A) or suitable tool, install piston with the front mark on the piston crown facing the front of the engine.

CAUTION:

Be careful not to damage the cylinder wall and crankshaft pin, resulting from an interference of the connecting rod big end.

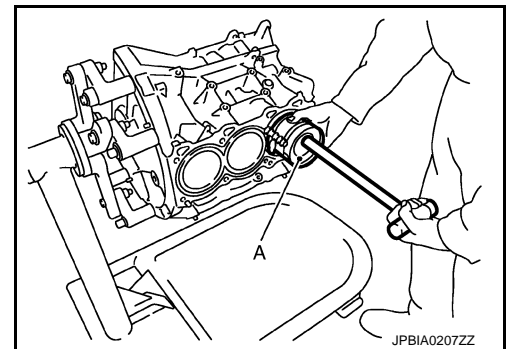

13. Install connecting rod bearing cap.

- Match the stamped cylinder number marks on connecting rod with those on connecting rod bearing cap to install.

- A : Sample codes
- B : Bearing stopper groove
- C : Small-end diameter grade
- D : Big-end diameter grade
- E : Weight grade
- F : Cylinder No.
- G : Management code
- I : Management code

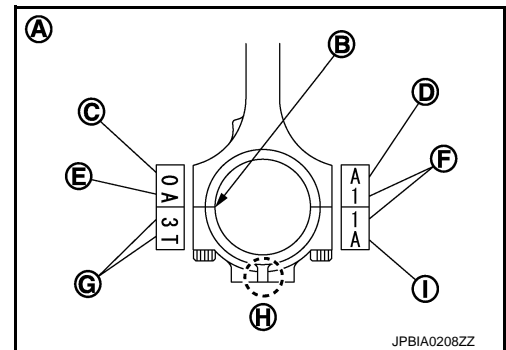

- Be sure that front mark (H) on connecting rod bearing cap is facing front of the engine.

14. Tighten connecting rod bolt as per the following:

- Inspect the outer diameter of connecting rod bolt. Refer to [EM-126. "Inspection"](#).
- Apply engine oil to the threads and seats of connecting rod bolts.
- Tighten connecting rod bolts.

: 28.4 N·m (2.9 kg·m, 21 ft·lb)

- Completely loosen connecting rod bolts.

CYLINDER BLOCK

< UNIT DISASSEMBLY AND ASSEMBLY >

[VQ35HR]

: 0 N·m (0 kg·m, 0 ft·lb)

e. Tighten connecting rod bolts.

: 24.5 N·m (2.5 kg·m, 18 ft·lb)

f. Tighten connecting rod bolts (clockwise).

Angle tightening: 90 degrees

CAUTION:

Always use the angle wrench [SST: KV10112100 (BT8653-A)] (A). Never tightening based on visual check alone.

- After tightening connecting rod bolts, check that crankshaft rotates smoothly.
- Check the connecting rod side clearance. Refer to [EM-126, "Inspection"](#).

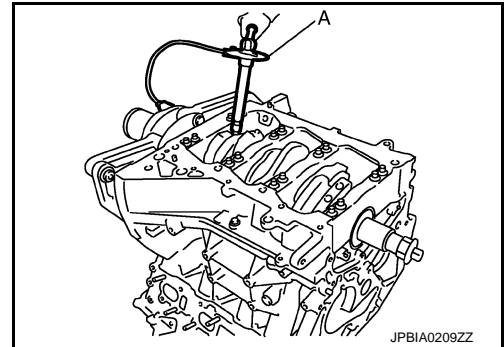

15. Install baffle plate.

16. Install new rear oil seal. Refer to [EM-80, "REAR OIL SEAL : Removal and Installation"](#).

- Apply new engine oil to both oil seal lip and dust seal lip.

17. Install pilot converter.

- With a drift of the following outer diameter, press-fit as far as it will go.

Pilot converter : Approximately 33 mm (1.30 in)

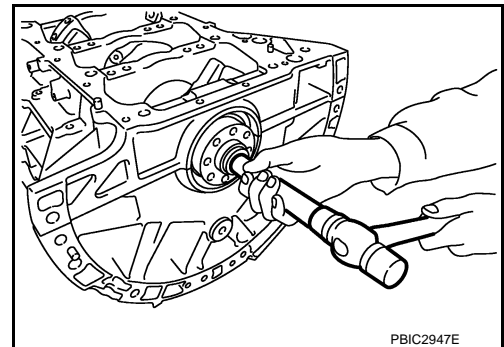

- Press-fit pilot converter with its chamfer facing crankshaft as shown in the figure.

 : Crankshaft side

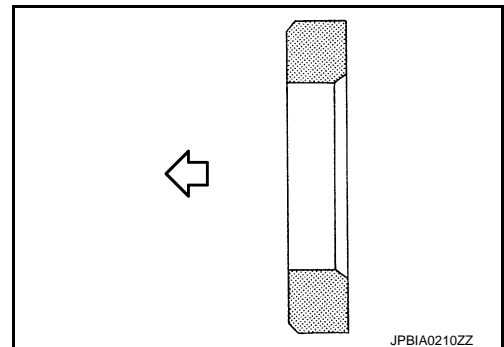

CYLINDER BLOCK

< UNIT DISASSEMBLY AND ASSEMBLY >

[VQ35HR]

18. Install knock sensors.

- A : Bank 1
- B : Bank 2
- ⇐ : Engine front

- Install knock sensor so that connector faces rear of the engine.
- After installing knock sensor, connect harness connector, and lay it out to rear of the engine.

CAUTION:

- **Never tighten mounting bolts while holding connector.**
- **If any impact by dropping is applied to knock sensor, replace it with new one.**

NOTE:

- Check that there is no foreign material on the cylinder block mating surface and the back surface of knock sensor.
- Check that knock sensor does not interfere with other parts.

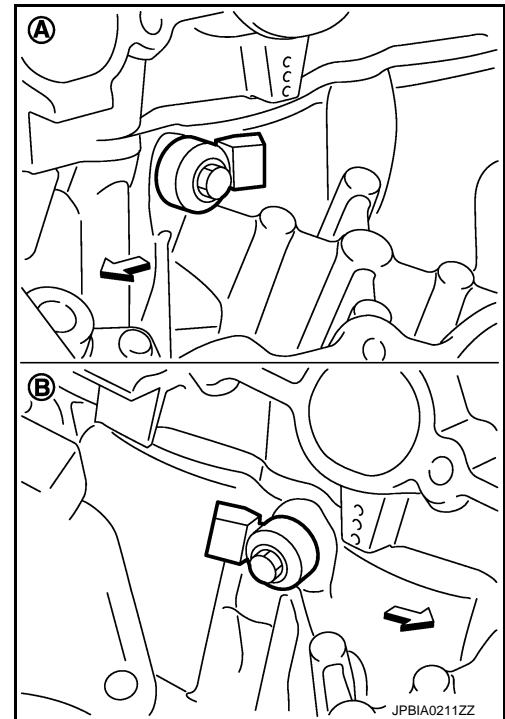

19. Note the following item, assemble in the reverse order of disassembly after this step.

Drive plate

- When installing drive plate to crankshaft, be sure to correctly align crankshaft side dowel pin and drive plate side dowel pin hole.

CAUTION:

If these are not aligned correctly, engine runs roughly and "MIL" turns on.

- Install drive plate (2) and reinforcement plate (3) as shown in the figure.

- 1 : Ring gear
- 4 : Pilot converter
- 5 : Crankshaft
- A : Rounded
- ⇐ : Engine front

- Holding ring gear with the ring gear stopper [SST: KV10118600 (J-48641)].
- Tighten the mounting bolts crosswise over several times.

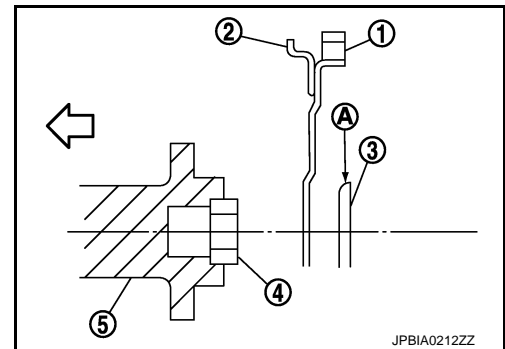

Inspection

INFOID:000000003887391

CRANKSHAFT END PLAY

- Measure the clearance between thrust bearings and crankshaft arm when crankshaft is moved fully forward or backward with a dial indicator.

Standard and limit : Refer to EM-147, "Cylinder Block".

- If the measured value exceeds the limit, replace thrust bearings, and measure again. If it still exceeds the limit, replace crankshaft also.

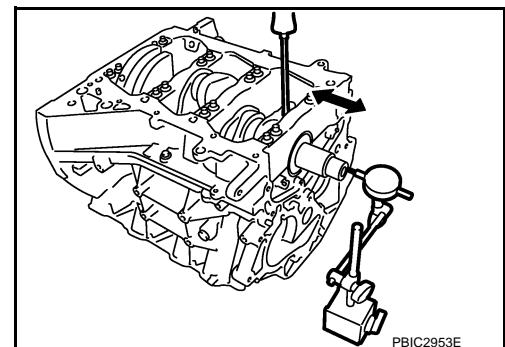

CONNECTING ROD SIDE CLEARANCE

CYLINDER BLOCK

< UNIT DISASSEMBLY AND ASSEMBLY >

[VQ35HR]

- Measure the side clearance between connecting rod and crankshaft arm with a feeler gauge.

Standard and limit : Refer to [EM-147, "Cylinder Block"](#).

- If the measured value exceeds the limit, replace connecting rod, and measure again. If it still exceeds the limit, replace crankshaft also.

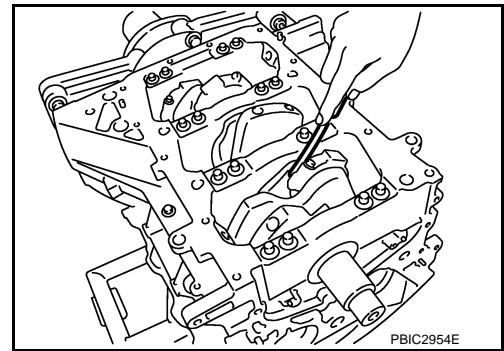

PISTON TO PISTON PIN OIL CLEARANCE

Piston Pin Hole Diameter

Measure the inner diameter of piston pin hole with an inside micrometer (A).

Standard : Refer to [EM-147, "Cylinder Block"](#).

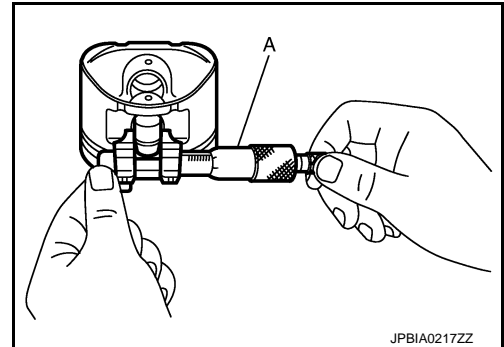

Piston Pin Outer Diameter

Measure the outer diameter of piston pin with a micrometer (A).

Standard : Refer to [EM-147, "Cylinder Block"](#).

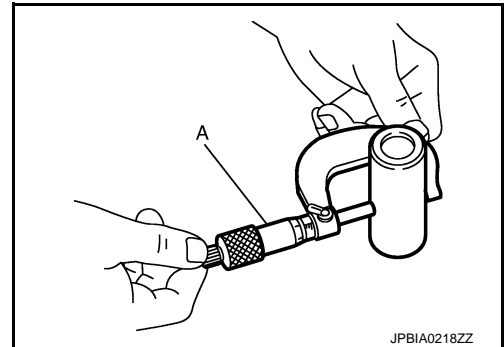

Piston to Piston Pin Oil Clearance

$(\text{Piston to piston pin oil clearance}) = (\text{Piston pin hole diameter}) - (\text{Piston pin outer diameter})$

Standard : Refer to [EM-147, "Cylinder Block"](#).

- If the calculated value is out of the standard, replace piston and piston pin assembly.
- When replacing piston and piston pin assembly, refer to [EM-136, "Description"](#).

NOTE:

- Piston is available together with piston pin as assembly.
- Piston pin (piston pin hole) grade is provided only for the parts installed at the plant. For service parts, no piston pin grades can be selected. (Only "0" grade is available.)

PISTON RING SIDE CLEARANCE

CYLINDER BLOCK

[VQ35HR]

< UNIT DISASSEMBLY AND ASSEMBLY >

- Measure the side clearance of piston ring (1) and piston ring groove with a feeler gauge (C).

A : OK
B : NG

Standard and limit : Refer to [EM-147, "Cylinder Block"](#).

- If the measured value exceeds the limit, replace piston ring, and measure again. If it still exceeds the limit, replace piston also.

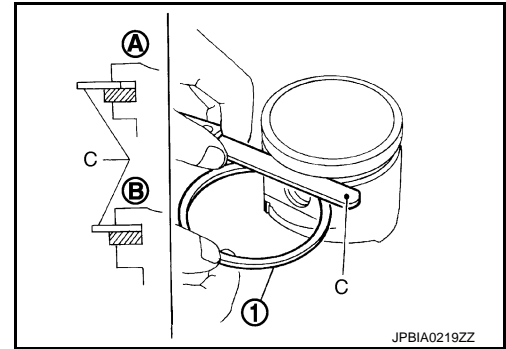

PISTON RING END GAP

- Check that the cylinder bore inner diameter is within the specification. Refer to [EM-118, "Disassembly and Assembly"](#).
- Lubricate with new engine oil to piston (1) and piston ring (2), and then insert piston ring until middle of cylinder with piston, and measure the piston ring end gap with a feeler gauge (B).

A : Press-fit
C : Measuring point

Standard and limit : Refer to [EM-147, "Cylinder Block"](#).

- If the measured value exceeds the limit, replace piston ring, and measure again. If it still exceeds the limit, rebore cylinder and use oversize piston and piston rings.

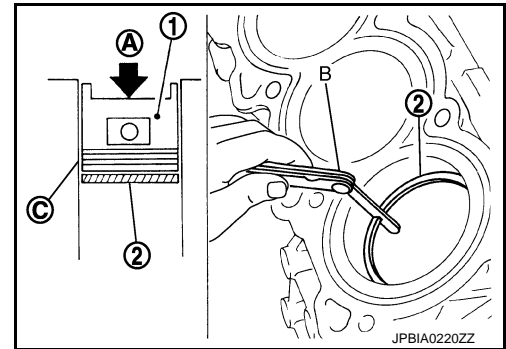

CONNECTING ROD BEND AND TORSION

- Check with a connecting rod aligner.

A : Bend
B : Torsion
C : Feeler gauge

Bend limit
Torsion limit : Refer to [EM-147, "Cylinder Block"](#).

- If it exceeds the limit, replace connecting rod assembly.

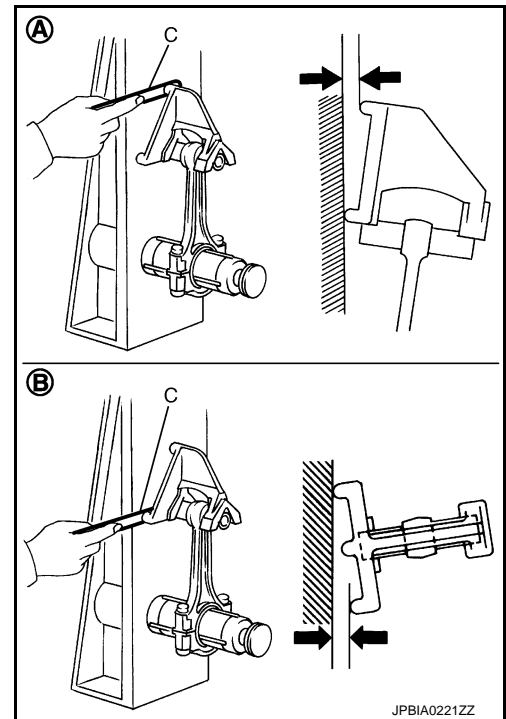

CONNECTING ROD BIG END DIAMETER

CYLINDER BLOCK

< UNIT DISASSEMBLY AND ASSEMBLY >

[VQ35HR]

- Install connecting rod bearing cap without installing connecting rod bearing, and tightening connecting rod bolts to the specified torque. Refer to [EM-118. "Disassembly and Assembly"](#) for the tightening procedure.

1 : Connecting rod

- Measure the inner diameter of connecting rod big end with an inside micrometer.

Standard : Refer to [EM-147. "Cylinder Block"](#).

- If out of the standard, replace connecting rod assembly.

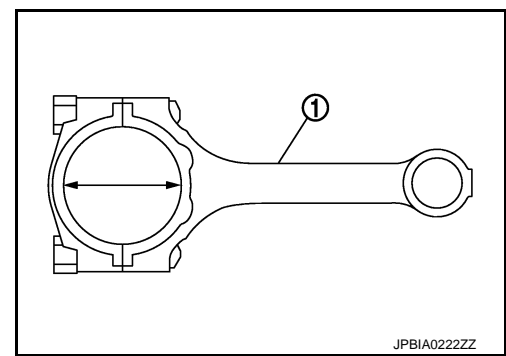

CONNECTING ROD BUSHING OIL CLEARANCE

Connecting Rod Bushing Inner Diameter

Measure the inner diameter of connecting rod bushing with an inside micrometer (A).

Standard : Refer to [EM-147. "Cylinder Block"](#).

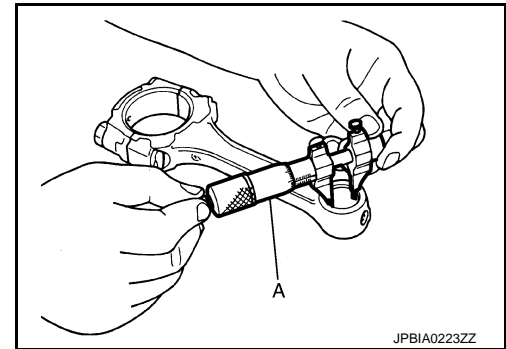

Piston Pin Outer Diameter

Measure the outer diameter of piston pin with a micrometer (A).

Standard : Refer to [EM-147. "Cylinder Block"](#).

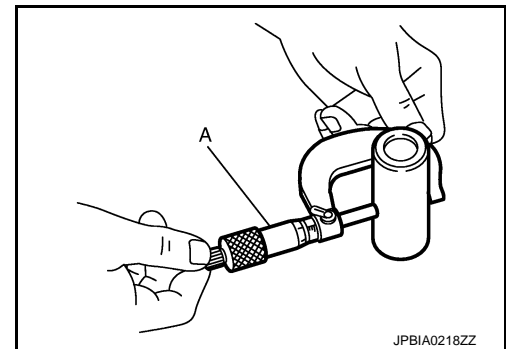

Connecting Rod Bushing Oil Clearance

(Connecting rod bushing oil clearance) = (Connecting rod bushing inner diameter) – (Piston pin outer diameter)

Standard and limit : Refer to [EM-147. "Cylinder Block"](#).

- If the calculated value exceeds the limit, replace connecting rod assembly and/or piston and piston pin assembly.
- If replacing piston and piston pin assembly, refer to [EM-136. "Description"](#).
- If replacing connecting rod assembly, refer to [EM-137. "Connecting Rod Bearing"](#) to select the connecting rod bearing.

- A : Sample codes
- B : Bearing stopper groove
- C : Small-end diameter grade
- D : Big-end diameter grade
- E : Weight grade
- F : Cylinder No.
- G : Management code

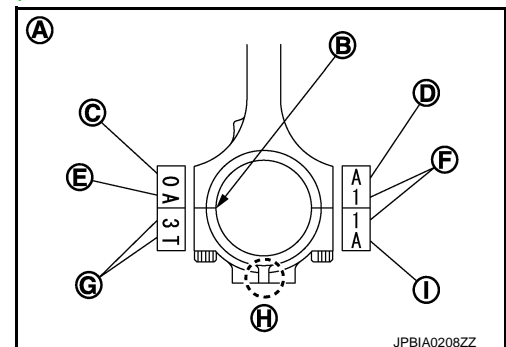

CYLINDER BLOCK

< UNIT DISASSEMBLY AND ASSEMBLY >

[VQ35HR]

- H : Front mark
- I : Management code

Factory installed parts grading:

- Service parts apply only to grade "0".

- A : Piston grade number
- B : Front mark
- C : Piston pin grade number

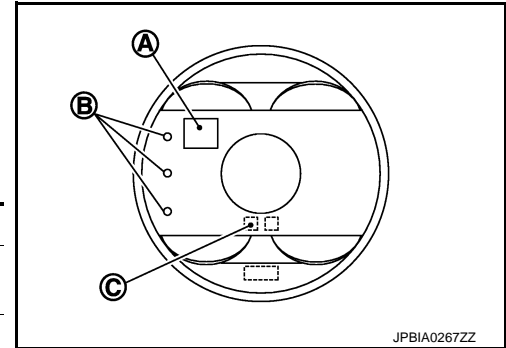

Grade	Unit: mm (in)	
	0	1
Connecting rod bushing inner diameter *	22.000 - 22.006 (0.8661 - 0.8664)	22.006 - 22.012 (0.8664 - 0.8666)
Piston pin hole diameter	21.993 - 21.999 (0.8659 - 0.8661)	21.999 - 22.005 (0.8661 - 0.8663)
Piston pin outer diameter	21.989 - 21.995 (0.8657 - 0.8659)	21.995 - 22.001 (0.8659 - 0.8662)

*: After installing in connecting rod

CYLINDER BLOCK DISTORTION

- Using a scraper, remove gasket on the cylinder block surface, and also remove engine oil, scale, carbon, or other contamination.

CAUTION:

Be careful not to allow gasket flakes to enter engine oil or engine coolant passages.

- Measure the distortion on the cylinder block upper face at some different points in six directions (C, D, E, F, G, and H) with a straightedge (A) and a feeler gauge (B).

Limit : Refer to [EM-147, "Cylinder Block"](#).

- If it exceeds the limit, replace cylinder block.

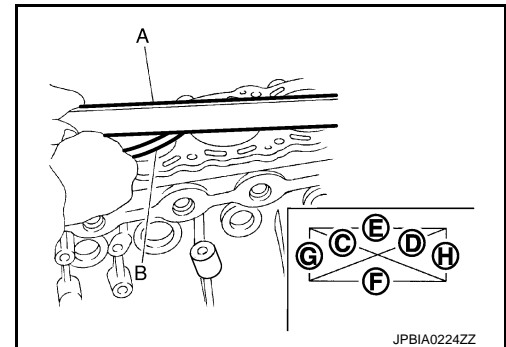

MAIN BEARING HOUSING INNER DIAMETER

- Install lower cylinder block (2) without installing main bearings, and tighten lower cylinder block bolts to the specified torque. Refer to [EM-118, "Disassembly and Assembly"](#) for the tightening procedure.
- Measure the inner diameter of main bearing housing with a bore gauge.

Standard : Refer to [EM-147, "Cylinder Block"](#).

- If out of the standard, replace cylinder block (1) and lower cylinder block as assembly.

NOTE:

Cylinder block cannot be replaced as a single part, because it is machined together with lower cylinder block.

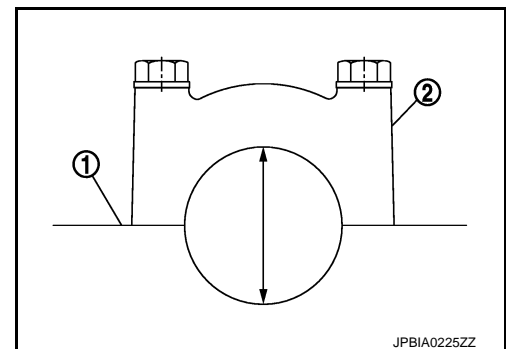

PISTON TO CYLINDER BORE CLEARANCE

Cylinder Bore inner Diameter

CYLINDER BLOCK

[VQ35HR]

< UNIT DISASSEMBLY AND ASSEMBLY >

- Using a bore gauge, measure cylinder bore for wear, out-of-round and taper at six different points on each cylinder. [(A) and (B) directions at (C), (D) and (E)] is in longitudinal direction of engine.

- f** : 10 mm (0.39 in)
- g** : 60 mm (2.36 in)
- h** : 125 mm (4.92 in)

Standard and limit : Refer to [EM-147, "Cylinder Block"](#).

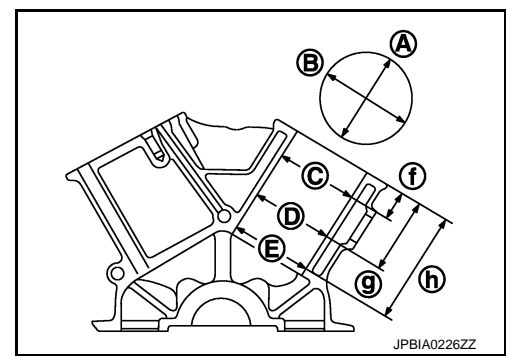

- If the measured value exceeds the limit, or if there are scratches and/or seizure on the cylinder inner wall, hone or rebore the inner wall.
- Oversize piston is provided. When using oversize piston, rebore cylinder so that the clearance of the piston to cylinder bore satisfies the standard.

CAUTION:

When using oversize piston, use oversize pistons for all cylinders with oversize piston rings.

Oversize (O/S) : 0.2 mm (0.008 in)

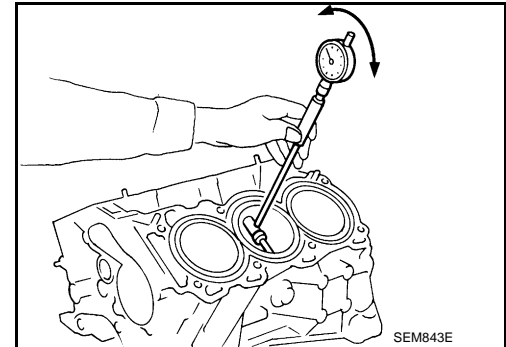

Piston Skirt Diameter

Measure the outer diameter of piston skirt with a micrometer (A).

Measure point
Standard : Refer to [EM-147, "Cylinder Block"](#).

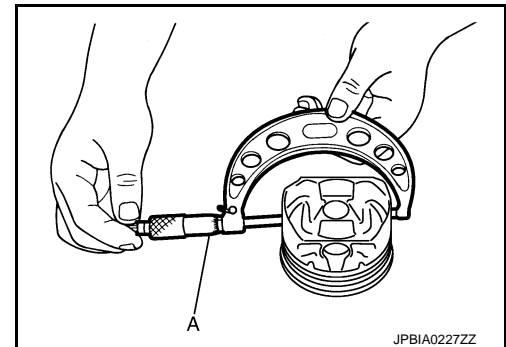

Piston-to-Cylinder Bore Clearance

Calculate by piston skirt diameter and cylinder bore inner diameter [direction (B), position (D)].

(Clearance) = (Cylinder bore inner diameter) – (Piston skirt diameter).

Standard and limit : Refer to [EM-147, "Cylinder Block"](#).

- If the calculated value exceeds the limit, replace piston and piston pin assembly. Refer to [EM-136, "Piston"](#).

Re-boring Cylinder Bore

- Cylinder bore size is determined by adding piston to cylinder bore clearance to piston skirt diameter.

Re-bored size calculation: $D = A + B - C$

where,

- A: Piston skirt diameter as measured**
- B: Piston to cylinder bore clearance (standard value)**
- C: Honing allowance 0.02 mm (0.0008 in)**
- D: Bored diameter**

- Install lower cylinder block, and tighten to the specified torque. Otherwise, cylinder bores may be distorted in final assembly.
- Cut cylinder bores.

NOTE:

CYLINDER BLOCK

[VQ35HR]

< UNIT DISASSEMBLY AND ASSEMBLY >

- When any cylinder needs boring, all other cylinders must also be bored.
 - Do not cut too much out of cylinder bore at a time. Cut only 0.05 mm (0.0020 in) or so in diameter at a time.
4. Hone cylinders to obtain the specified piston to cylinder bore clearance.
 5. Measure finished cylinder bore for the out-of-round and taper.

NOTE:

Measurement should be done after cylinder bore cools down.

CRANKSHAFT MAIN JOURNAL DIAMETER

- Measure the outer diameter of crankshaft main journals with a micrometer.

Standard : Refer to [EM-147, "Cylinder Block"](#).

- If out of the standard, measure the main bearing oil clearance. Then use undersize bearing. Refer to [EM-139, "Main Bearing"](#).

CRANKSHAFT PIN JOURNAL DIAMETER

- Measure the outer diameter of crankshaft pin journal with a micrometer (A).

Standard : Refer to [EM-147, "Cylinder Block"](#).

- If out of the standard, measure the connecting rod bearing oil clearance. Then use undersize bearing. Refer to [EM-137, "Connecting Rod Bearing"](#).

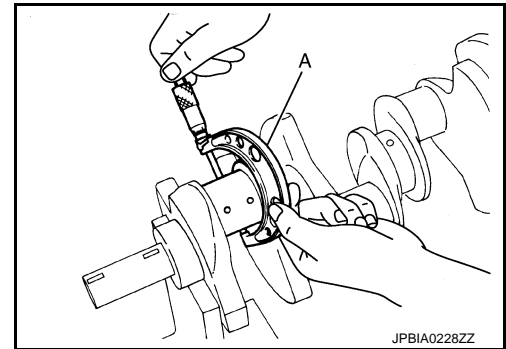

CRANKSHAFT OUT-OF-ROUND AND TAPER

- Measure the dimensions at four different points as shown in the figure on each main journal and pin journal with a micrometer.
- Out-of-round is indicated by the difference in the dimensions between (d) and (c) at (a) and (b).
- Taper is indicated by the difference in the dimensions between.

Limit : Refer to [EM-147, "Cylinder Block"](#).

- If the measured value exceeds the limit, correct or replace crankshaft.
- If corrected, measure the bearing oil clearance of the corrected main journal and/or pin journal. Then select the main bearing and/or connecting rod bearing. Refer to [EM-139, "Main Bearing"](#) and/or [EM-137, "Connecting Rod Bearing"](#).

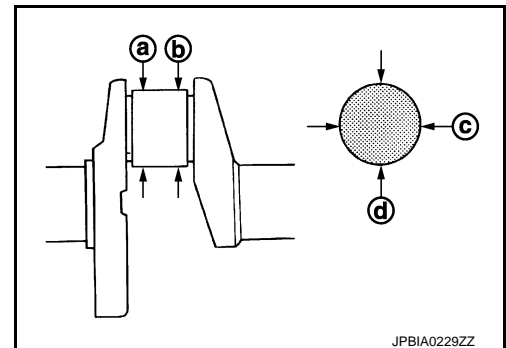

CRANKSHAFT RUNOUT

- Place V-block on precise flat table, and support the journals on the both end of crankshaft.
- Place a dial indicator straight up on the No. 3 journal.
- While rotating crankshaft, read the movement of the pointer on a dial indicator. (Total indicator reading)

Standard and limit : Refer to [EM-147, "Cylinder Block"](#).

- If it exceeds the limit, replace crankshaft.

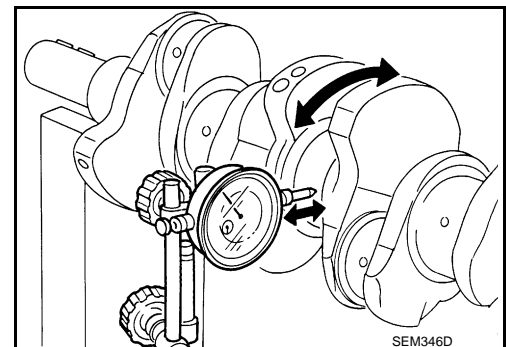

CONNECTING ROD BEARING OIL CLEARANCE

Method by Calculation

CYLINDER BLOCK

[VQ35HR]

< UNIT DISASSEMBLY AND ASSEMBLY >

- Install connecting rod bearings (1) to connecting rod (2) and connecting rod cap, and tighten connecting rod bolts to the specified torque. Refer to [EM-118, "Disassembly and Assembly"](#) for the tightening procedure.
- Measure the inner diameter of connecting rod bearing with an inside micrometer.
(Oil clearance) = (Connecting rod bearing inner diameter) – (Crankshaft pin journal diameter)

Standard and limit : Refer to [EM-152, "Connecting Rod Bearing"](#).

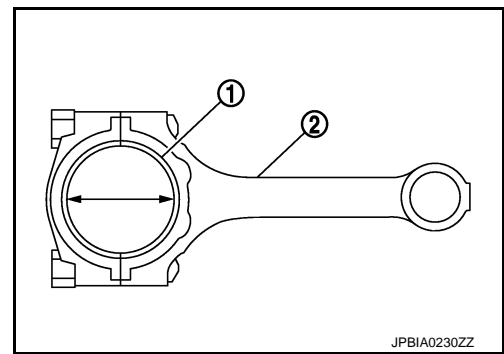

- If the calculated value exceeds the limit, select proper connecting rod bearing according to connecting rod big end diameter and crankshaft pin journal diameter to obtain the specified bearing oil clearance. Refer to [EM-137, "Connecting Rod Bearing"](#).

Method of Using Plastigage

- Remove oil and dust on crankshaft pin journal and the surfaces of each bearing completely.
- Cut a plastigage slightly shorter than the bearing width, and place it in crankshaft axial direction, avoiding oil holes.
- Install connecting rod bearings to connecting rod and connecting rod bearing cap, and tighten connecting rod bolts to the specified torque. Refer to [EM-118, "Disassembly and Assembly"](#) for the tightening procedure.

CAUTION:

Never rotate crankshaft.

- Remove connecting rod bearing cap and bearings, and using the scale on the plastigage bag, measure the plastigage width.

NOTE:

The procedure when the measured value exceeds the limit is same as that described in the "Method by Calculation".

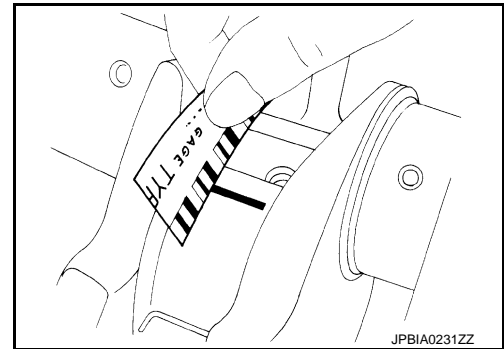

MAIN BEARING OIL CLEARANCE

Method by Calculation

- Install main bearings (3) to cylinder block (1) and lower cylinder block (2), and tighten lower cylinder block bolts to the specified torque. Refer to [EM-118, "Disassembly and Assembly"](#) for the tightening procedure.
- Measure the inner diameter of main bearing with a bore gauge.
(Oil clearance) = (Main bearing inner diameter) – (Crankshaft main journal diameter)

Standard and limit : Refer to [EM-151, "Main Bearing"](#).

- If the calculated value exceeds the limit, select proper main bearing according to main bearing inner diameter and crankshaft main journal diameter to obtain the specified bearing oil clearance. Refer to [EM-139, "Main Bearing"](#).

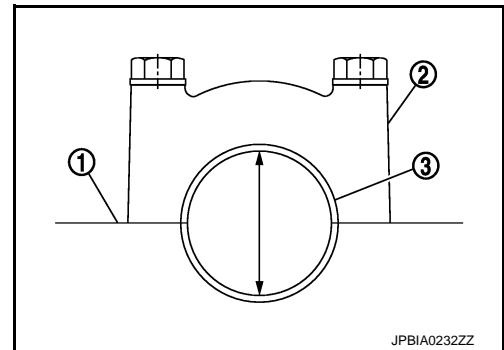

Method of Using Plastigage

- Remove engine oil and dust on crankshaft journal and the surfaces of each bearing completely.
- Cut a plastigage slightly shorter than the bearing width, and place it in crankshaft axial direction, avoiding oil holes.
- Install main bearing to cylinder block and lower cylinder block, and tighten lower cylinder block bolts with lower cylinder block to the specified torque. Refer to [EM-118, "Disassembly and Assembly"](#) for the tightening procedure.

CAUTION:

CYLINDER BLOCK

< UNIT DISASSEMBLY AND ASSEMBLY >

[VQ35HR]

Never rotate crankshaft.

- Remove lower cylinder block and bearings, and using the scale on the plastigage bag, measure the plastigage width.

NOTE:

The procedure when the measured value exceeds the limit is same as that described in the "Method by Calculation".

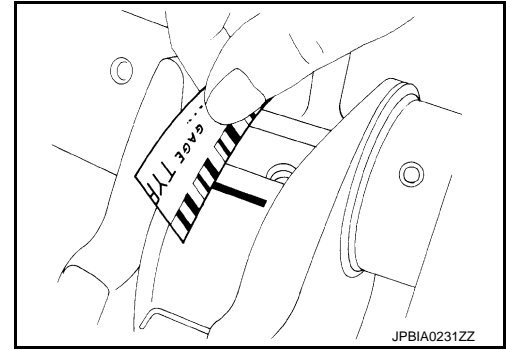

MAIN BEARING CRUSH HEIGHT

- When lower cylinder block is removed after being tightened to the specified torque with main bearings (1) installed, the tip end of bearing must protrude. Refer to [EM-118, "Disassembly and Assembly"](#) for the tightening procedure.

A : Crush height

Standard : There must be crush height.

- If the standard is not met, replace main bearings.

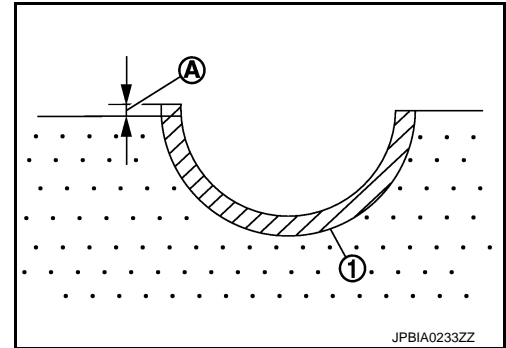

CONNECTING ROD BEARING CRUSH HEIGHT

- When connecting rod bearing cap is removed after being tightened to the specified torque with connecting rod bearings (1) installed, the tip end of bearing must protrude. Refer to [EM-118, "Disassembly and Assembly"](#) for the tightening procedure.

A : Crush height

Standard : There must be crush height.

- If the standard is not met, replace connecting rod bearings.

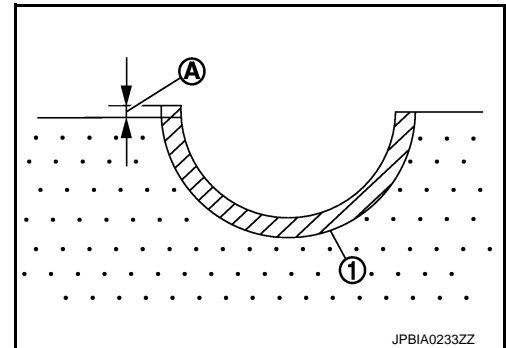

LOWER CYLINDER BLOCK BOLT OUTER DIAMETER

- Measure the outer diameters (c), (d) at two positions as shown in the figure.

a : 20 mm (0.79 in)

b : 30 mm (1.18 in)

e : 10 mm (0.39 in)

- If reduction appears in (a) range, regard it (c).

Limit [(d) – (c)] : 0.11 mm (0.0043 in)

- If it exceeds the limit (large difference in dimensions), replace lower cylinder block bolt with new one.

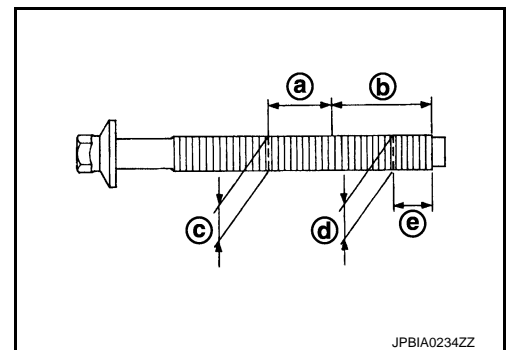

CONNECTING ROD BOLT OUTER DIAMETER

CYLINDER BLOCK

< UNIT DISASSEMBLY AND ASSEMBLY >

[VQ35HR]

1. Measure the outer diameters [(a), (b) and (c)] at the position shown in the figure.
 - a : Value at the end of the smaller diameter of the bolt
 - b : Value at the end of the smaller diameter of the bolt [opposite side of (a)]
 - c : Value of the smallest diameter of the smaller of the bolt
2. Obtain a mean value (d) of (a) and (b).
3. Subtract (c) from (d).

Limit [(d) – (c)] : 0.09 mm (0.0035 in)

4. If it exceeds the limit (large difference in dimensions), replace the bolt with new one.

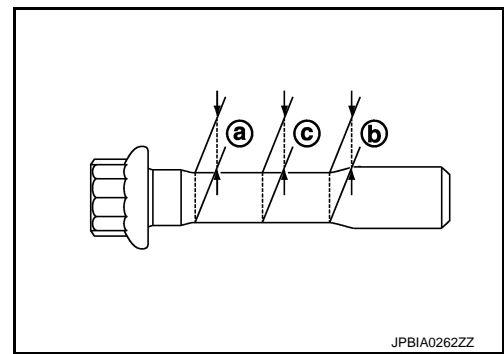

DRIVE PLATE

- Check drive plate and signal plate for deformation or damage.

CAUTION:

- **Never disassemble drive plate.**
- **Never place drive plate with signal plate facing down.**
- **When handling signal plate, take care not to damage or scratch it.**
- **Handle signal plate in a manner that prevents it from becoming magnetized.**
- If damage is found, replace drive plate.

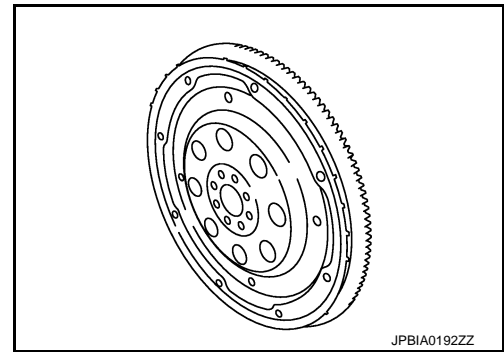

OIL JET

- Check nozzle for deformation and damage.
- Blow compressed air from nozzle, and check for clogs.
- If it is not satisfied, clean or replace oil jet.

OIL JET RELIEF VALVE

- Using a clean plastic stick, press check valve in oil jet relief valve. Check that valve moves smoothly with proper reaction force.
- If it is not satisfied, replace oil jet relief valve.

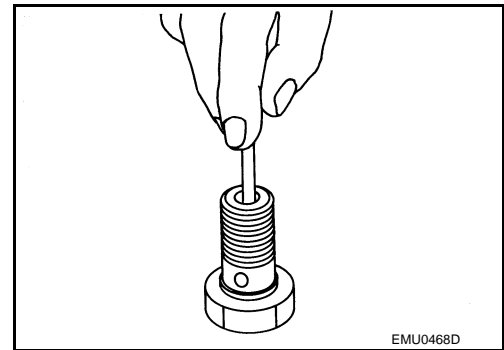

A
EM
C
D
E
F
G
H
I
J
K
L
M
N
O
P

HOW TO SELECT PISTON AND BEARING

< UNIT DISASSEMBLY AND ASSEMBLY >

[VQ35HR]

HOW TO SELECT PISTON AND BEARING

Description

INFOID:000000003887392

Selection points	Selection parts	Selection items	Selection methods
Between cylinder block and crankshaft	Main bearing	Main bearing grade (bearing thickness)	Determined by match of cylinder block bearing housing grade (inner diameter of housing) and crankshaft journal grade (outer diameter of journal)
Between crankshaft and connecting rod	Connecting rod bearing	Connecting rod bearing grade (bearing thickness)	Combining service grades for connecting rod big end diameter and crankshaft pin outer diameter determine connecting rod bearing selection.
Between cylinder block and piston	Piston and piston pin assembly (Piston is available together with piston pin as assembly.)	Piston grade (piston skirt diameter)	Piston grade = cylinder bore grade (inner diameter of bore)
Between piston and connecting rod*	—	—	—

*: For the service parts, the grade for fitting cannot be selected between piston pin and connecting rod. (Only "0" grade is available.) The information at the shipment from the plant is described as a reference.

- The identification grade stamped on each part is the grade for the dimension measured in new condition. This grade cannot apply to reused parts.
- For reused or repaired parts, measure the dimension accurately. Determine the grade by comparing the measurement with the values of each selection table.
- For details of the measurement method of each part, the reuse standards and the selection method of the selective fitting parts, refer to the text.

Piston

INFOID:000000003887393

WHEN NEW CYLINDER BLOCK IS USED

Check the cylinder bore grade ("1", "2" or "3") on rear side of cylinder block, and select piston of the same grade.

- A : Bearing housing grade No. 1
- B : Bearing housing grade No. 2
- C : Bearing housing grade No. 3
- D : Bearing housing grade No. 4
- E : Cylinder bore grade No. 1
- F : Cylinder bore grade No. 2
- G : Cylinder bore grade No. 3
- H : Cylinder bore grade No. 4
- I : Cylinder bore grade No. 5
- J : Cylinder bore grade No. 6
- K : Identification
- ↶ : Engine front

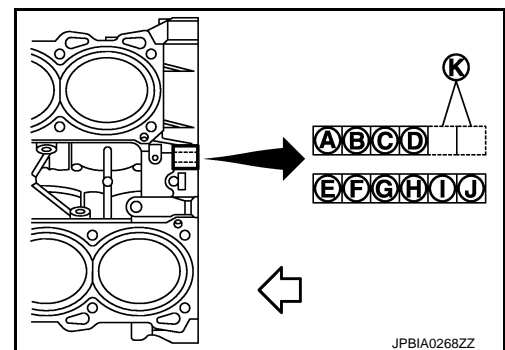

NOTE:

Piston is available with piston pin as a set for the service part. (Only "0" grade piston pin is available.)

WHEN NEW CYLINDER BLOCK IS REUSED

1. Measure the cylinder bore inner diameter. Refer to [EM-147, "Cylinder Block"](#).

HOW TO SELECT PISTON AND BEARING

< UNIT DISASSEMBLY AND ASSEMBLY >

[VQ35HR]

- Determine the bore grade by comparing the measurement with the values under the cylinder bore inner diameter of the "PISTON SELECTION TABLE".

- A : Piston grade number
- B : Front mark
- C : Piston pin grade number

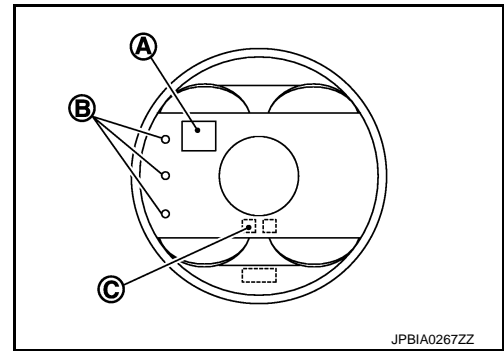

- Select piston of the same grade.

PISTON SELECTION TABLE

Unit: mm (in)

Grade	1	2	3
Cylinder bore inner diameter	95.500 - 95.510 (3.7598 - 3.7602)	95.510 - 95.520 (3.7602 - 3.7606)	95.520 - 95.530 (3.7606 - 3.7610)
Piston skirt diameter	95.480 - 95.490 (3.7590 - 3.7594)	95.490 - 95.500 (3.7594 - 3.7598)	95.500 - 95.510 (3.7598 - 3.7602)

NOTE:

- Piston is available together with piston pin as assembly.
- Piston pin (piston pin hole) grade is provided only for the parts installed at the plant. For service parts, no piston pin grades can be selected. (Only "0" grade is available.)
- No second grade mark is available on piston.

Connecting Rod Bearing

INFOID:0000000003887394

WHEN NEW CONNECTING ROD AND CRANKSHAFT ARE USED

- Apply connecting rod big end diameter grade stamped (D) on connecting rod side face to the row in the "CONNECTING ROD BEARING SELECTION TABLE".

- A : Sample codes
- B : Bearing stopper groove
- C : Small-end diameter grade
- E : Weight grade
- F : Cylinder No.
- G : Management code
- H : Front mark
- I : Management code

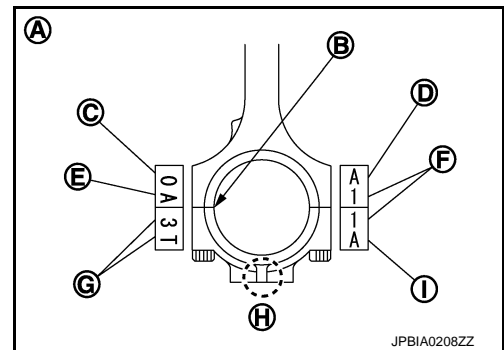

- Apply crankshaft pin journal diameter grade stamped on crankshaft front side to the column in the "CONNECTING ROD BEARING SELECTION TABLE"

- A : Journal diameter grade No. 1
- B : Journal diameter grade No. 2
- C : Journal diameter grade No. 3
- D : Journal diameter grade No. 4
- E : Pin diameter grade No. 1
- F : Pin diameter grade No. 2
- G : Pin diameter grade No. 3
- H : Pin diameter grade No. 4
- I : Pin diameter grade No. 5

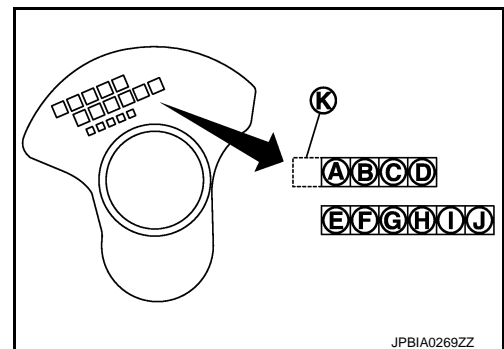

HOW TO SELECT PISTON AND BEARING

[VQ35HR]

< UNIT DISASSEMBLY AND ASSEMBLY >

- J : Pin diameter grade No. 6
- K : Identification

3. Read the symbol at the cross point of selected row and column in the "CONNECTING ROD BEARING SELECTION TABLE".
4. Apply the symbol obtained to the "CONNECTING ROD BEARING GRADE TABLE" to select connecting rod bearing.

WHEN CONNECTING ROD AND CRANKSHAFT ARE REUSED

1. Measure the connecting rod big end diameter. Refer to [EM-147, "Cylinder Block"](#).
2. Check that the connecting rod big end diameter is within the standard value.
3. Measure the crankshaft pin journal diameter. Refer to [EM-147, "Cylinder Block"](#).
4. Determine the grade of crankshaft pin diameter grade by corresponding to the measured dimension in "Crankshaft pin journal diameter" column of "CONNECTING ROD BEARING SELECTION TABLE".
5. Select connecting rod bearing of the same grade.

CONNECTING ROD BEARING SELECTION TABLE

Connecting rod big end diameter Unit: mm (in)		Crankshaft pin journal diameter Unit: mm (in)													
		Mark													
Mark		Axle diameter													
		Hole diameter													
		57.000 - 57.001 (2.2441 - 2.2441)	57.001 - 57.002 (2.2441 - 2.2442)	57.002 - 57.003 (2.2442 - 2.2442)	57.003 - 57.004 (2.2442 - 2.2442)	57.004 - 57.005 (2.2442 - 2.2443)	57.005 - 57.006 (2.2443 - 2.2443)	57.006 - 57.007 (2.2443 - 2.2444)	57.007 - 57.008 (2.2444 - 2.2444)	57.008 - 57.009 (2.2444 - 2.2444)	57.009 - 57.010 (2.2444 - 2.2445)	57.010 - 57.011 (2.2445 - 2.2445)	57.011 - 57.012 (2.2445 - 2.2446)	57.012 - 57.013 (2.2446 - 2.2446)	
A	53.974 - 53.973 (2.1250 - 2.1249)	0	0	0	0	0	0	1	1	1	1	1	1	2	
B	53.973 - 53.972 (2.1249 - 2.1249)	0	0	0	0	0	1	1	1	1	1	1	1	2	
C	53.972 - 53.971 (2.1249 - 2.1248)	0	0	0	0	1	1	1	1	1	1	2	2	2	
D	53.971 - 53.970 (2.1248 - 2.1248)	0	0	0	1	1	1	1	1	1	2	2	2	2	
E	53.970 - 53.969 (2.1248 - 2.1248)	0	0	1	1	1	1	1	1	2	2	2	2	2	
F	53.969 - 53.968 (2.1248 - 2.1247)	0	1	1	1	1	1	1	2	2	2	2	2	2	
G	53.968 - 53.967 (2.1247 - 2.1247)	1	1	1	1	1	1	2	2	2	2	2	2	3	
H	53.967 - 53.966 (2.1247 - 2.1246)	1	1	1	1	1	2	2	2	2	2	2	3	3	
J	53.966 - 53.965 (2.1246 - 2.1246)	1	1	1	1	2	2	2	2	2	2	3	3	3	
K	53.965 - 53.964 (2.1246 - 2.1246)	1	1	1	2	2	2	2	2	2	3	3	3	3	
L	53.964 - 53.963 (2.1246 - 2.1245)	1	1	2	2	2	2	2	2	3	3	3	3	3	
M	53.963 - 53.962 (2.1245 - 2.1245)	1	2	2	2	2	2	2	3	3	3	3	3	3	
N	53.962 - 53.961 (2.1245 - 2.1244)	2	2	2	2	2	2	3	3	3	3	3	3	4	
P	53.961 - 53.960 (2.1244 - 2.1244)	2	2	2	2	2	3	3	3	3	3	3	4	4	
R	53.960 - 53.959 (2.1244 - 2.1244)	2	2	2	2	3	3	3	3	3	3	4	4	4	
S	53.959 - 53.958 (2.1244 - 2.1243)	2	2	2	3	3	3	3	3	3	4	4	4	4	
T	53.958 - 53.957 (2.1243 - 2.1243)	2	2	3	3	3	3	3	3	4	4	4	4	4	
U	53.957 - 53.956 (2.1243 - 2.1242)	2	3	3	3	3	3	3	4	4	4	4	4	4	

PBIC5435E

CONNECTING ROD BEARING GRADE TABLE

[Connecting rod bearing grade table](#) : Refer to [EM-152, "Connecting Rod Bearing"](#).

UNDERSIZE BEARING USAGE GUIDE

HOW TO SELECT PISTON AND BEARING

< UNIT DISASSEMBLY AND ASSEMBLY >

[VQ35HR]

- When the specified connecting rod bearing oil clearance is not obtained with standard size connecting rod bearings, use undersize (US) bearings.
- When using undersize (US) bearing, measure the connecting rod bearing inner diameter with bearing installed, and grind crankshaft pin so that the connecting rod bearing oil clearance satisfies the standard.

CAUTION:

In grinding crankshaft pin to use undersize bearings, keep the fillet R (A) [1.5 - 1.7 mm (0.059 - 0.067 in)].

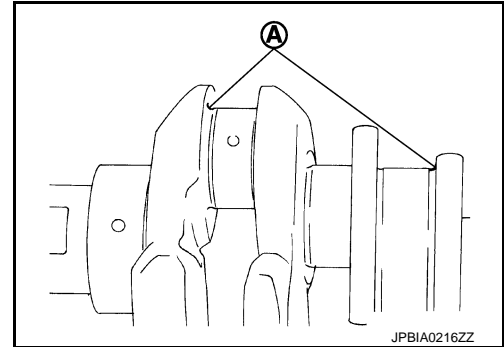

Bearing undersize table : Refer to [EM-152, "Connecting Rod Bearing"](#).

Main Bearing

INFOID:000000003887395

WHEN NEW CYLINDER BLOCK AND CRANKSHAFT ARE USED

1. "MAIN BEARING SELECTION TABLE" rows correspond to bearing housing grade on rear left side of cylinder block.

- A : Bearing housing grade No. 1
- B : Bearing housing grade No. 2
- C : Bearing housing grade No. 3
- D : Bearing housing grade No. 4
- E : Cylinder bore grade No. 1
- F : Cylinder bore grade No. 2
- G : Cylinder bore grade No. 3
- H : Cylinder bore grade No. 4
- I : Cylinder bore grade No. 5
- J : Cylinder bore grade No. 6
- K : Identification code
- ↶ : Engine front

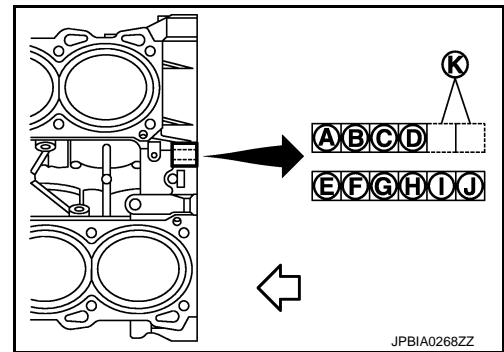

2. "MAIN BEARING SELECTION TABLE" columns correspond to journal diameter grade on front side of crankshaft.

- A : Journal diameter grade No. 1
- B : Journal diameter grade No. 2
- C : Journal diameter grade No. 3
- D : Journal diameter grade No. 4
- E : Pin diameter grade No. 1
- F : Pin diameter grade No. 2
- G : Pin diameter grade No. 3
- H : Pin diameter grade No. 4
- I : Pin diameter grade No. 5
- J : Pin diameter grade No. 6
- K : Identification code

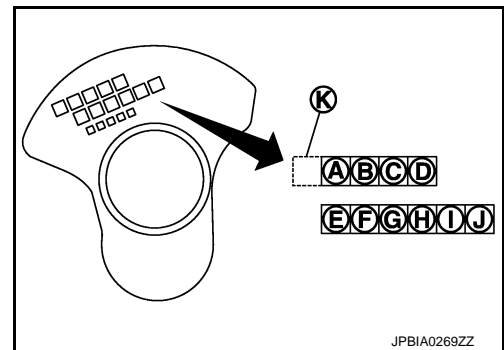

3. Select main bearing grade at the point where selected row and column meet in "MAIN BEARING SELECTION TABLE".

HOW TO SELECT PISTON AND BEARING

[VQ35HR]

< UNIT DISASSEMBLY AND ASSEMBLY >

4. Apply sign at crossing in above step 3 to "MAIN BEARING GRADE TABLE".

NOTE:

- "MAIN BEARING GRADE TABLE" applies to all journals.
- Service parts is available as a set of both upper and lower.

WHEN CYLINDER BLOCK AND CRANKSHAFT ARE REUSED

1. Measure cylinder block main bearing housing inner diameter and crankshaft main journal diameter. Refer to [EM-147, "Cylinder Block"](#).
2. Correspond the measured dimension in "Cylinder block main bearing housing inner diameter" row of "MAIN BEARING SELECTION TABLE".
3. Correspond the measured dimension in "Crankshaft main journal diameter" column of "MAIN BEARING SELECTION TABLE".
4. Follow from step 3 in "When New Cylinder Block and Crankshaft are Used".

MAIN BEARING SELECTION TABLE

Mark	Axle diameter	Cylinder block main bearing housing inner diameter Unit: mm (in)							Crankshaft main journal diameter Unit: mm (in)																
		A	B	C	D	E	F	G	H	J	K	L	M	N	P	R	S	T	U	V	W	X	Y	4	7
A	64.975 - 64.974 (2.5581 - 2.5580)	0	0	0	0	0	1	1	1	1	1	1	1	1	1	1	1	1	1	1	1	1	1	1	1
B	64.974 - 64.973 (2.5580 - 2.5580)	0	0	0	1	0	1	0	1	1	1	1	1	1	1	1	1	1	1	1	1	1	1	1	1
C	64.973 - 64.972 (2.5580 - 2.5579)	0	0	1	0	1	0	1	1	1	1	1	1	1	1	1	1	1	1	1	1	1	1	1	1
D	64.972 - 64.971 (2.5579 - 2.5579)	0	1	0	1	0	1	1	1	1	1	1	1	1	1	1	1	1	1	1	1	1	1	1	1
E	64.971 - 64.970 (2.5579 - 2.5579)	0	1	0	1	1	1	1	1	1	1	1	1	1	1	1	1	1	1	1	1	1	1	1	1
F	64.970 - 64.969 (2.5579 - 2.5578)	0	1	1	1	1	1	1	1	1	1	1	1	1	1	1	1	1	1	1	1	1	1	1	1
G	64.969 - 64.968 (2.5578 - 2.5578)	1	1	1	1	1	1	1	1	1	1	1	1	1	1	1	1	1	1	1	1	1	1	1	1
H	64.968 - 64.967 (2.5578 - 2.5578)	1	1	1	1	1	1	1	1	1	1	1	1	1	1	1	1	1	1	1	1	1	1	1	1
J	64.967 - 64.966 (2.5578 - 2.5577)	1	1	1	1	1	1	1	1	1	1	1	1	1	1	1	1	1	1	1	1	1	1	1	1
K	64.966 - 64.965 (2.5577 - 2.5577)	1	1	1	1	1	1	1	1	1	1	1	1	1	1	1	1	1	1	1	1	1	1	1	1
L	64.965 - 64.964 (2.5577 - 2.5576)	1	1	1	1	1	1	1	1	1	1	1	1	1	1	1	1	1	1	1	1	1	1	1	1
M	64.964 - 64.963 (2.5576 - 2.5576)	1	1	1	1	1	1	1	1	1	1	1	1	1	1	1	1	1	1	1	1	1	1	1	1
N	64.963 - 64.962 (2.5576 - 2.5576)	1	1	1	1	1	1	1	1	1	1	1	1	1	1	1	1	1	1	1	1	1	1	1	1
P	64.962 - 64.961 (2.5576 - 2.5575)	1	1	1	1	1	1	1	1	1	1	1	1	1	1	1	1	1	1	1	1	1	1	1	1
R	64.961 - 64.960 (2.5575 - 2.5575)	1	1	1	1	1	1	1	1	1	1	1	1	1	1	1	1	1	1	1	1	1	1	1	1
S	64.960 - 64.959 (2.5575 - 2.5574)	1	1	1	1	1	1	1	1	1	1	1	1	1	1	1	1	1	1	1	1	1	1	1	1
T	64.959 - 64.958 (2.5574 - 2.5574)	1	1	1	1	1	1	1	1	1	1	1	1	1	1	1	1	1	1	1	1	1	1	1	1
U	64.958 - 64.957 (2.5574 - 2.5574)	1	1	1	1	1	1	1	1	1	1	1	1	1	1	1	1	1	1	1	1	1	1	1	1
V	64.957 - 64.956 (2.5574 - 2.5573)	1	1	1	1	1	1	1	1	1	1	1	1	1	1	1	1	1	1	1	1	1	1	1	1
W	64.956 - 64.955 (2.5573 - 2.5573)	1	1	1	1	1	1	1	1	1	1	1	1	1	1	1	1	1	1	1	1	1	1	1	1
X	64.955 - 64.954 (2.5573 - 2.5572)	1	1	1	1	1	1	1	1	1	1	1	1	1	1	1	1	1	1	1	1	1	1	1	1
Y	64.954 - 64.953 (2.5572 - 2.5572)	1	1	1	1	1	1	1	1	1	1	1	1	1	1	1	1	1	1	1	1	1	1	1	1
4	64.953 - 64.952 (2.5572 - 2.5572)	1	1	1	1	1	1	1	1	1	1	1	1	1	1	1	1	1	1	1	1	1	1	1	1
7	64.952 - 64.951 (2.5572 - 2.5571)	1	1	1	1	1	1	1	1	1	1	1	1	1	1	1	1	1	1	1	1	1	1	1	1

JPBIA0264ZZ

MAIN BEARING GRADE TABLE (ALL JOURNALS)

Main bearing grade table (All journals) : Refer to [EM-151, "Main Bearing"](#).

UNDERSIZE BEARING USAGE GUIDE

- When the specified main bearing oil clearance is not obtained with standard size main bearings, use under-size (US) bearing.
- When using under-size (US) bearing, measure the main bearing inner diameter with bearing installed, and grind main journal so that the main bearing oil clearance satisfies the standard.

HOW TO SELECT PISTON AND BEARING

< UNIT DISASSEMBLY AND ASSEMBLY >

[VQ35HR]

CAUTION:

In grinding crankshaft main journal to use undersize bearings, keep the fillet R (A) [1.5 - 1.7 mm (0.059 - 0.067 in)].

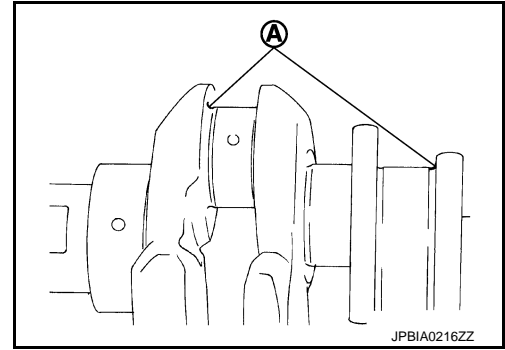

A

EM

C

D

Bearing undersize table : Refer to [EM-151, "Main Bearing"](#).

E

F

G

H

I

J

K

L

M

N

O

P

SERVICE DATA AND SPECIFICATIONS (SDS)

< SERVICE DATA AND SPECIFICATIONS (SDS)

[VQ35HR]

SERVICE DATA AND SPECIFICATIONS (SDS)

SERVICE DATA AND SPECIFICATIONS (SDS)

General Specification

INFOID:000000003887396

GENERAL SPECIFICATIONS

Cylinder arrangement		V-6
Displacement cm ³ (cu in)		3,498 (213.45)
Bore and stroke mm (in)		95.5 x 81.4 (3.760 x 3.205)
Valve arrangement		DOHC
Firing order		1-2-3-4-5-6
Number of piston rings	Compression	2
	Oil	1
Number of main bearings		4
Compression ratio		10.6
Compression pressure kPa (kg/cm ² , psi)/300 rpm	Standard	1,275 (13.0, 185)
	Minimum	981 (10.0, 142)
	Differential limit between cylinders	98 (1.0, 14)

Cylinder number

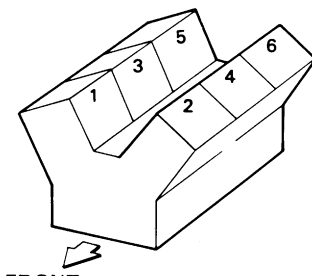

SEM713A

Valve timing
(Valve timing control - "OFF")

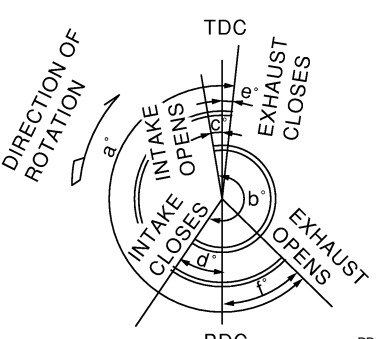

PBIC0187E

Unit: degree

a	b	c	d	e	f
248	248	2	66	0	68

Drive Belt

INFOID:000000003887397

DRIVE BELT

Tension of drive belt	Belt tension is not necessary, as it is automatically adjusted by drive belt auto-tensioner.
-----------------------	--

SERVICE DATA AND SPECIFICATIONS (SDS)

< SERVICE DATA AND SPECIFICATIONS (SDS)

[VQ35HR]

Spark Plug

INFOID:000000003887398

SPARK PLUG

Unit: mm (in)

Make	DENSO	
Standard type	FXE22HR11	
Gap	Standard	1.1 (0.043)
	Limit	1.4 (0.055)

Intake Manifold

INFOID:000000003887399

INTAKE MANIFOLD

Unit: mm (in)

Items		Limit
Surface distortion	Intake manifold	0.1 (0.004)

Exhaust Manifold

INFOID:000000003887400

EXHAUST MANIFOLD

Unit: mm (in)

Items		Limit
Surface distortion	Exhaust manifold	0.7 (0.028)

Camshaft

INFOID:000000003887401

CAMSHAFT

Unit: mm (in)

Items		Standard	Limit
Camshaft journal oil clearance	No. 1	0.045 - 0.086 (0.0018 - 0.0034)	0.15 (0.0059)
	No. 2, 3, 4	0.035 - 0.076 (0.0014 - 0.0030)	
Camshaft bracket inner diameter	No. 1	26.000 - 26.021 (1.0236 - 1.0244)	—
	No. 2, 3, 4	23.500 - 23.521 (0.9252 - 0.9260)	—
Camshaft journal diameter	No. 1	25.935 - 25.955 (1.0211 - 1.0218)	—
	No. 2, 3, 4	23.445 - 23.465 (0.9230 - 0.9238)	—
Camshaft end play		0.115 - 0.188 (0.0045 - 0.0074)	0.24 (0.0094)
Camshaft cam height "A"	Intake	45.865 - 46.055 (1.8057 - 1.8132)	0.2 (0.008)* ¹
	Exhaust	45.875 - 46.065 (1.8061 - 1.8136)	0.2 (0.008)* ¹
Camshaft runout [TIR* ²]		Less than 0.02 (0.0008)	0.05 (0.0020)
Camshaft sprocket runout [TIR* ²]		—	0.15 (0.0059)

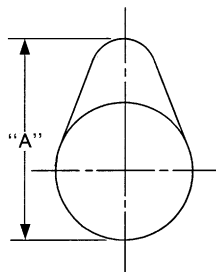

SEM671

SERVICE DATA AND SPECIFICATIONS (SDS)

< SERVICE DATA AND SPECIFICATIONS (SDS)

[VQ35HR]

*1: Cam wear limit

*2: Total indicator reading

VALVE LIFTER

Unit: mm (in)

Items	Standard
Valve lifter outer diameter	33.980 - 33.990 (1.3378 - 1.3382)
Valve lifter hole diameter	34.000 - 34.016 (1.3386 - 1.3392)
Valve lifter clearance	0.010 - 0.036 (0.0004 - 0.0014)

VALVE CLEARANCE

Unit: mm (in)

Items	Cold	Hot* (reference data)
Intake	0.26 - 0.34 (0.010 - 0.013)	0.304 - 0.416 (0.012 - 0.016)
Exhaust	0.29 - 0.37 (0.011 - 0.015)	0.308 - 0.432 (0.012 - 0.017)

*: Approximately 80°C (176°F)

AVAILABLE VALVE LIFTER

Unit: mm (in)

Identification (stamped) mark	Thickness
788	7.88 (0.3102)
790	7.90 (0.3110)
792	7.92 (0.3118)
794	7.94 (0.3126)
796	7.96 (0.3134)
798	7.98 (0.3142)
800	8.00 (0.3150)
802	8.02 (0.3157)
804	8.04 (0.3165)
806	8.06 (0.3173)
808	8.08 (0.3181)
810	8.10 (0.3189)
812	8.12 (0.3197)
814	8.14 (0.3205)
816	8.16 (0.3213)
818	8.18 (0.3220)
820	8.20 (0.3228)
822	8.22 (0.3236)
824	8.24 (0.3244)
826	8.26 (0.3252)
828	8.28 (0.3260)
830	8.30 (0.3268)
832	8.32 (0.3276)
834	8.34 (0.3283)
836	8.36 (0.3291)
838	8.38 (0.3299)

SERVICE DATA AND SPECIFICATIONS (SDS)

< SERVICE DATA AND SPECIFICATIONS (SDS)

[VQ35HR]

Identification (stamped) mark	Thickness
840	8.40 (0.3307)

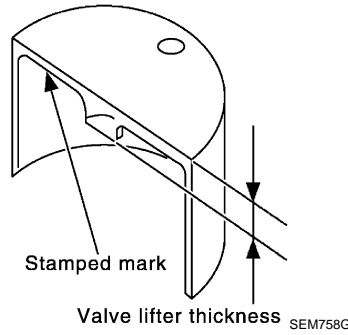

Cylinder Head

INFOID:000000003887402

CYLINDER HEAD

Unit: mm (in)

Items	Standard	Limit
Head surface distortion	Less than 0.03 (0.0012)	0.1 (0.004)
Normal cylinder head height "H"	126.3 - 126.5 (4.97 - 4.98)	—

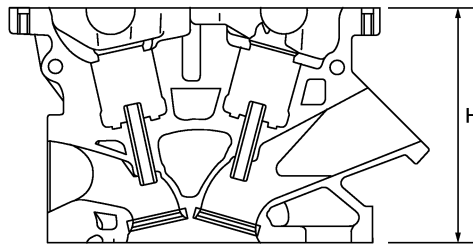

PBIC0924E

VALVE DIMENSIONS

Unit: mm (in)

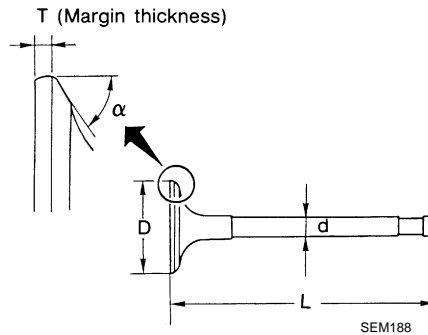

Valve head diameter "D"	Intake	36.6 - 36.9 (1.441 - 1.453)
	Exhaust	30.2 - 30.5 (1.189 - 1.201)
Valve length "L"	Intake	97.13 (3.8240)
	Exhaust	94.67 (3.7272)
Valve stem diameter "d"	Intake	5.965 - 5.980 (0.2348 - 0.2354)
	Exhaust	5.962 - 5.970 (0.2347 - 0.2350)

SERVICE DATA AND SPECIFICATIONS (SDS)

< SERVICE DATA AND SPECIFICATIONS (SDS)

[VQ35HR]

Valve seat angle "α"	Intake	45°15' - 45°45'
	Exhaust	
Valve margin "T"	Intake	1.1 (0.043)
	Exhaust	1.3 (0.051)
Valve margin "T" limit		0.5 (0.020)
Valve stem end surface grinding limit		0.2 (0.008)

VALVE GUIDE

Unit: mm (in)

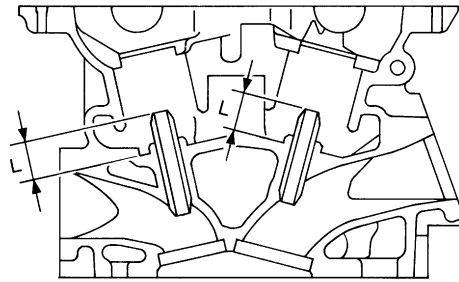

SEM950E

Items	Standard	Oversize (Service) [0.2 (0.008)]
Valve guide	Outer diameter	10.023 - 10.034 (0.3946 - 0.3950)
	Inner diameter (Finished size)	6.000 - 6.018 (0.2362 - 0.2369)
Cylinder head valve guide hole diameter	9.975 - 9.996 (0.3927 - 0.3935)	10.175 - 10.196 (0.4006 - 0.4014)
Interference fit of valve guide	0.027 - 0.059 (0.0011 - 0.0023)	
Items	Standard	Limit
Valve guide clearance	Intake	0.020 - 0.053 (0.0008 - 0.0021)
	Exhaust	0.030 - 0.056 (0.0012 - 0.0022)
Projection length "L"	12.6 - 12.8 (0.496 - 0.504)	

VALVE SEAT

Unit: mm (in)

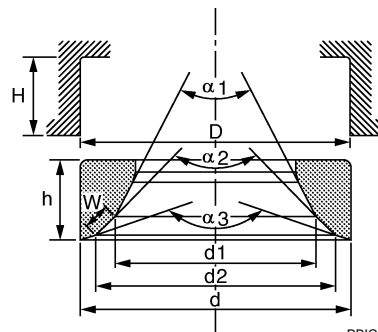

PBIC2745E

Items	Standard	Oversize (Service) [0.5 (0.02)]
Cylinder head seat recess diameter "D"	Intake	38.000 - 38.016 (1.4961 - 1.4967)
	Exhaust	31.600 - 31.616 (1.2441 - 1.2447)
Valve seat outer diameter "d"	Intake	38.097 - 38.113 (1.4999 - 1.5005)
	Exhaust	31.680 - 31.696 (1.2472 - 1.2479)
Valve seat interference fit	Intake	0.081 - 0.113 (0.0032 - 0.0044)
	Exhaust	0.064 - 0.096 (0.0025 - 0.0038)

SERVICE DATA AND SPECIFICATIONS (SDS)

< SERVICE DATA AND SPECIFICATIONS (SDS)

[VQ35HR]

Diameter "d1"*1	Intake	34.6 (1.362)	
	Exhaust	27.7 (1.091)	
Diameter "d2"*2	Intake	35.9 - 36.4 (1.413 - 1.433)	
	Exhaust	29.3 - 29.8 (1.154 - 1.173)	
Angle "α1"	Intake	60°	
	Exhaust	60°	
Angle "α2"	Intake	88°45' - 90°15'	
	Exhaust	88°45' - 90°15'	
Angle "α3"	Intake	120°	
	Exhaust	120°	
Contacting width "W"*3	Intake	1.0 - 1.4 (0.039 - 0.055)	
	Exhaust	1.2 - 1.6 (0.047 - 0.063)	
Height "h"	Intake	5.9 - 6.0 (0.232 - 0.236)	5.05 - 5.15 (0.1988 - 0.2028)
	Exhaust	5.9 - 6.0 (0.232 - 0.236)	4.95 - 5.05 (0.1949 - 0.1988)
Depth "H"		6.0 (0.236)	

*1: Diameter made by intersection point of conic angles "α1" and "α2"

*2: Diameter made by intersection point of conic angles "α2" and "α3"

*3: Machining data

VALVE SPRING

Items	Standard
Free height	43.85 mm (1.7264 in)
Installation height	37.00 mm (1.4567 in)
Installation load	166 - 188 N (16.9 - 19.2 kg, 37 - 42 lb)
Height during valve open	26.8 mm (1.055 in)
Load with valve open	502 - 566 N (51.2 - 57.7 kg, 113 - 127 lb)
Squareness	1.9 mm (0.075 in)

Cylinder Block

INFOID:000000003887403

CYLINDER BLOCK

Unit: mm (in)

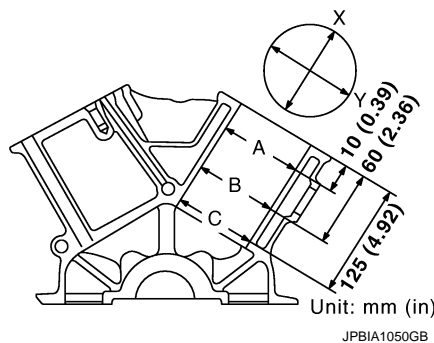

Surface flatness	Standard	Less than 0.03 (0.0012)
	Limit	0.1 (0.004)
Main bearing housing inner diameter	Standard	69.993 - 70.017 (2.7556 - 2.7566)

SERVICE DATA AND SPECIFICATIONS (SDS)

< SERVICE DATA AND SPECIFICATIONS (SDS)

[VQ35HR]

Cylinder bore	Inner diameter	Standard	Grade No. 1	95.500 - 95.510 (3.7598 - 3.7602)
			Grade No. 2	95.510 - 95.520 (3.7602 - 3.7606)
			Grade No. 3	95.520 - 95.530 (3.7606 - 3.7610)
		Wear limit	0.2 (0.008)	
Out-of-round			0.015 (0.0006)	
Taper			0.010 (0.0004)	
Main bearing housing inner diameter grade (Without bearing)			Grade No. A	69.993 - 69.994 (2.7556 - 2.7557)
			Grade No. B	69.994 - 69.995 (2.7557 - 2.7557)
			Grade No. C	69.995 - 69.996 (2.7557 - 2.7557)
			Grade No. D	69.996 - 69.997 (2.7557 - 2.7558)
			Grade No. E	69.997 - 69.998 (2.7558 - 2.7558)
			Grade No. F	69.998 - 69.999 (2.7558 - 2.7559)
			Grade No. G	69.999 - 70.000 (2.7559 - 2.7559)
			Grade No. H	70.000 - 70.001 (2.7559 - 2.7559)
			Grade No. J	70.001 - 70.002 (2.7559 - 2.7560)
			Grade No. K	70.002 - 70.003 (2.7560 - 2.7560)
			Grade No. L	70.003 - 70.004 (2.7560 - 2.7561)
			Grade No. M	70.004 - 70.005 (2.7561 - 2.7561)
			Grade No. N	70.005 - 70.006 (2.7561 - 2.7561)
			Grade No. P	70.006 - 70.007 (2.7561 - 2.7562)
			Grade No. R	70.007 - 70.008 (2.7562 - 2.7562)
			Grade No. S	70.008 - 70.009 (2.7562 - 2.7563)
			Grade No. T	70.009 - 70.010 (2.7563 - 2.7563)
Grade No. U	70.010 - 70.011 (2.7563 - 2.7563)			
Grade No. V	70.011 - 70.012 (2.7563 - 2.7564)			
Grade No. W	70.012 - 70.013 (2.7564 - 2.7564)			
Grade No. X	70.013 - 70.014 (2.7564 - 2.7565)			
Grade No. Y	70.014 - 70.015 (2.7565 - 2.7565)			
Grade No. 4	70.015 - 70.016 (2.7565 - 2.7565)			
Grade No. 7	70.016 - 70.017 (2.7565 - 2.7566)			
Difference in inner diameter between cylinders	Standard		Less than 0.03 (0.0012)	

AVAILABLE PISTON

Unit: mm (in)

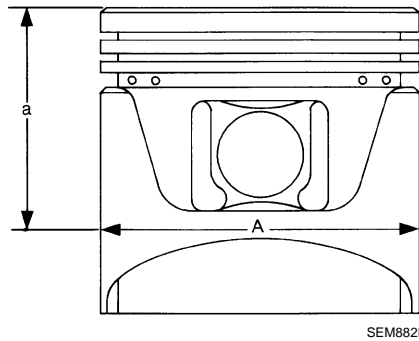

Items	Standard	Oversize (Service) [0.2 (0.008)]
Piston skirt diameter "A"	Grade No. 1	95.480 - 95.490 (3.7590 - 3.7594)
	Grade No. 2	95.490 - 95.500 (3.7594 - 3.7598)
	Grade No. 3	95.500 - 95.510 (3.7598 - 3.7602)
	Service	—
		95.680 - 95.710 (3.7669 - 3.7681)
Items	Standard	Limit
"a" dimension	38.8 (1.528)	—
Piston pin hole diameter	Grade No. 0	21.993 - 21.999 (0.8659 - 0.8661)
	Grade No. 1	21.999 - 22.005 (0.8661 - 0.8663)
Piston to cylinder bore clearance	0.010 - 0.030 (0.0004 - 0.0012)	0.08 (0.0031)

SERVICE DATA AND SPECIFICATIONS (SDS)

< SERVICE DATA AND SPECIFICATIONS (SDS)

[VQ35HR]

PISTON RING

Unit: mm (in)

Items		Standard	Limit
Side clearance	Top	0.040 - 0.080 (0.0016 - 0.0031)	0.11 (0.0043)
	2nd	0.030 - 0.070 (0.0012 - 0.0028)	0.10 (0.0039)
	Oil ring	0.055 - 0.155 (0.0022 - 0.0061)	—
End gap	Top	0.23 - 0.33 (0.0091 - 0.0130)	0.42 (0.0165)
	2nd	0.33 - 0.48 (0.0130 - 0.0189)	0.57 (0.0224)
	Oil (rail ring)	0.17 - 0.47 (0.0067 - 0.0185)	0.63 (0.0248)

PISTON PIN

Unit: mm (in)

Items		Standard	Limit
Piston pin outer diameter	Grade No. 0	21.989 - 21.995 (0.8657 - 0.8659)	—
	Grade No. 1	21.995 - 22.001 (0.8659 - 0.8662)	—
Piston to piston pin oil clearance		0.002 - 0.006 (0.0001 - 0.0002)	—
Connecting rod bushing oil clearance		0.005 - 0.017 (0.0002 - 0.0007)	0.030 (0.0012)

CONNECTING ROD

Unit: mm (in)

Items		Standard	Limit
Center distance		144.15 - 144.25 (5.68 - 5.68)	—
Bend [per 100 (3.94)]		—	0.15 (0.0059)
Torsion [per 100 (3.94)]		—	0.30 (0.0118)
Connecting rod bushing inner diameter*	Grade No. 0	22.000 - 22.006 (0.8661 - 0.8664)	—
	Grade No. 1	22.006 - 22.012 (0.8664 - 0.8666)	—
Connecting rod big end diameter (Without bearing)	Grade No. A	57.000 - 57.001 (2.2441 - 2.2441)	—
	Grade No. B	57.001 - 57.002 (2.2441 - 2.2442)	—
	Grade No. C	57.002 - 57.003 (2.2442 - 2.2442)	—
	Grade No. D	57.003 - 57.004 (2.2442 - 2.2442)	—
	Grade No. E	57.004 - 57.005 (2.2442 - 2.2443)	—
	Grade No. F	57.005 - 57.006 (2.2443 - 2.2443)	—
	Grade No. G	57.006 - 57.007 (2.2443 - 2.2444)	—
	Grade No. H	57.007 - 57.008 (2.2444 - 2.2444)	—
	Grade No. J	57.008 - 57.009 (2.2444 - 2.2444)	—
	Grade No. K	57.009 - 57.010 (2.2444 - 2.2445)	—
	Grade No. L	57.010 - 57.011 (2.2445 - 2.2445)	—
	Grade No. M	57.011 - 57.012 (2.2445 - 2.2446)	—
	Grade No. N	57.012 - 57.013 (2.2446 - 2.2446)	—
	Side clearance		0.20 - 0.35 (0.0079 - 0.0138)

*: After installing in connecting rod

CRANKSHAFT

SERVICE DATA AND SPECIFICATIONS (SDS)

< SERVICE DATA AND SPECIFICATIONS (SDS)

[VQ35HR]

Unit: mm (in)

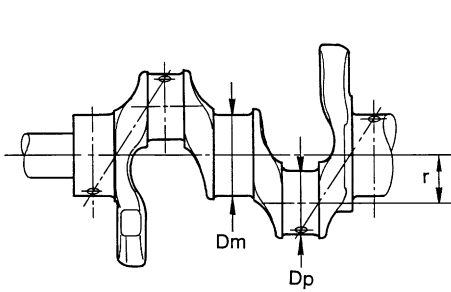

SEM645

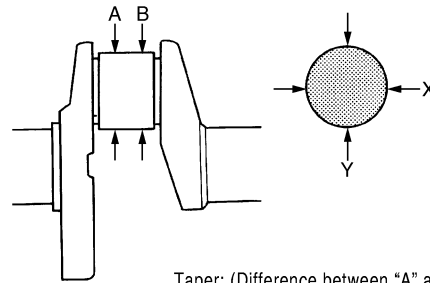

Taper: (Difference between "A" and "B")
Out-of-round: (Difference between "X" and "Y")

SBIA0535E

Main journal diameter. "Dm" grade	Standard	Grade No. A	64.975 - 64.974 (2.5581 - 2.5580)		
		Grade No. B	64.974 - 64.973 (2.5580 - 2.5580)		
		Grade No. C	64.973 - 64.972 (2.5580 - 2.5579)		
		Grade No. D	64.972 - 64.971 (2.5579 - 2.5579)		
		Grade No. E	64.971 - 64.970 (2.5579 - 2.5579)		
		Grade No. F	64.970 - 64.969 (2.5579 - 2.5578)		
		Grade No. G	64.969 - 64.968 (2.5578 - 2.5578)		
		Grade No. H	64.968 - 64.967 (2.5578 - 2.5578)		
		Grade No. J	64.967 - 64.966 (2.5578 - 2.5577)		
		Grade No. K	64.966 - 64.965 (2.5577 - 2.5577)		
		Grade No. L	64.965 - 64.964 (2.5577 - 2.5576)		
		Grade No. M	64.964 - 64.963 (2.5576 - 2.5576)		
		Grade No. N	64.963 - 64.962 (2.5576 - 2.5576)		
		Grade No. P	64.962 - 64.961 (2.5576 - 2.5575)		
		Grade No. R	64.961 - 64.960 (2.5575 - 2.5575)		
		Grade No. S	64.960 - 64.959 (2.5575 - 2.5574)		
		Grade No. T	64.959 - 64.958 (2.5574 - 2.5574)		
		Grade No. U	64.958 - 64.957 (2.5574 - 2.5574)		
		Pin journal diameter. "Dp" grade	Standard	Grade No. A	53.974 - 53.973 (2.1250 - 2.1249)
				Grade No. B	53.973 - 53.972 (2.1249 - 2.1249)
Grade No. C	53.972 - 53.971 (2.1249 - 2.1248)				
Grade No. D	53.971 - 53.970 (2.1248 - 2.1248)				
Grade No. E	53.970 - 53.969 (2.1248 - 2.1248)				
Grade No. F	53.969 - 53.968 (2.1248 - 2.1247)				
Grade No. G	53.968 - 53.967 (2.1247 - 2.1247)				
Grade No. H	53.967 - 53.966 (2.1247 - 2.1246)				
Grade No. J	53.966 - 53.965 (2.1246 - 2.1246)				
Grade No. K	53.965 - 53.964 (2.1246 - 2.1246)				
Grade No. L	53.964 - 53.963 (2.1246 - 2.1245)				
Grade No. M	53.963 - 53.962 (2.1245 - 2.1245)				
Grade No. N	53.962 - 53.961 (2.1245 - 2.1244)				
Grade No. P	53.961 - 53.960 (2.1244 - 2.1244)				
Grade No. R	53.960 - 53.959 (2.1244 - 2.1244)				
Grade No. S	53.959 - 53.958 (2.1244 - 2.1243)				
Grade No. T	53.958 - 53.957 (2.1243 - 2.1243)				
Grade No. U	53.957 - 53.956 (2.1243 - 2.1242)				
Center distance "r"		40.66 - 40.74 (1.6008 - 1.6039)			

SERVICE DATA AND SPECIFICATIONS (SDS)

< SERVICE DATA AND SPECIFICATIONS (SDS)

[VQ35HR]

Taper (Difference between "A" and "B")	Limit	0.0025 (0.0001)
Out-of-round (Difference between "X" and "Y")		0.0025 (0.0001)
Crankshaft runout [TIR*]	Standard	Less than 0.05 (0.0020)
	Limit	0.10 (0.0039)
Crankshaft end play	Standard	0.10 - 0.25 (0.0039 - 0.0098)
	Limit	0.30 (0.0118)

*: Total indicator reading

Main Bearing

INFOID:000000003887404

MAIN BEARING

Unit: mm (in)

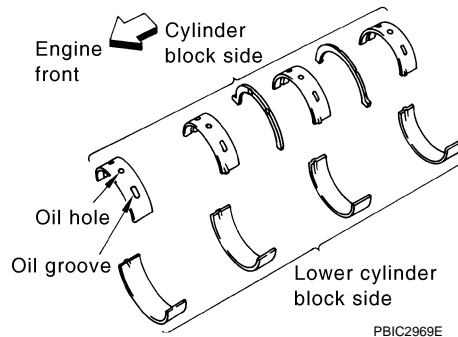

Grade number	Thickness	Width	Identification color	Remarks		
0	2.500 - 2.503 (0.0984 - 0.0985)	19.9 - 20.1 (0.783 - 0.791)	Black	Grade is the same for upper and lower bearings.		
1	2.503 - 2.506 (0.0985 - 0.0987)		Brown			
2	2.506 - 2.509 (0.0987 - 0.0988)		Green			
3	2.509 - 2.512 (0.0988 - 0.0989)		Yellow			
4	2.512 - 2.515 (0.0989 - 0.0990)		Blue			
5	2.515 - 2.518 (0.0990 - 0.0991)		Pink			
6	2.518 - 2.521 (0.0991 - 0.0993)		Purple			
7	2.521 - 2.524 (0.0993 - 0.0994)		White			
01	UPR		2.503 - 2.506 (0.0985 - 0.0987)		Brown	Grade and color are different for upper and lower bearings.
	LWR		2.500 - 2.503 (0.0984 - 0.0985)		Black	
12	UPR		2.506 - 2.509 (0.0987 - 0.0988)		Green	
	LWR		2.503 - 2.506 (0.0985 - 0.0987)		Brown	
23	UPR		2.509 - 2.512 (0.0988 - 0.0989)		Yellow	
	LWR		2.506 - 2.509 (0.0987 - 0.0988)		Green	
34	UPR	2.512 - 2.515 (0.0989 - 0.0990)	Blue			
	LWR	2.509 - 2.512 (0.0988 - 0.0989)	Yellow			
45	UPR	2.515 - 2.518 (0.0990 - 0.0991)	Pink			
	LWR	2.512 - 2.515 (0.0989 - 0.0990)	Blue			
56	UPR	2.518 - 2.521 (0.0991 - 0.0993)	Purple			
	LWR	2.515 - 2.518 (0.0990 - 0.0991)	Pink			
67	UPR	2.521 - 2.524 (0.0993 - 0.0994)	White			
	LWR	2.518 - 2.521 (0.0991 - 0.0993)	Purple			

UNDERSIZE

SERVICE DATA AND SPECIFICATIONS (SDS)

< SERVICE DATA AND SPECIFICATIONS (SDS)

[VQ35HR]

Unit: mm (in)

Items	Thickness	Main journal diameter
0.25 (0.0098)	2.633 - 2.641 (0.1037 - 0.1040)	Grind so that bearing clearance is the specified value.

MAIN BEARING OIL CLEARANCE

Unit: mm (in)

Items	Standard	Limit
Main bearing oil clearance	0.035 - 0.045 (0.0014 - 0.0018)*	0.065 (0.0026)

*: Actual clearance

Connecting Rod Bearing

INFOID:000000003887405

CONNECTING ROD BEARING

Unit: mm (in)

Grade number	Thickness	Identification color (mark)
0	1.497 - 1.500 (0.0589 - 0.0591)	Black
1	1.500 - 1.503 (0.0591 - 0.0592)	Brown
2	1.503 - 1.506 (0.0592 - 0.0593)	Green
3	1.506 - 1.509 (0.0593 - 0.0594)	Yellow
4	1.509 - 1.512 (0.0594 - 0.0595)	Blue

UNDERSIZE

Unit: mm (in)

Items	Thickness	Crank pin journal diameter
0.25 (0.0098)	1.626 - 1.634 (0.0640 - 0.0643)	Grind so that bearing clearance is the specified value.

CONNECTING ROD BEARING OIL CLEARANCE

Unit: mm (in)

Items	Standard	Limit
Connecting rod bearing oil clearance	0.040 - 0.053 (0.0016 - 0.0021)*	0.070 (0.0028)

*: Actual clearance

SYMPTOM DIAGNOSIS

NOISE, VIBRATION AND HARSHNESS (NVH) TROUBLESHOOTING

NVH Troubleshooting - Engine Noise

INFOID:000000003733386

A

EM

C

D

E

F

G

H

I

J

K

L

M

N

O

P

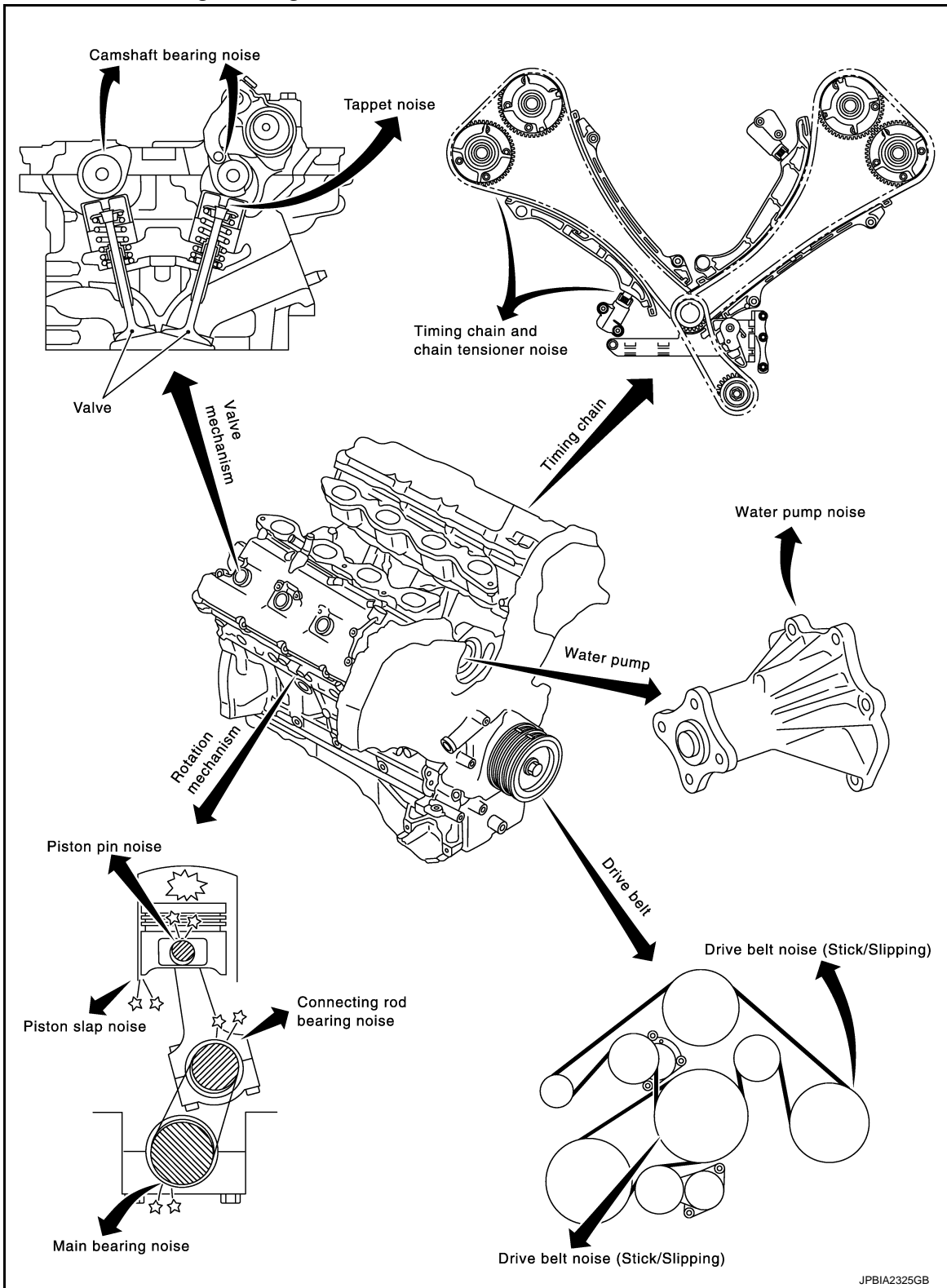

Use the Chart Below to Help You Find the Cause of the Symptom

INFOID:000000003733387

1. Locate the area where noise occurs.

NOISE, VIBRATION AND HARSHNESS (NVH) TROUBLESHOOTING

< SYMPTOM DIAGNOSIS >

[VK50VE]

2. Confirm the type of noise.
3. Specify the operating condition of the engine.
4. Check specified noise source.

If necessary, repair or replace these parts.

Location of noise	Type of noise	Operating condition of engine						Source of noise	Check item	Reference page
		Before warm-up	After warm-up	When starting	When idling	When racing	While driving			
Top of engine Rocker cover Cylinder head	Ticking or clicking	C	A	—	A	B	—	Tappet noise	Valve clearance	EM-169
	Rattle	C	A	—	A	B	C	Camshaft bearing noise	Camshaft runout Camshaft journal oil clearance	EM-236
Crankshaft pulley Cylinder block (Side of engine) Oil pan	Slap or knock	—	A	—	B	B	—	Piston pin noise	Piston to piston pin oil clearance Connecting rod bushing oil clearance	EM-265
	Slap or rap	A	—	—	B	B	A	Piston slap noise	Piston to cylinder bore clearance Piston ring side clearance Piston ring end gap Connecting rod bend and torsion	EM-265
	Knock	A	B	C	B	B	B	Connecting rod bearing noise	Connecting rod bushing oil clearance Connecting rod bearing oil clearance	EM-265
	Knock	A	B	—	A	B	C	Main bearing noise	Main bearing oil clearance Crankshaft runout	EM-265
Front of engine Timing chain case	Tapping or ticking	A	A	—	B	B	B	Timing chain and timing chain tensioner noise	Timing chain cracks and wears Timing chain tensioner operation	EM-225
Front of engine	Squeaking or fizzing	A	B	—	B	—	C	Drive belts (Sticking or slipping)	Drive belts deflection	EM-164
	Creaking	A	B	A	B	A	B	Drive belts (Slipping)	Idler pulley bearing operation	
	Squall Creak	A	B	—	B	A	B	Water pump noise	Water pump operation	CO-45

A: Closely related B: Related C: Sometimes related —: Not related

PRECAUTION

PRECAUTIONS

Precaution for Procedure without Cowl Top Cover

INFOID:000000003901618

When performing the procedure after removing cowl top cover, cover the lower end of windshield with urethane, etc.

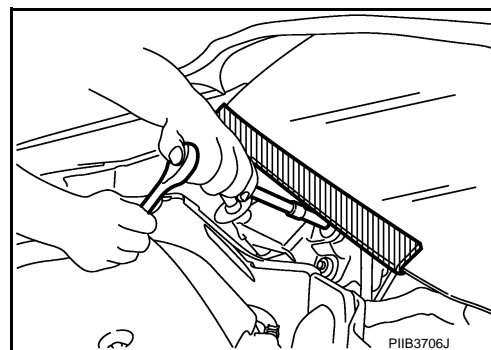

Precaution for Supplemental Restraint System (SRS) "AIR BAG" and "SEAT BELT PRE-TENSIONER"

INFOID:000000003901616

The Supplemental Restraint System such as "AIR BAG" and "SEAT BELT PRE-TENSIONER", used along with a front seat belt, helps to reduce the risk or severity of injury to the driver and front passenger for certain types of collision. This system includes seat belt switch inputs and dual stage front air bag modules. The SRS system uses the seat belt switches to determine the front air bag deployment, and may only deploy one front air bag, depending on the severity of a collision and whether the front occupants are belted or unbelted. Information necessary to service the system safely is included in the "SRS AIR BAG" and "SEAT BELT" of this Service Manual.

WARNING:

- To avoid rendering the SRS inoperative, which could increase the risk of personal injury or death in the event of a collision which would result in air bag inflation, all maintenance must be performed by an authorized NISSAN/INFINITI dealer.
- Improper maintenance, including incorrect removal and installation of the SRS, can lead to personal injury caused by unintentional activation of the system. For removal of Spiral Cable and Air Bag Module, see the "SRS AIR BAG".
- Do not use electrical test equipment on any circuit related to the SRS unless instructed to in this Service Manual. SRS wiring harnesses can be identified by yellow and/or orange harnesses or harness connectors.

PRECAUTIONS WHEN USING POWER TOOLS (AIR OR ELECTRIC) AND HAMMERS

WARNING:

- When working near the Air Bag Diagnosis Sensor Unit or other Air Bag System sensors with the ignition ON or engine running, DO NOT use air or electric power tools or strike near the sensor(s) with a hammer. Heavy vibration could activate the sensor(s) and deploy the air bag(s), possibly causing serious injury.
- When using air or electric power tools or hammers, always switch the ignition OFF, disconnect the battery, and wait at least 3 minutes before performing any service.

Precaution Necessary for Steering Wheel Rotation after Battery Disconnect

INFOID:000000003901617

NOTE:

- Before removing and installing any control units, first turn the push-button ignition switch to the LOCK position, then disconnect both battery cables.
- After finishing work, confirm that all control unit connectors are connected properly, then re-connect both battery cables.
- Always use CONSULT-III to perform self-diagnosis as a part of each function inspection after finishing work. If a DTC is detected, perform trouble diagnosis according to self-diagnosis results.

This vehicle is equipped with a push-button ignition switch and a steering lock unit. If the battery is disconnected or discharged, the steering wheel will lock and cannot be turned.

A
EM

C
D
E

F

G
H

I
J

K
L

M
N

O
P

PRECAUTIONS

[VK50VE]

< PRECAUTION >

If turning the steering wheel is required with the battery disconnected or discharged, follow the procedure below before starting the repair operation.

OPERATION PROCEDURE

1. Connect both battery cables.

NOTE:

Supply power using jumper cables if battery is discharged.

2. Turn the push-button ignition switch to ACC position.
(At this time, the steering lock will be released.)
3. Disconnect both battery cables. The steering lock will remain released with both battery cables disconnected and the steering wheel can be turned.
4. Perform the necessary repair operation.
5. When the repair work is completed, re-connect both battery cables. With the brake pedal released, turn the push-button ignition switch from ACC position to ON position, then to LOCK position. (The steering wheel will lock when the push-button ignition switch is turned to LOCK position.)
6. Perform self-diagnosis check of all control units using CONSULT-III.

Precaution for Drain Engine Coolant and Engine Oil

INFOID:000000003733478

Drain engine coolant and engine oil when engine is cooled.

Precaution for Disconnecting Fuel Piping

INFOID:000000003733479

- Before starting work, check no fire or spark producing items are in the work area.
- Release fuel pressure before disconnecting and disassembly.
- After disconnecting pipes, plug openings to stop fuel leakage.

Precaution for Removal and Disassembly

INFOID:000000003733480

- When instructed to use SST, use specified tools. Always be careful to work safely, avoid forceful or uninstructed operations.
- Exercise maximum care to avoid damage to mating or sliding surfaces.
- Cover openings of engine system with tape or the equivalent, if necessary, to seal out foreign materials.
- Mark and arrange disassembly parts in an organized way for easy troubleshooting and assembly.
- When loosening nuts and bolts, as a basic rule, start with the one furthest outside, then the one diagonally opposite, and so on. If the order of loosening is specified, do exactly as specified. Power tools may be used where noted in the step.

Precaution for Inspection, Repair and Replacement

INFOID:000000003733481

Before repairing or replacing, thoroughly inspect parts. Inspect new replacement parts in the same way, and replace if necessary.

Precaution for Assembly and Installation

INFOID:000000003733482

- Use torque wrench to tighten bolts or nuts to specification.
- When tightening nuts and bolts, as a basic rule, equally tighten in several different steps starting with the ones in center, then ones on inside and outside diagonally in this order. If the order of tightening is specified, do exactly as specified.
- Replace with new gasket, packing, oil seal or O-ring.
- Thoroughly wash, clean, and air-blow each part. Carefully check engine oil or engine coolant passages for any restriction and blockage.
- Dowel pins are used for several parts alignment. When replacing and reassembling parts with dowel pins, check that dowel pins are installed in the original position.
- Avoid damaging sliding or mating surfaces. Completely remove foreign materials such as cloth lint or dust. Before assembly, oil sliding surfaces well.
- Release air within route when refilling after draining engine coolant.
- After repairing, start engine and increase engine speed to check engine coolant, fuel, engine oil, and exhaust gases for leakage.

PRECAUTIONS

< PRECAUTION >

[VK50VE]

Parts Requiring Angle Tightening

INFOID:000000003733483

- Use angle wrench [SST: KV10112100 (BT8653-A)] for the final tightening of the following engine parts:
 - Cylinder head bolts
 - Main bearing cap bolts
 - Main bearing cap sub bolts
 - Connecting rod cap bolts
 - Crankshaft pulley bolt (No angle wrench is required as the bolt flange is provided with notches for angle tightening)
- Ensure thread and seat surfaces are clean and coated with engine oil.

Precaution for Liquid Gasket

INFOID:000000003733484

REMOVAL OF LIQUID GASKET SEALING

- After removing mounting nuts and bolts, separate the mating surface using the seal cutter [SST:KV10111100 (J-37228)] (A) and remove old liquid gasket sealing.

CAUTION:

Be careful not to damage the mating surfaces.

- Tap the seal cutter to insert it (B), and then slide it (C) by tapping on the side as shown in the figure.
- In areas where the seal cutter is difficult to use, lightly tap the parts using a plastic hammer to remove it.

CAUTION:

If for some unavoidable reason a tool such as a screwdriver is used, be careful not to damage the mating surfaces.

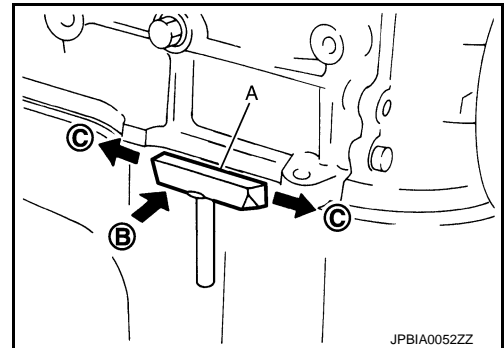

LIQUID GASKET APPLICATION PROCEDURE

1. Using a scraper (A), remove old liquid gasket adhering to the liquid gasket application surface and the mating surface.
 - Remove liquid gasket completely from the groove of the liquid gasket application surface, mounting bolts and bolt holes.
2. Wipe the liquid gasket application surface and the mating surface with white gasoline (lighting and heating use) to remove adhering moisture, grease and foreign materials.

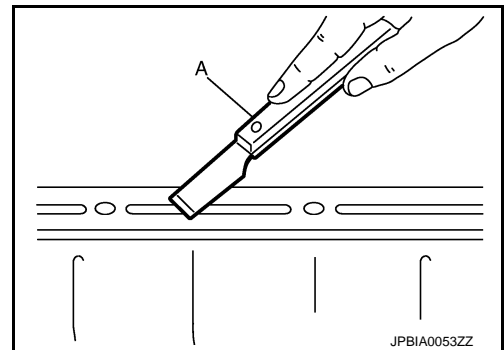

3. Attach liquid gasket tube to the tube presser (commercial service tool).

Use Genuine RTV Silicone Sealant or an equivalent. Refer to GI-15, "Recommended Chemical Products and Sealants".
4. Apply liquid gasket without gaps to the specified location according to the specified dimensions.
 - If there is a groove for liquid gasket application, apply liquid gasket to the groove.

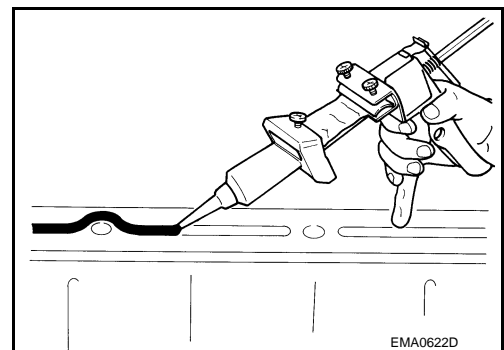

PRECAUTIONS

[VK50VE]

< PRECAUTION >

- As for bolt holes (B), normally apply liquid gasket inside the holes. Occasionally, it should be applied outside the holes. Check to read the text of this manual.

A : Groove

↩ : Inside

- Within 5 minutes of liquid gasket application, install the mating component.
- If liquid gasket protrudes, wipe it off immediately.
- Do not retighten mounting bolts or nuts after the installation.
- After 30 minutes or more have passed from the installation, fill engine oil and engine coolant.

CAUTION:

If there are specific instructions in this manual, observe them.

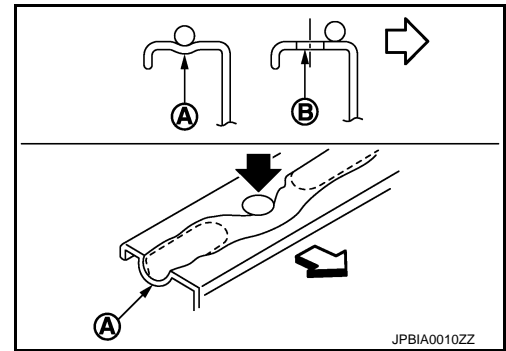

Definitions of Bank Names

INFOID:000000003739334

- In this manual, each bank name is defined as per the following:

A : Bank 2 (The conventional right bank)

B : Bank 1 (The conventional left bank)

↩ : Engine front

- For cylinder numbers and bank layout, refer to the figure.

Bank 1 : The bank side including cylinder No. 1 (odd-numbered cylinder side)

Bank 2 : The other bank side of the above (even-numbered cylinder side)

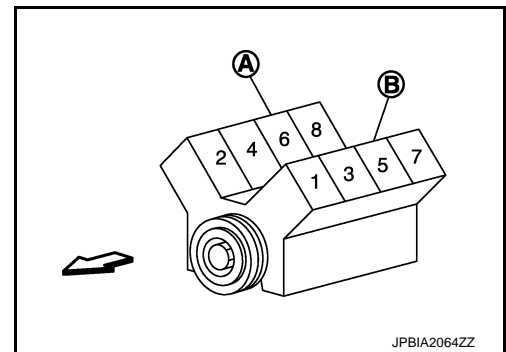

PREPARATION

< PREPARATION >

[VK50VE]

PREPARATION

PREPARATION

Special Service Tool

INFOID:000000003733473

A

EM

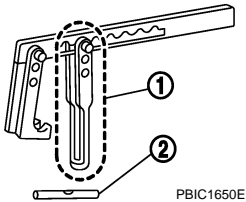
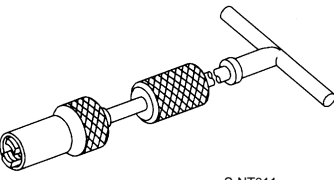
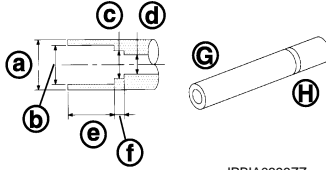
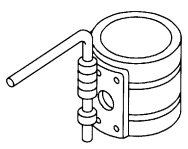
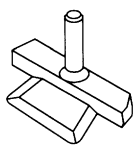
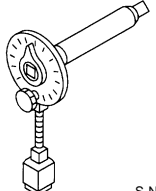
Tool number (Kent-Moore No.) Tool name	Description
KV10116200 (J-26336-A) Valve spring compressor 1. KV10115900 (J-26336-20) Attachment 2. KV10109220 (—) Adapter	 Disassembling valve mechanism Part (1) is a component of KV10116200 (J26336-A), but part (2) is not so.
KV10107902 (J-38959) Valve oil seal puller	 Removing valve oil seal
KV10115600 (J-38958) Valve oil seal drift	 Installing valve oil seal Use side A (G) a: 20 (0.79) dia. d: 8 (0.31) dia. b: 13 (0.51) dia. e: 10.7 (0.421) c: 10.3 (0.406) dia. f: 5 (0.20) H: Side B Unit: mm (in)
EM03470000 (J-8037) Piston ring compressor	 Installing piston assembly into cylinder bore
KV10111100 (J-37228) Seal cutter	 Removing steel oil pan and front cover
KV10112100 (BT8653-A) Angle wrench	 Tightening bolts for bearing cap, cylinder head, etc.

C

D

E

F

G

H

I

J

K

L

M

N

O

P

PREPARATION

< PREPARATION >

[VK50VE]

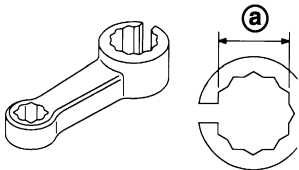
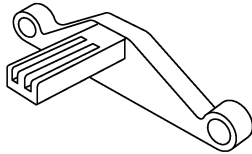
Tool number (Kent-Moore No.) Tool name	Description
KV10114400 (J-38365) Heated oxygen sensor wrench  <small>JPBIA0397ZZ</small>	Loosening or tightening air fuel ratio sensor 1 and heated oxygen sensor 2 a: 22 mm (0.87 in)
KV10119200 (J-49277) Ring gear stopper  <small>JPBIA0409ZZ</small>	Removing and installing crankshaft pulley
KV10119300 (—) Adapter and torque wrench assembly	Tightening rocker cover mounting bolts. (specified torque)

Commercial Service Tool

INFOID:000000003733474

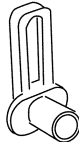
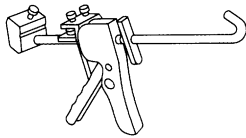
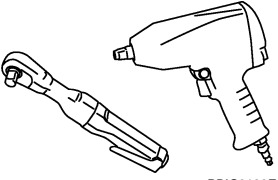
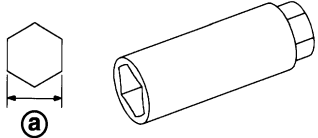
(Kent-Moore No.) Tool name	Description
(J-45488) Quick connector release  <small>PBIC0198E</small>	Removing fuel tube quick connectors in engine room
(—) Tube presser  <small>S-NT052</small>	Pressing the tube of liquid gasket
(—) Power tool  <small>PBIC0190E</small>	Loosening nuts and bolts
(—) Spark plug wrench  <small>JPBIA0399ZZ</small>	Removing and installing spark plug a: 14 mm (0.55 in)

PREPARATION

< PREPARATION >

[VK50VE]

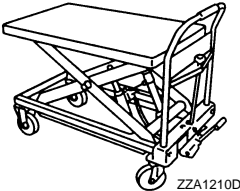
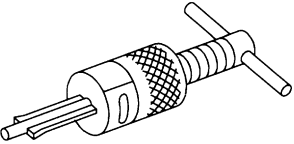
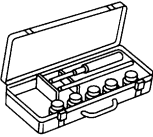
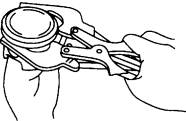
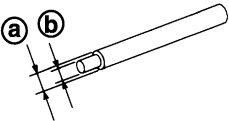
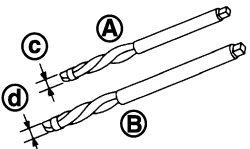
(Kent-Moore No.) Tool name	Description	A
(—) Manual lift table caddy	 <p style="text-align: center;">ZZA1210D</p>	EM
(—) Pilot bushing puller	 <p style="text-align: center;">NT045</p>	C D E
(—) Valve seat cutter set	 <p style="text-align: center;">S-NT048</p>	F G H
(—) Piston ring expander	 <p style="text-align: center;">S-NT030</p>	I J
(—) Valve guide drift	 <p style="text-align: center;">JPBIA0400ZZ</p>	K L
(—) Valve guide reamer	 <p style="text-align: center;">JPBIA0401ZZ</p>	M N O

P

PREPARATION

[VK50VE]

< PREPARATION >

(Kent-Moore No.) Tool name	Description
(J-43897-18) (J-43897-12) Oxygen sensor thread cleaner	Reconditioning the exhaust system threads before installing a new air fuel ratio sensor and heated oxygen sensor (Use with anti-seize lubricant shown below.) A: J-43897-18 [18 mm (0.71 in) dia.] for zirconia heated oxygen sensor and air fuel ratio sensor B: J-43897-12 [12 mm (0.47 in) dia.] for titania heated oxygen sensor C: Mating surface shave cylinder D: Flutes
(—) Anti-seize lubricant (Permatex 133AR or equivalent meeting MIL specification MIL-A-907)	Lubricating oxygen sensor thread cleaning tool when reconditioning exhaust system threads
(—) Feeler gauge	Inspection valve clearance (use a curved-tip gauge)
(—) Compression gauge with flexible type adapter	Checking compression pressure

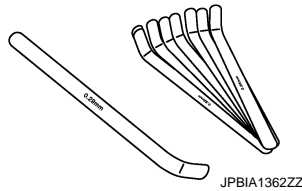
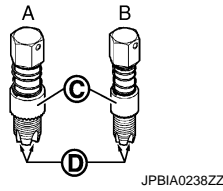

PERIODIC MAINTENANCE

DRIVE BELTS

Exploded View

INFOID:000000003733400

A

EM

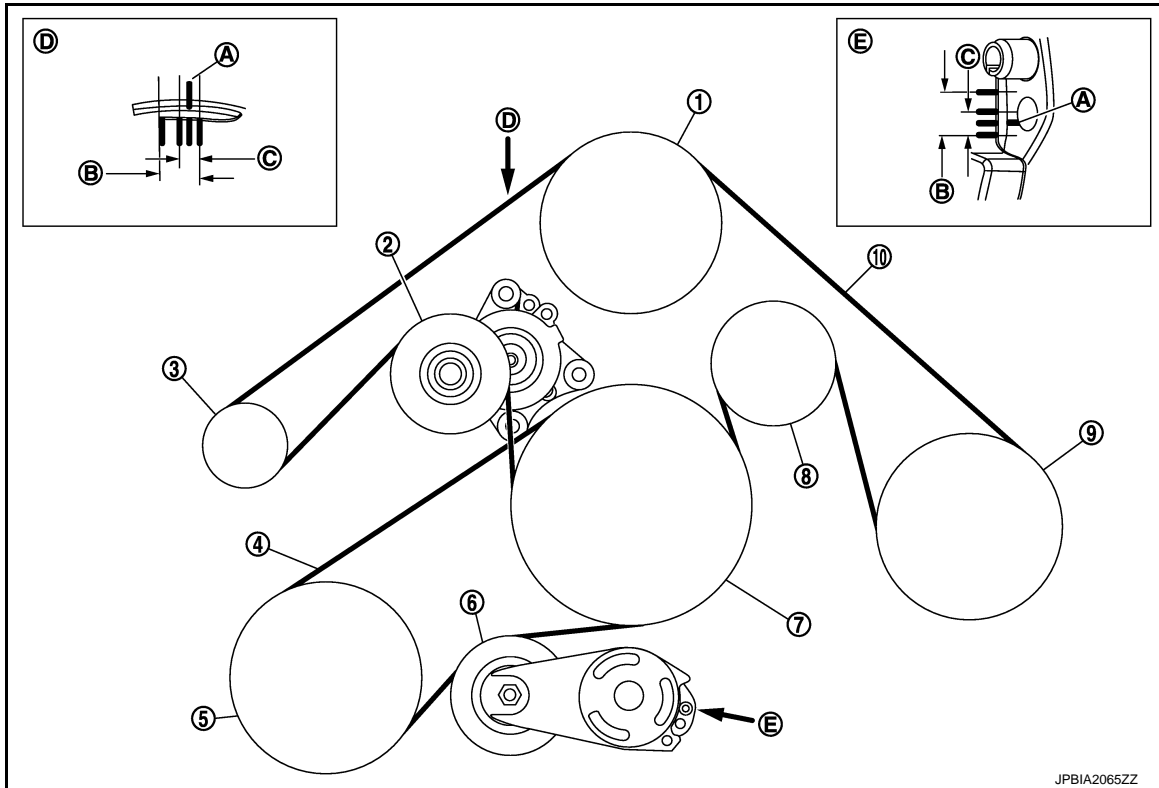

C

D

E

F

G

H

I

J

K

L

M

N

O

P

- | | | |
|--|--|--|
| 1. Water pump | 2. Auto-tensioner (for alternator, water pump and A/C compressor belt) | 3. Alternator |
| 4. Power steering oil pump belt | 5. Power steering oil pump | 6. Auto-tensioner (for power steering oil pump belt) |
| 7. Crankshaft pulley | 8. Idler pulley | 9. A/C compressor |
| 10. Alternator, water pump and A/C compressor belt | | |
| A. Indicator | B. Possible use range | C. Range when new drive belt is installed |
| D. View D | E. View E | |

Checking

INFOID:000000003733401

WARNING:

Be sure to perform the these steps when engine is stopped.

- Remove air duct (inlet) when inspecting alternator, water pump and A/C compressor belt.
- Remove engine undercover with power tool when inspecting power steering oil pump belt.
- Check that the indicator (A) (notch on fixed side) of each auto-tensioner is within the possible use range (B).

NOTE:

- Check the each auto-tensioners indication when the engine is cold.
- When new drive belts is installed, the indicator (notch on fixed side) should be within the range (C) in the figure.
- Visually check all drive belts for wear, damage or cracks.
- If the indicator (notch on fixed side) is out of the possible use range or drive belts are damaged, replace drive belts.

Tension Adjustment

INFOID:000000003733402

Refer to [EM-282, "Drive Belts"](#).

Removal and Installation

INFOID:000000003733403

REMOVAL

Alternator, Water Pump and A/C Compressor Belt

1. Remove air duct (inlet). Refer to [EM-177, "Exploded View"](#).
2. Remove reservoir tank. Refer to [CO-39, "Exploded View"](#).
3. With box wrench, and while securely holding the hexagonal part in pulley center of auto tensioner (1), move wrench handle in the direction of arrow (loosening direction of belt).

CAUTION:

- Never place hand in a location where pinching may occur if the holding tool accidentally comes off.
- Never loosen the hexagonal part in center of auto tensioner pulley (Never turn it clockwise). If turned clockwise, the complete auto tensioner must be replaced as a unit, including the pulley.

4. Under the above condition, insert a metallic bar (A) of approximately 6 mm (0.24 in) in diameter (hexagonal bar wrench shown as example in the figure) through the holding boss to lock auto tensioner pulley arm.
 - Leave auto tensioner pulley arm locked until belt is installed again.
5. Remove alternator, water pump and A/C compressor belt.

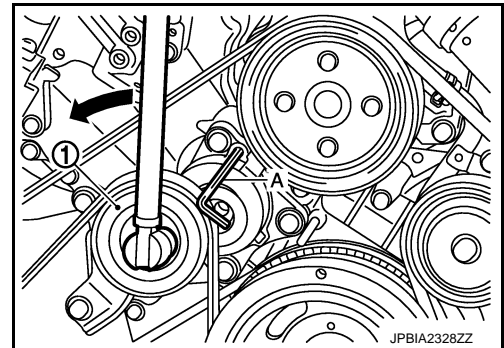

Power Steering Oil Pump Belt

1. Remove engine undercover with power tool.
2. Remove alternator, water pump and A/C compressor belt. Refer to "Alternator, Water Pump and A/C Compressor Belt".
3. With box wrench, and while securely holding the hexagonal part in pulley center of auto tensioner (1), move wrench handle in the direction of arrow (loosening direction of belt).

CAUTION:

- Never place hand in a location where pinching may occur if the holding tool accidentally comes off.
- Never loosen the hexagonal part in center of auto tensioner pulley (Never turn it clockwise). If turned clockwise, the complete auto tensioner must be replaced as a unit, including the pulley.

4. Under the above condition, insert a metallic bar (A) of approximately 6 mm (0.24 in) in diameter (hexagonal bar wrench shown as example in the figure) through the holding boss to lock auto tensioner pulley arm.
 - Leave auto tensioner pulley arm locked until belt is installed again.
5. Remove power steering oil pump belt.

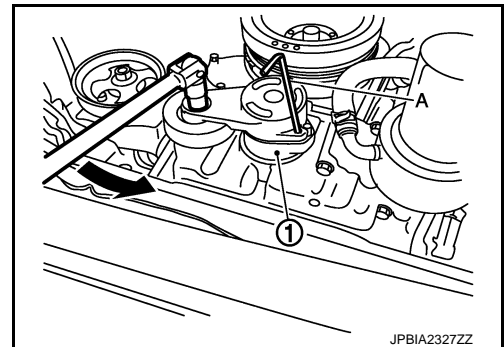

INSTALLATION

Note the following item, and install in the reverse order of removal.

CAUTION:

- Check drive belts are securely installed around all pulleys.
- Check drive belts are correctly engaged with the pulley groove.
- Check for engine oil and engine coolant are not adhered drive belts and pulley groove.

Inspection

INFOID:000000003733404

INSPECTION AFTER INSTALLATION

DRIVE BELTS

< PERIODIC MAINTENANCE >

[VK50VE]

- Turn crankshaft pulley clockwise several times to equalize tension between each pulley, and then confirm tension of drive belts at indicator (notch on fixed side) is within the possible use range. Refer to [EM-163](#), "[Exploded View](#)".

A

EM

C

D

E

F

G

H

I

J

K

L

M

N

O

P

AIR CLEANER FILTER

Removal and Installation

INFOID:000000003733405

REMOVAL

1. Unhook clips (A).

- 1 : Holder
- 2 : Air cleaner case

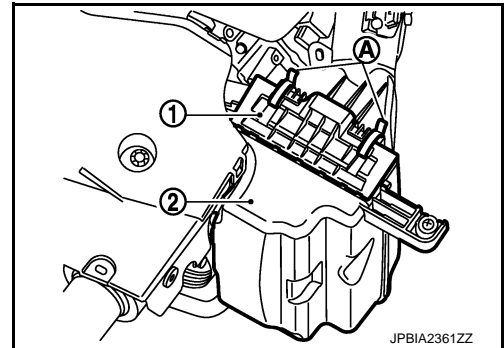

2. Remove air cleaner filter (2) from air cleaner case (3).

- 1 : Holder

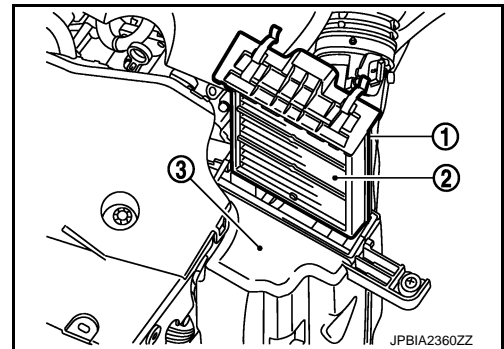

INSTALLATION

Note the following item, and install in the reverse order of removal.

- Install the air cleaner filter by aligning the seal with the notch of air cleaner case.

SPARK PLUG

< PERIODIC MAINTENANCE >

[VK50VE]

SPARK PLUG

Exploded View

INFOID:000000003733406

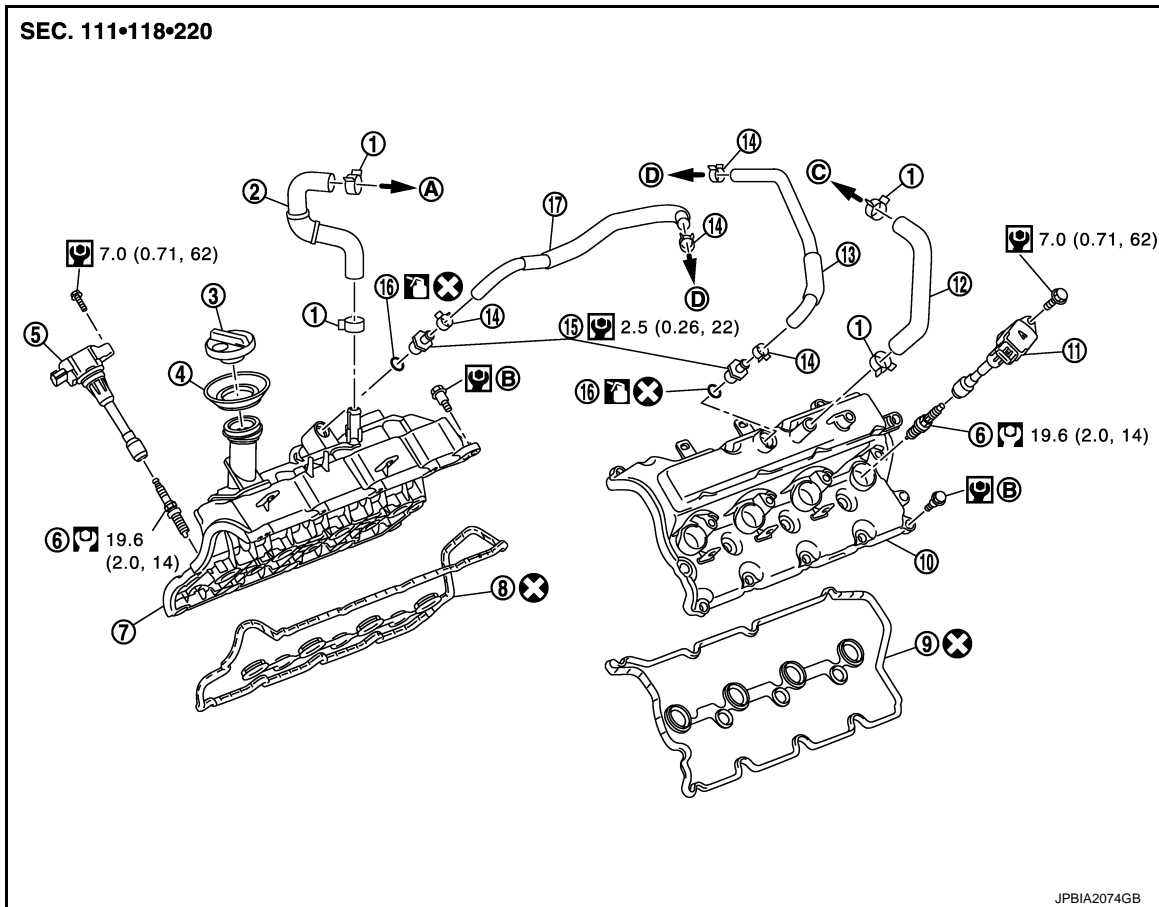

- | | | |
|---------------------------|------------------------------------|---------------------------------|
| 1. Clamp | 2. PCV hose | 3. Oil filler cap |
| 4. Oil catcher | 5. Ignition coil (No. 1 - 6) | 6. Spark plug |
| 7. Rocker cover (bank 2) | 8. Rocker cover gasket (bank 2) | 9. Rocker cover gasket (bank 1) |
| 10. Rocker cover (bank 1) | 11. Ignition coil (No. 7, 8) | 12. PCV hose |
| 13. PCV hose | 14. Clamp | 15. PCV valve |
| 16. O-ring | 17. PCV hose | |
| A. To air duct (bank 2) | B. Refer to EM-191 | C. To air duct (bank 1) |
| D. To intake manifold | | |

Refer to [GI-4, "Components"](#) for symbols in the figure.

Removal and Installation

INFOID:000000003733491

REMOVAL

1. Remove engine cover. Refer to [EM-174, "Exploded View"](#).
2. Remove ignition coil. Refer to [EM-191, "Exploded View"](#).

SPARK PLUG

[VK50VE]

< PERIODIC MAINTENANCE >

3. Remove spark plug with a spark plug wrench (commercial service tool).

a : 14 mm (0.55 in)

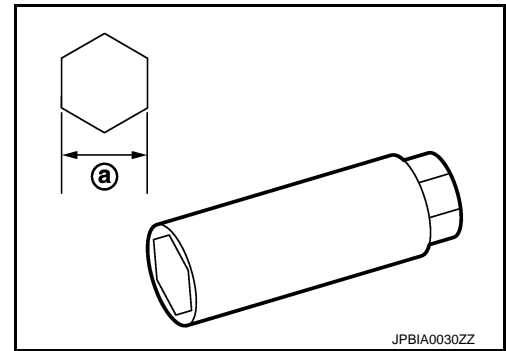

INSTALLATION

Installation is the reverse order of removal.

Inspection

INFOID:000000003733408

INSPECTION AFTER REMOVAL

Use the standard type spark plug for normal condition.

Spark plug (Standard type) : Refer to [EM-282, "Spark Plug"](#).

CAUTION:

- Never drop or impact spark plug.
- Never use a wire brush for cleaning.
- If plug tip is covered with carbon, use spark plug cleaner to clean.

Cleaner air pressure

: Less than 588 kPa (6 kg/cm², 85 psi)

Cleaning time

: Less than 20 seconds

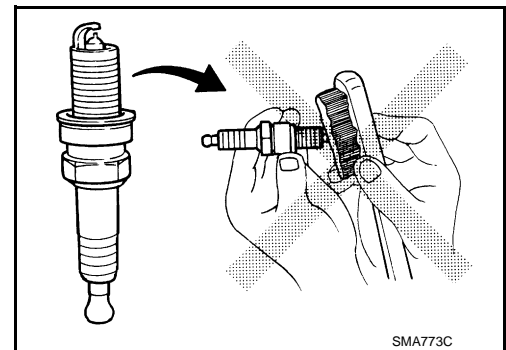

- Measure spark plug gap. When it exceeds the limit, replace spark plug even if it is within the specified replacement mileage. Refer to [EM-282, "Spark Plug"](#).
- Spark plug gap adjustment is not required between replacement intervals.

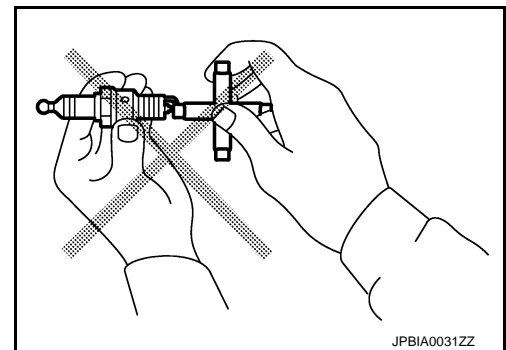

CAMSHAFT VALVE CLEARANCE

< PERIODIC MAINTENANCE >

[VK50VE]

CAMSHAFT VALVE CLEARANCE

Inspection

INFOID:000000003733409

INSPECTION

Check valve clearance if applicable to the following cases:

Intake side:

- At the removal and installation of VVEL ladder assembly or valve-related parts, or at the occurrence of malfunction (poor starting, idle malfunction, unusual noise) due to aged deterioration in valve clearance.

CAUTION:

Valve clearance check on the intake side is not required after replacing the VVEL ladder assembly & cylinder head assembly with a new one. (Install new VVEL ladder assembly & cylinder head assembly in factory-shipped condition because it is factory-adjusted and inspected.)

NOTE:

VVEL ladder assembly cannot be replaced as a single part, because it is machined together with cylinder head assembly.

Exhaust side:

- At the removal, installation, and replacement of camshaft (EXH) or valve-related parts, or at the occurrence of malfunction (poor starting, idle malfunction, unusual noise) due to aged deterioration in valve clearance.

1. Remove rocker covers (bank 1 and bank 2). Refer to [EM-191. "Removal and Installation"](#).
2. Measure the valve clearance as per the following:
 - Use the feeler gauge (commercial service tool) of curved-tip. This allows the feeler gauge to access the clearance between camshaft (drive shaft) nose and valve lifter with ease.

Valve clearance : Refer to [EM-283. "Camshaft"](#).

NOTE:

Be sure to note the following points when measuring valve clearance on the intake side.

- Before measuring, check that the position of drive shaft nose is within the angle shown in the figure.

A : Bank 2

B : Feeler gauge (commercial service tool)

c : 45 degrees (drive shaft nose angle)

D : View D

↖ : Insertion direction of feeler gauge on the bank 2

↙ : Insertion direction of feeler gauge on the bank 1

- Refer to the figure for the insertion direction of the feeler gauge since the direction depends on the bank.

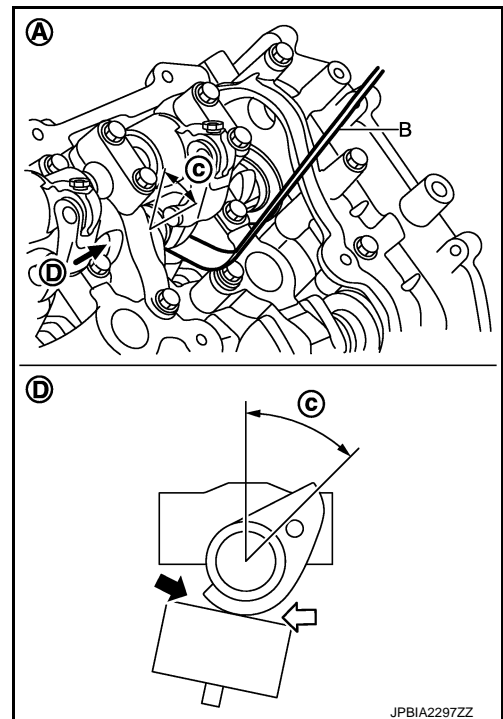

- a. Set No. 1 cylinder at TDC of its compression stroke.

CAMSHAFT VALVE CLEARANCE

[VK50VE]

< PERIODIC MAINTENANCE >

- Rotate crankshaft pulley clockwise to align timing mark (grooved line without color) (B) with timing indicator (A).

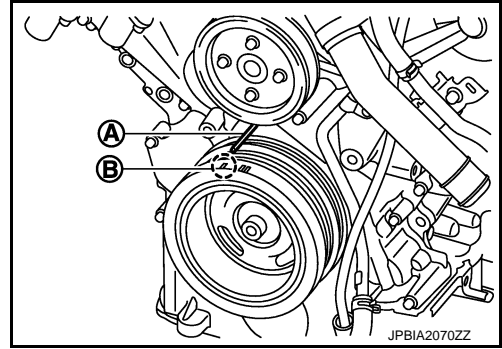

- Check that exhaust cam nose on No. 1 cylinder (engine front side of bank 1) is located as shown in the figure.

1 : Camshaft (EXH) (bank 1)

↶ : Engine front

- If not, turn crankshaft one revolution (360 degrees) and align as shown in the figure.

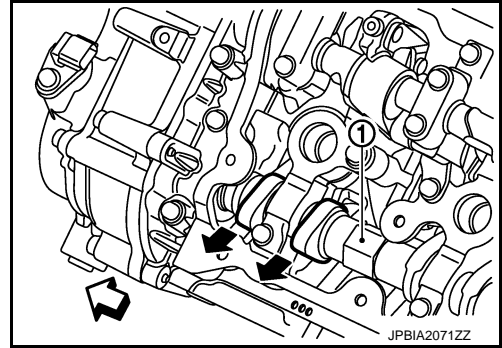

- By referring to the figure, measure the valve clearances at locations marked "x" as shown in the table below (locations indicated in the figure).

↶ : Engine front

- No. 1 cylinder at compression TDC

Measuring position [bank 2 (A)]		No. 2 CYL.	No. 4 CYL.	No. 6 CYL.	No. 8 CYL.
No. 1 cylinder at compression TDC	EXH				× (C)
	INT	× (D)	× (E)		
Measuring position [bank 1 (B)]		No. 1 CYL.	No. 3 CYL.	No. 5 CYL.	No. 7 CYL.
No. 1 cylinder at compression TDC	INT	× (F)		× (G)	
	EXH	× (H)			× (I)

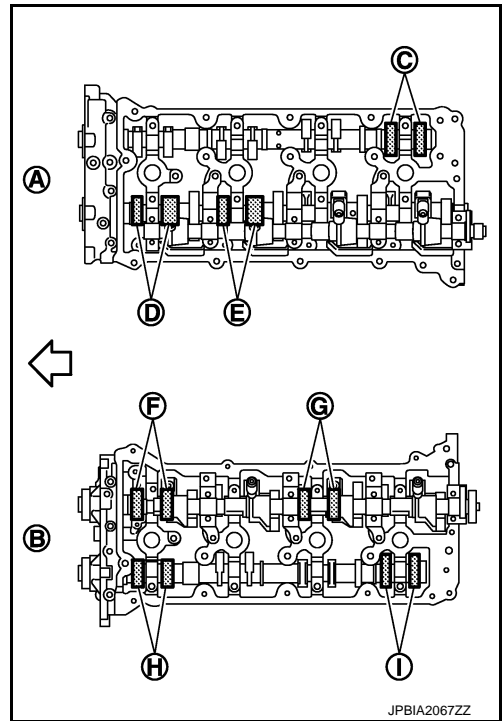

NOTE:

CAMSHAFT VALVE CLEARANCE

< PERIODIC MAINTENANCE >

[VK50VE]

To measure valve clearance of No. 1 cylinder INT valve (front side), insert feeler gauge (commercial service tool) from the front side (A) of the control shaft bracket or camshaft (EXH) side (B).

1 : Valve lifter

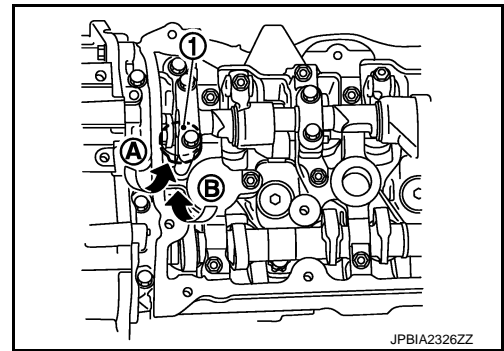

- b. Rotate crankshaft 270 degrees clockwise (when viewed from engine front) to align No. 3 cylinder at TDC its compression stroke.

NOTE:

Crankshaft pulley mounting bolt flange has an angle mark (B) every 90 degrees (c). They can be used as a guide to rotation angle.

A : Paint mark

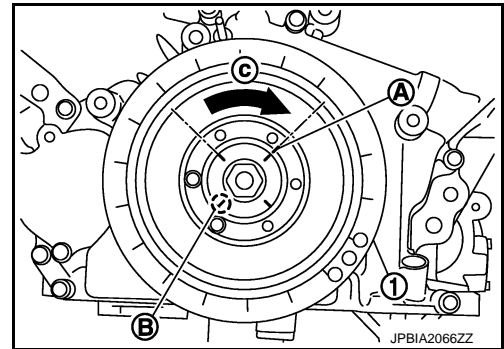

- By referring to the figure, measure the valve clearances at locations marked "x" as shown in the table below (locations indicated in the figure).

← : Engine front

- No. 3 cylinder at compression TDC

Measuring position [bank 2 (A)]		No. 2 CYL.	No. 4 CYL.	No. 6 CYL.	No. 8 CYL.
No. 3 cylinder at compression TDC	EXH		× (C)		
	INT				× (D)
Measuring position [bank 1 (B)]		No. 1 CYL.	No. 3 CYL.	No. 5 CYL.	No. 7 CYL.
No. 3 cylinder at compression TDC	INT		× (E)		× (F)
	EXH		× (G)	× (H)	

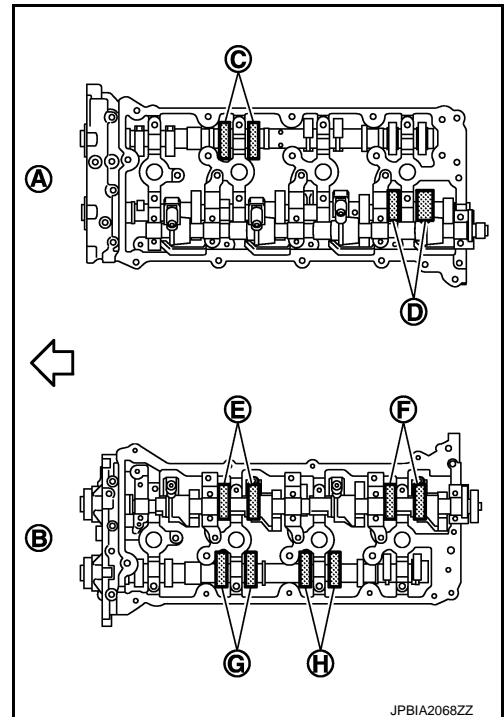

- c. Rotate crankshaft 90 degrees clockwise (when viewed from engine front) to align No. 6 cylinder at TDC of compression stroke.

NOTE:

CAMSHAFT VALVE CLEARANCE

[VK50VE]

< PERIODIC MAINTENANCE >

Crankshaft pulley mounting bolt flange has an angle mark (B) every 90 degrees (c). They can be used as a guide to rotation angle.

A : Paint mark

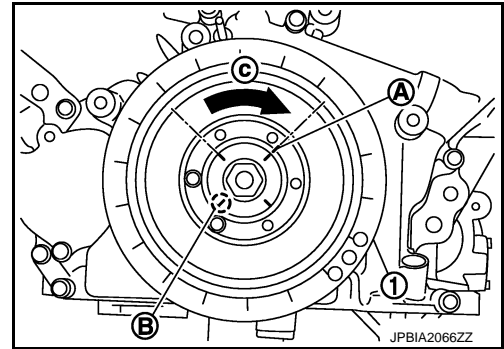

- By referring to the figure, measure the valve clearances at locations marked "x" as shown in the table below (locations indicated in the figure).

⇐ : Engine front

- No. 6 cylinder at compression TDC

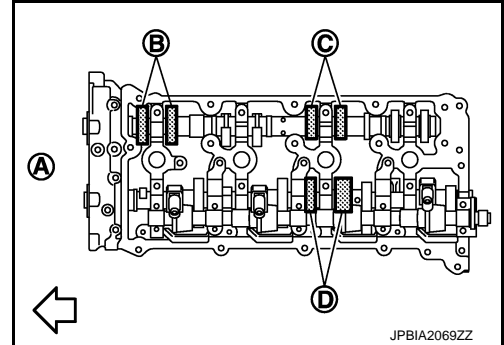

Measuring position [bank 2 (A)]		No. 2 CYL.	No. 4 CYL.	No. 6 CYL.	No. 8 CYL.
No. 6 cylinder at compression TDC	EXH	× (B)		× (C)	
	INT			× (D)	

3. Perform adjustment or replacement if the measured value is out of the standard.
 - If a valve clearance on the exhaust side is out of specification, adjust the valve clearance. Refer to [EM-236, "Inspection"](#).
 - If a valve clearance on the intake side is out of specification, replace VVEL ladder assembly & cylinder head assembly. Refer to [EM-227, "Exploded View"](#).

CAUTION:

Never adjust valve clearance on the intake side.

NOTE:

Since the valve lifter (INT) cannot be replaced by the piece, VVEL ladder assembly & cylinder head assembly replacement are required.

COMPRESSION PRESSURE

Inspection

INFOID:000000003733410

1. Warm up engine thoroughly. Then, stop it.
2. Release fuel pressure. Refer to [EC-1228, "Inspection"](#).
3. Disconnect fuel pump fuse (1) from IPDM E/R (2) to avoid fuel injection during measurement.

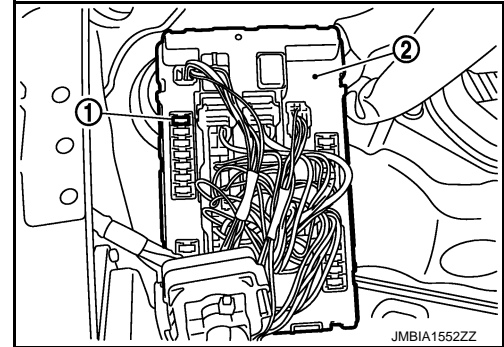

4. Remove engine cover. Refer to [EM-174, "Exploded View"](#).
5. Remove ignition coil and spark plug from each cylinder. Refer to [EM-191, "Exploded View"](#).
6. Connect engine tachometer (not required in use of CONSULT-III).
7. Measure compression pressure using compression gauge connected with flexible type adapter (commercial service tool).
8. With accelerator pedal fully depressed, turn ignition switch to "START" for cranking. When the gauge pointer stabilizes, read the compression pressure and the engine rpm. Perform these steps to check each cylinder.

Compression pressure : Refer to [EM-282, "General Specification"](#).

CAUTION:

- Measure a six-cylinder under the same conditions since a measurement depends on measurement conditions (engine water temperature, etc.).
 - Always use a fully charged battery to obtain the specified engine speed.
 - If the engine speed is out of the specified range, check battery liquid for proper gravity. Check the engine speed again with normal battery gravity. Refer to [PG-3, "How to Handle Battery"](#).
 - If compression pressure is below the minimum value, check valve clearances and parts associated with combustion chamber (valve, valve seat, piston, piston ring, cylinder bore, cylinder head, and cylinder head gasket). After checking, measure compression pressure again.
 - If a cylinder has low compression pressure, pour a small amount of engine oil into the spark plug hole of the cylinder to recheck it for compression.
 - If the added engine oil improves the compression, piston rings may be worn out or damaged. Check piston rings and replace if necessary. Refer to [EM-256, "Disassembly and Assembly"](#).
 - If the compression pressure remains at low level despite the addition of engine oil, valves may be malfunctioning. Check valves for damage. Replace valve or valve seat accordingly. Refer to [EM-256, "Disassembly and Assembly"](#).
 - If two adjacent cylinders have respectively low compression pressure and their compression remains low even after the addition of engine oil, cylinder head gaskets are leaking. In such a case, replace cylinder head gaskets. Refer to [EM-246, "Disassembly and Assembly"](#).
9. After inspection is completed, install removed parts.
 10. Start the engine, and check that the engine runs smoothly.
 11. Perform trouble diagnosis. If DTC appears, erase it. Refer to [EC-731, "Description"](#).

ENGINE ROOM COVER

< REMOVAL AND INSTALLATION >

[VK50VE]

REMOVAL AND INSTALLATION

ENGINE ROOM COVER

Exploded View

INFOID:000000003733411

Engine room cover

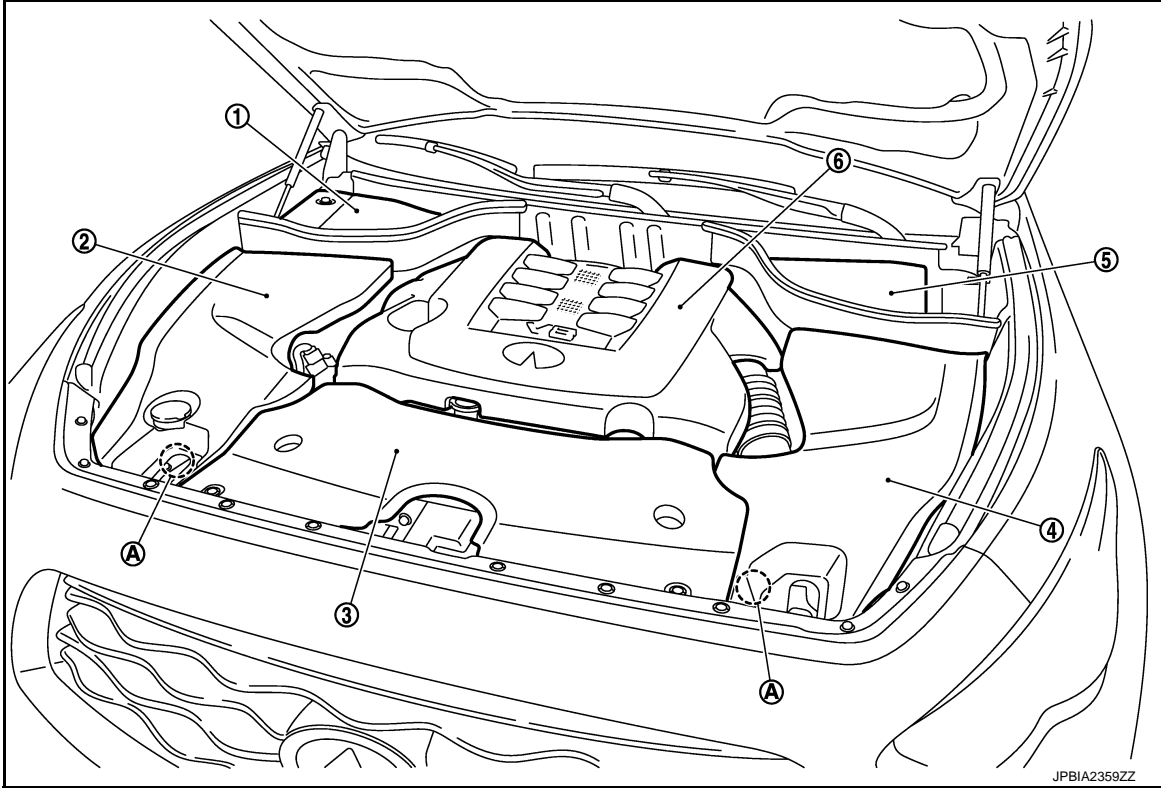

- 1. Battery cover
- 2. Engine room cover (RH)
- 3. Air duct (inlet)
- 4. Engine room cover (LH)
- 5. Brake master cylinder cover
- 6. Engine cover
- A. Clip

Refer to [GI-4, "Components"](#) for symbols in the figure.

Engine cover

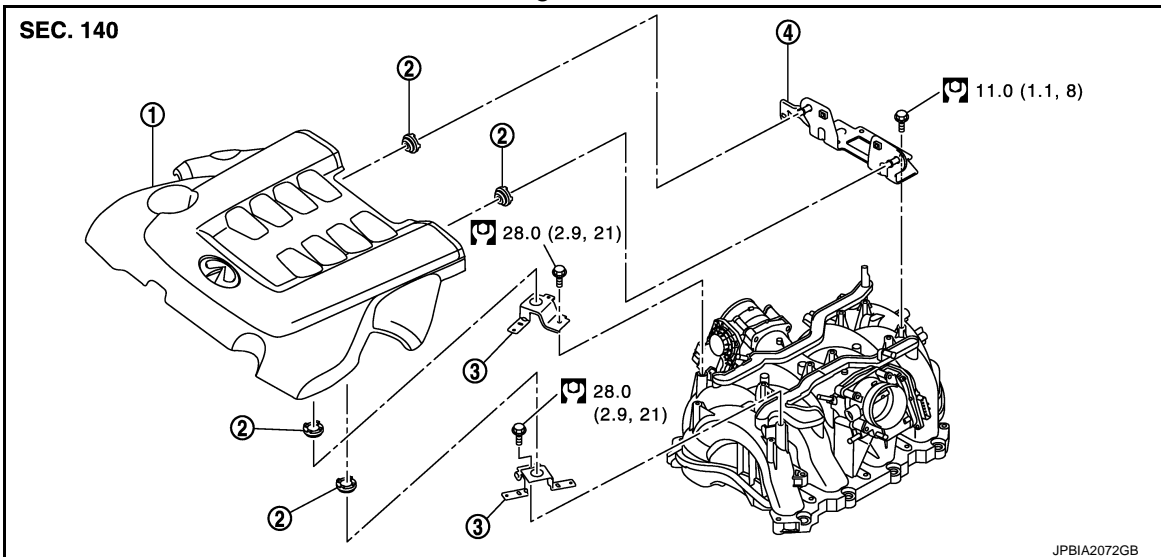

ENGINE ROOM COVER

< REMOVAL AND INSTALLATION >

[VK50VE]

- | | | | |
|-------------------|------------|------------|---|
| 1. Engine cover | 2. Grommet | 3. Bracket | A |
| 4. Bracket (rear) | | | |

Refer to [GI-4, "Components"](#) for symbols in the figure.

Removal and Installation

INFOID:000000003733412

EM

REMOVAL

CAUTION:

Never damage or scratch engine cover when installing or removing.

1. Remove clip, and remove engine room cover (RH and LH). C
2. Remove engine cover as per the following: D
 - Front side: Lift and remove fit.
 - Rear side: Pull out to forward and remove fit.
3. Remove battery cover and brake master cylinder cover, if necessary. E
4. Remove air duct (inlet). Refer to [EM-177, "Exploded View"](#). F

INSTALLATION

Installation is the reverse order of removal.

G

H

I

J

K

L

M

N

O

P

DRIVE BELT AUTO TENSIONER AND IDLER PULLEY

< REMOVAL AND INSTALLATION >

[VK50VE]

DRIVE BELT AUTO TENSIONER AND IDLER PULLEY

Exploded View

INFOID:000000003733413

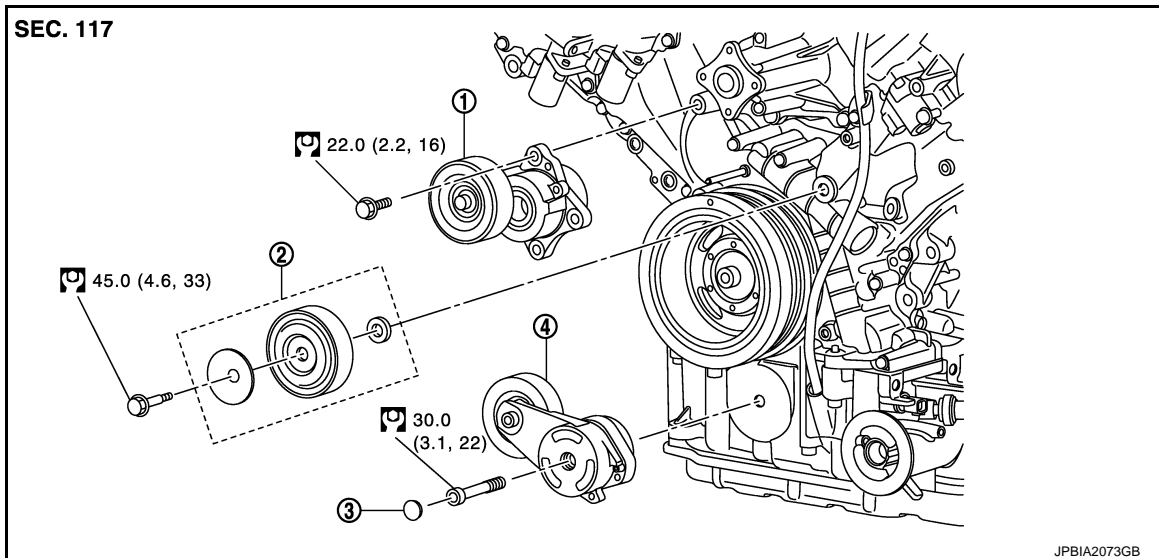

1. Auto-tensioner (for alternator, water pump and A/C compressor belt)
2. Idler pulley
3. Cover
4. Auto-tensioner (for power steering oil pump belt)

Refer to [GI-4, "Components"](#) for symbols in the figure.

Removal and Installation

INFOID:000000003733414

Removal

CAUTION:

The complete drive belt auto-tensioner must be replaced as a unit, including the pulley.

1. Remove drive belts. Refer to [EM-163, "Exploded View"](#).
 - Keep auto-tensioner pulley arm locked after drive belt is removed.
2. Remove drive belt auto-tensioners.
 - Keep auto-tensioner pulley arm locked to install or remove auto-tensioner.

CAUTION:

Never loosen the hexagonal part in center of drive belt auto tensioner pulley (Never turn it clockwise). If turned clockwise, the complete drive belt auto tensioner must be replaced as a unit, including the pulley.

3. Remove idler pulley.

Installation

Installation is the reverse order of removal.

CAUTION:

Never swap the pulley between new and old drive belt auto tensioner.

AIR CLEANER AND AIR DUCT

[VK50VE]

< REMOVAL AND INSTALLATION >

- **Never impact mass air flow sensor.**
- **Never disassemble mass air flow sensor.**
- **Never touch mass air flow sensor.**

INSTALLATION

Note the following item, and install in the reverse order of removal.

- Align marks. Attach each joint. Screw clamps firmly.

Clamp tightening torque  :4.5 N·m (0.46 kg-m, 40 in-lb)

Inspection

INFOID:000000003733417

INSPECTION AFTER REMOVAL

Inspect air duct assembly for crack or tear.

- If damage is found, replace air duct assembly

INTAKE MANIFOLD

< REMOVAL AND INSTALLATION >

[VK50VE]

INTAKE MANIFOLD

Exploded View

INFOID:000000003733418

A

EM

C

D

E

F

G

H

I

J

K

L

M

N

O

P

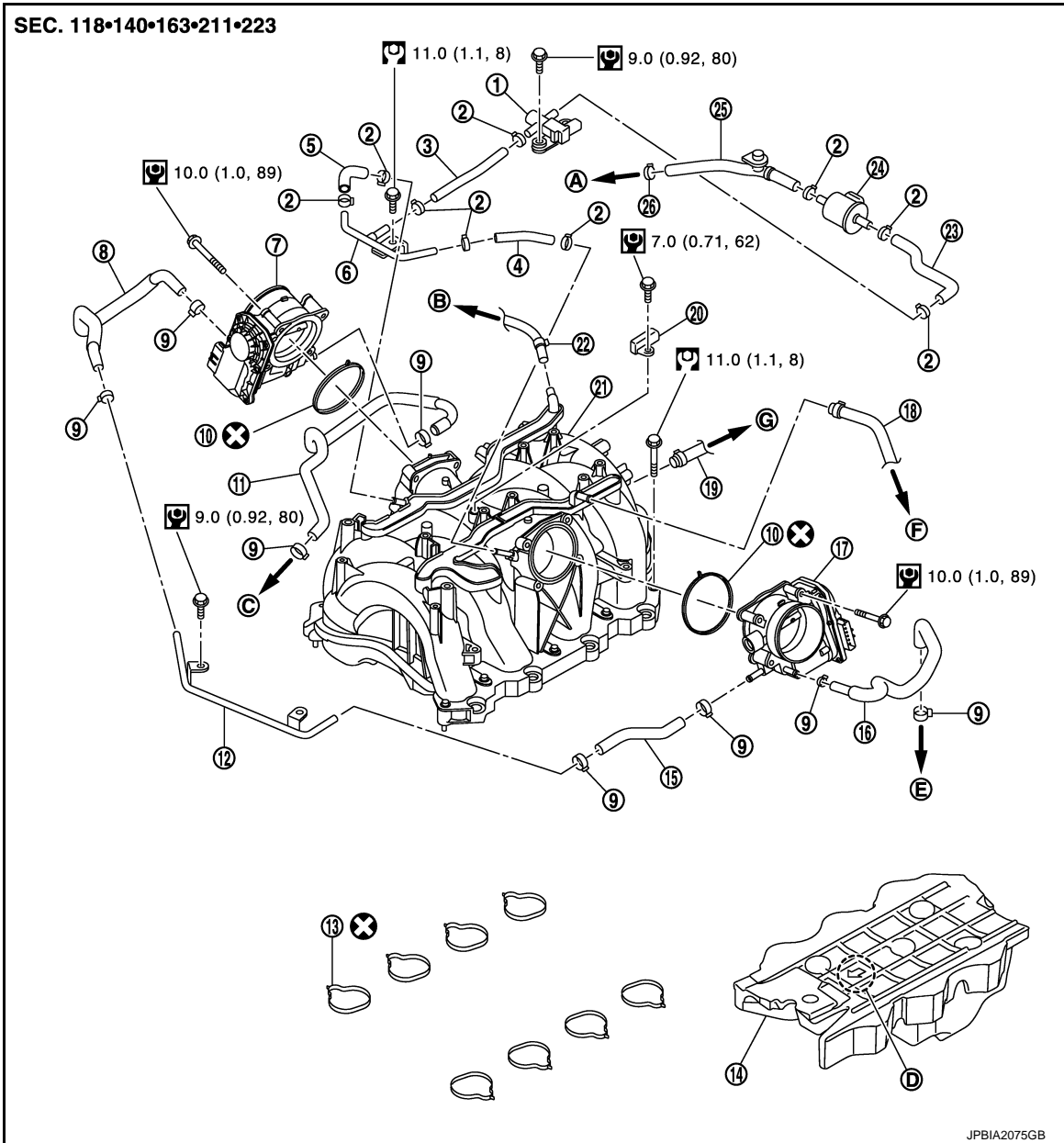

JPBIA2075GB

- | | | |
|--|---|---------------------|
| 1. EVAP canister purge control solenoid valve | 2. Clamp | 3. EVAP hose |
| 4. EVAP hose | 5. EVAP hose | 6. EVAP tube |
| 7. Electric throttle control actuator (bank 2) | 8. Water hose | 9. Clamp |
| 10. Gasket | 11. Water hose | 12. Water pipe |
| 13. Gasket | 14. Acoustic absorbent | 15. Water hose |
| 16. Water hose | 17. Electric throttle control actuator (bank 1) | 18. PCV hose |
| 19. Vacuum hose | 20. Manifold absolute pressure (MAP) sensor | 21. Intake manifold |
| 22. PCV hose | 23. EVAP hose | 24. Vacuum tank |
| 25. EVAP service port hose | 26. Clamp | |

INTAKE MANIFOLD

< REMOVAL AND INSTALLATION >

[VK50VE]

- | | | |
|--------------------------------------|-----------------------------|-----------------------------|
| A. To centralized under-floor piping | B. To rocker cover (bank 2) | C. To water inlet |
| D. Front mark | E. To cylinder head | F. To rocker cover (bank 1) |
| G. To brake booster | | |

Refer to [GI-4, "Components"](#) for symbols in the figure.

Removal and Installation

INFOID:000000003733419

REMOVAL

WARNING:

To avoid the danger of being scalded, never drain the engine coolant when the engine is hot.

1. Remove engine cover and engine room cover (RH and LH). Refer to [EM-174, "Exploded View"](#).
2. Release fuel pressure. Refer to [EC-1228, "Inspection"](#).
3. Remove air duct (inlet) and air duct. Refer to [EM-177, "Exploded View"](#).
4. Remove quick connector cap (1) and disconnect fuel feed hose (2) on engine side. Refer to [EM-182, "Exploded View"](#).

⇐ : Engine front

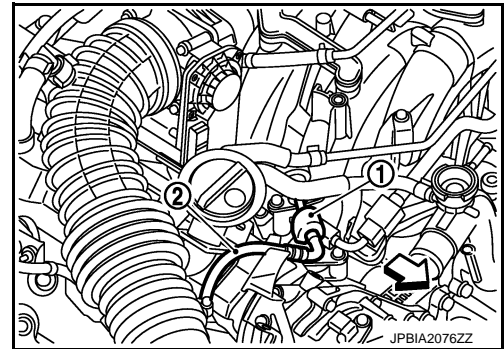

5. Remove engine cover bracket. Refer to [EM-174, "Exploded View"](#).
6. Remove fuel injector and fuel tube assembly. Refer to [EM-182, "Exploded View"](#).
7. Disconnect manifold absolute pressure (MAP) sensor and air fuel ratio sensor 1 (bank 1) harness connector.
8. Remove vacuum tank, EVAP service port hose and EVAP canister purge control solenoid valve.
9. Disconnect PCV hoses and vacuum hose from intake manifold.
 - Add matching marks as necessary for easier installation.
10. Drain engine coolant from radiator. Refer to [CO-33, "Draining"](#).

CAUTION:

- Perform this step when the engine is cold.
- Never spill engine coolant on drive belts.

NOTE:

When removing only intake manifold, move electric throttle control actuator without disconnecting the water hoses.

11. Remove electric throttle control actuator.
 - Loosen mounting bolts in reverse order as shown in the figure.

NOTE:

- The figure shows the electric throttle control actuator (bank 1) viewed from the air duct side.
- Viewed from the air duct side, the order of loosening mounting bolts of electric throttle control actuator (bank 1) is the same as that of the electric throttle control actuator (bank 2).

CAUTION:

- Handle carefully to avoid any impact to electric throttle control actuator.
- Never disassemble.

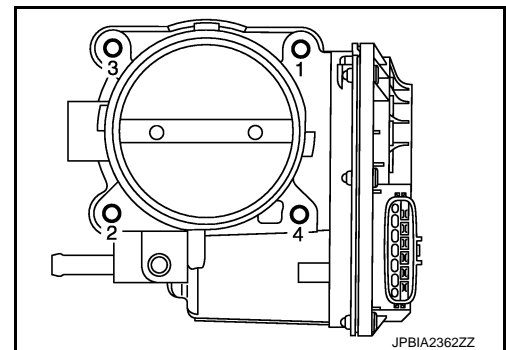

12. Remove intake manifold with power tool.

INTAKE MANIFOLD

[VK50VE]

< REMOVAL AND INSTALLATION >

- Loosen mounting bolts in reverse order as shown in the figure.

← : Engine front

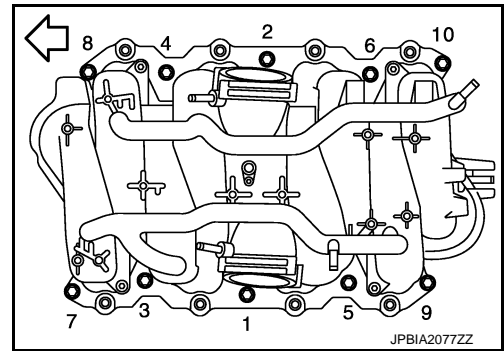

- Remove intake manifold gaskets.

CAUTION:

Cover engine openings to avoid entry of foreign materials.

- Remove manifold absolute pressure (MAP) sensor, if necessary.

CAUTION:

Handle carefully to avoid any impact to manifold absolute pressure (MAP) sensor.

- Remove acoustic absorbent.

INSTALLATION

Note the following item, and install in the reverse order of removal.

Intake Manifold

Tighten in numerical order as shown in the figure.

← : Engine front

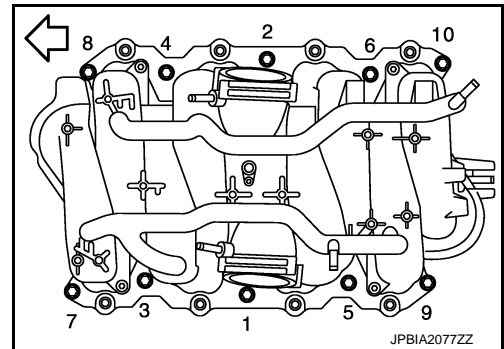

Electric Throttle Control Actuator

- Tighten in numerical order as shown in the figure.

NOTE:

- The figure shows the electric throttle control actuator (bank 1) viewed from the air duct side.
- Viewed from the air duct side, the order of tightening mounting bolts of electric throttle control actuator (bank 1) is the same as that of the electric throttle control actuator (bank 2).
- Perform the "Throttle Valve Closed Position Learning" when harness connector of electric throttle control actuator is disconnected. Refer to [EC-582, "THROTTLE VALVE CLOSED POSITION LEARNING : Description"](#).
- Perform the "Idle Air Volume Learning" and "Throttle Valve Closed Position Learning" when electric throttle control actuator is replaced. Refer to [EC-583, "IDLE AIR VOLUME LEARNING : Description"](#) and [EC-582, "THROTTLE VALVE CLOSED POSITION LEARNING : Description"](#).

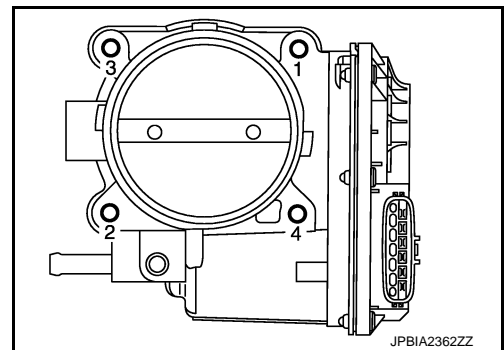

Water Hose

Insert hose by 27 to 32 mm (1.06 to 1.26 in) from connector end.

Vacuum Hose

Refer to [EC-1229, "Inspection"](#).

FUEL INJECTOR AND FUEL TUBE

< REMOVAL AND INSTALLATION >

[VK50VE]

FUEL INJECTOR AND FUEL TUBE

Exploded View

INFOID:000000003733426

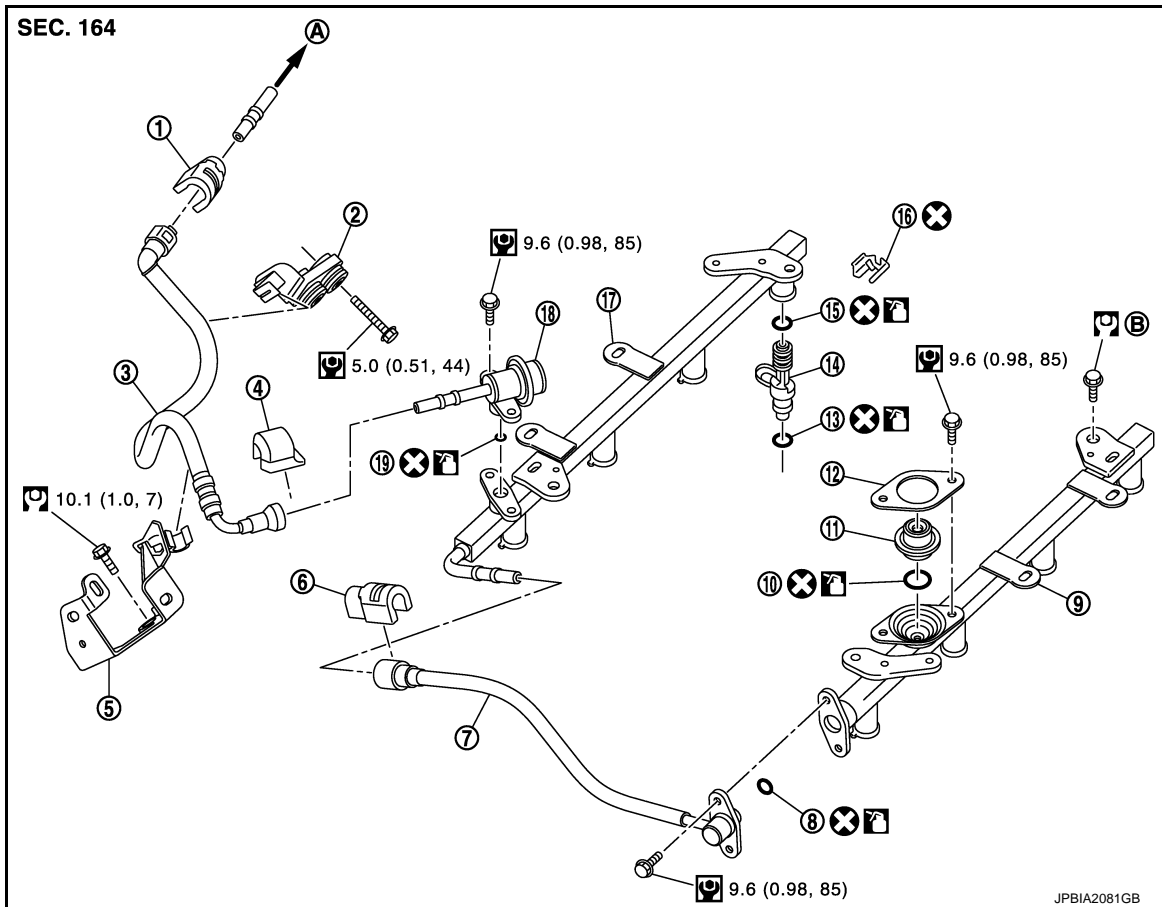

- | | | |
|------------------------|------------------------|------------------------|
| 1. Quick connector cap | 2. Fuel hose bracket | 3. Fuel feed hose |
| 4. Quick connector cap | 5. Fuel hose bracket | 6. Quick connector cap |
| 7. Fuel hose (center) | 8. O-ring | 9. Fuel tube (bank 1) |
| 10. O-ring | 11. Fuel damper | 12. Fuel damper cap |
| 13. O-ring (green) | 14. Fuel injector | 15. O-ring (black) |
| 16. Clip | 17. Fuel tube (bank 2) | 18. Fuel feed damper |
| 19. O-ring | | |

A. To centralized under-floor piping B. Refer to [EM-182](#)

Refer to [GI-4, "Components"](#) for symbols in the figure.

CAUTION:

Never remove or disassemble parts unless instructed as shown in the figure.

Removal and Installation

INFOID:000000003733427

REMOVAL

WARNING:

- Put a "CAUTION: FLAMMABLE" sign in the workshop.
- Be sure to work in a well ventilated area and furnish workshop with a CO₂ fire extinguisher.
- Never smoke while servicing fuel system. Keep open flames and sparks away from the work area.
- To avoid the danger of being scalded, never drain engine coolant when engine is hot.

1. Remove engine cover and engine room cover (RH and LH). Refer to [EM-174, "Exploded View"](#).
2. Release fuel pressure. Refer to [EC-1228, "Inspection"](#).

FUEL INJECTOR AND FUEL TUBE

[VK50VE]

< REMOVAL AND INSTALLATION >

3. Remove the fuel feed hose (2) on the fuel feed damper side with quick connector release (commercial service tool: J-45488) as per the followings steps.

1. : Quick connector cap

↶ : Engine front

CAUTION:

Use the quick connector release for removing the fuel feed hose on the centralized under-floor piping side as well as the fuel feed damper side although the shape of the quick connector is different.

- a. Remove quick connector cap from quick connector connection.
b. With the sleeve side (B) of quick connector release (A) facing to quick connector (D), install quick connector release onto fuel feed hose.

1 : Fuel feed damper

C : Insert and retain

- c. Insert quick connector release into quick connector until sleeve contacts and goes no further. Hold quick connector release on that position.

CAUTION:

Inserting quick connector release hard will not disconnect quick connector. Hold quick connector release where it contacts and goes no further.

- d. Pull out quick connector straight from fuel feed damper.

CAUTION:

- Pull quick connector holding position (E) as shown in the figure.
- Never pull with lateral force applied. O-ring inside quick connector may be damaged.
- Prepare container and cloth beforehand as fuel will leak out.
- Avoid fire and sparks.
- Keep parts away from heat source. Especially, be careful when welding is performed around them.
- Never expose parts to battery electrolyte or other acids.
- Never bend or twist connection between quick connector and fuel feed hose during installation/removal.
- To keep the connecting portion clean and to avoid damage and foreign materials, cover them completely with plastic bags (A) or something similar.

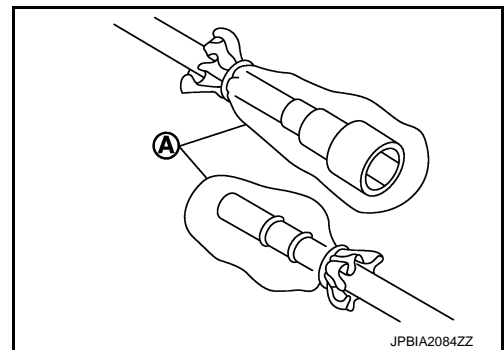
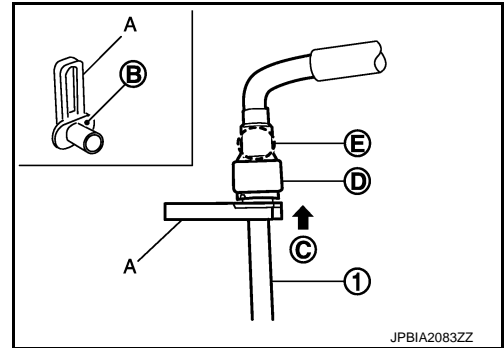
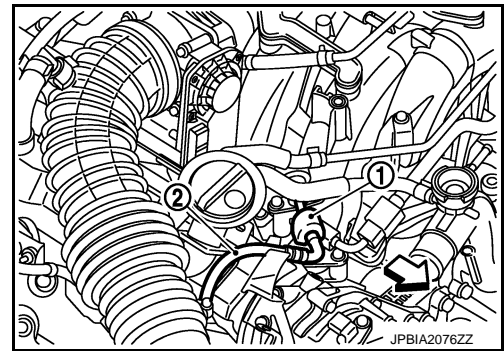

4. Remove air duct. Refer to [EM-177, "Exploded View"](#).
5. Remove electric throttle control actuator. Refer to [EM-179, "Exploded View"](#).
6. Remove fuel hose (center).
• The procedure for removing the quick connector is the same as for removing the fuel feed damper.

CAUTION:

Disconnect quick connector by using quick connector release (commercial service tool: J-45488), not by picking out retainer tabs.

7. Remove fuel tube and fuel injector assembly.

FUEL INJECTOR AND FUEL TUBE

[VK50VE]

< REMOVAL AND INSTALLATION >

- Loosen mounting bolts (b) first. Then loosen mounting bolts (a) shown in the figure.

- 1 : Fuel tube (bank 2)
 2 : Fuel tube (bank 1)
 ⇐ : Engine front

CAUTION:

Never tilt it, or remaining fuel in pipes may flow out from pipes.

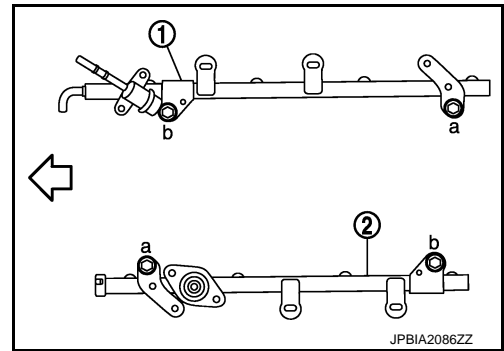

8. Remove fuel injector (1) from fuel tube (3) as per the following:

- A : Installed condition
 B : Clip mounting groove
 C : Protrusion

- a. Open and remove clip (2).
 b. Remove fuel injector from fuel tube by pulling straight.

CAUTION:

- Be careful with remaining fuel that may go out from fuel tube.
- Be careful not to damage injector nozzles during removal.
- Never bump or drop fuel injector.
- Never disassemble fuel injector.

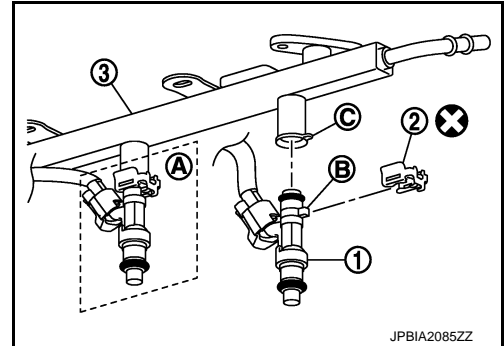

9. Disconnect sub harness connector from fuel injectors.
 10. Remove fuel damper and fuel feed damper, if necessary.

INSTALLATION

1. Install fuel damper (4) as per the following:

- 1 : Fuel damper cap

- a. Install new O-ring (3) to fuel tube (bank 1) (2) as shown. When handling new O-ring, pay attention to the following caution items:

CAUTION:

- Handle O-ring with bare hands. Never wear gloves.
- Lubricate O-ring with new engine oil.
- Never clean O-ring with solvent.
- Check that O-ring and its mating part are free of foreign material.
- When installing O-ring, be careful not to scratch it with tool or fingernails. Also be careful not to twist or stretch O-ring. If O-ring was stretched while it was being attached, never insert it quickly into fuel tube.
- Insert new O-ring straight into fuel tube. Never decenter or twist it.

- b. Install spacer (A) to fuel damper. Insert fuel damper straight into fuel tube (bank 1).

CAUTION:

- Insert straight, check that the axis is lined up.
- Insert fuel damper at 130 N (13.3 kg, 29.2 lb) or less to prevent damage to the parts
- Insert fuel damper until the rim (C) reaches the cap flange (B).

- c. Tighten mounting bolts evenly in turn.
 • After tightening mounting bolts, check that there is no gap between flange and fuel tube (bank 1).

2. Install fuel feed damper.

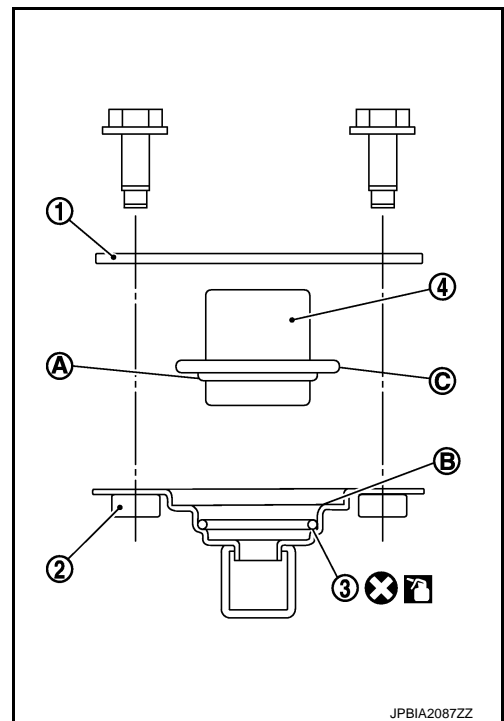

FUEL INJECTOR AND FUEL TUBE

[VK50VE]

< REMOVAL AND INSTALLATION >

- Handling procedure of O-ring is the same as that of fuel damper.
- Insert fuel feed damper straight into fuel tube (bank 2).

CAUTION:

Insert fuel feed damper at 147 N (15 kg, 33.1 lb) or less to prevent damage to the parts

- Tighten mounting bolts evenly in turn.
- After tightening mounting bolts, check that there is no gap between flange and fuel tube (bank 2).

3. Install new O-rings to fuel injector paying attention to the following caution.

CAUTION:

- **Upper and lower O-ring are different. Be careful not to confuse them.**

Fuel tube side : Black

Nozzle side : Green

- Handle O-ring with bare hands. Never wear gloves.
- Lubricate O-ring with new engine oil.
- Never clean O-ring with solvent.
- Check that O-ring and its mating part are free of foreign material.
- When installing O-ring, be careful not to scratch it with tool or fingernails. Also be careful not to twist or stretch O-ring. If O-ring was stretched while it was being attached, never insert it quickly into fuel tube.
- Insert O-ring straight into fuel injector. Never decenter or twist it.

4. Install fuel injector (3) to fuel tube (1) as per the following:

2 : O-ring (black)

4 : O-ring (green)

- a. Insert clip (5) into clip mounting groove (B) on fuel injector.
 - Insert clip so that protrusion (C) of fuel injector matches cutout (E) of clip.

CAUTION:

- Never reuse clip. Replace it with a new one.
- Be careful to keep clip from interfering with O-ring. If interference occurs, replace O-ring.

- b. Insert fuel injector into fuel tube with clip attached.
 - Insert it while matching it to the axial center.
 - Insert fuel injector so that protrusion (G) of fuel tube matches cutout (F) of clip.
 - Check that fuel tube flange (A) is securely fixed in flange fixing groove (D) on clip.

CAUTION:

Insert fuel injector at 147 N (15 kg, 33.1 lb) or less to prevent damage to the parts

- c. Check that installation is complete by checking that fuel injector does not rotate or come off.
 - Check that protrusions of fuel injectors and fuel tube are aligned with cutouts of clips after installation.

5. Install fuel tube and fuel injector assembly.

- Tighten mounting bolts (a) first. Then tighten mounting bolts (b) shown in the figure.

1 : Fuel tube (bank 2)

2 : Fuel tube (bank 1)

⇐ : Engine front

1st step : 10.1 N-m (1.0 kg-m, 7 ft-lb)

2nd step : 23.6 N-m (2.4 kg-m, 17 ft-lb)

CAUTION:

- Be careful not to let tip of injector nozzle come in contact with other parts.

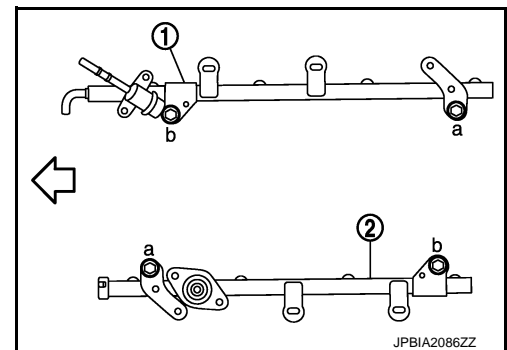
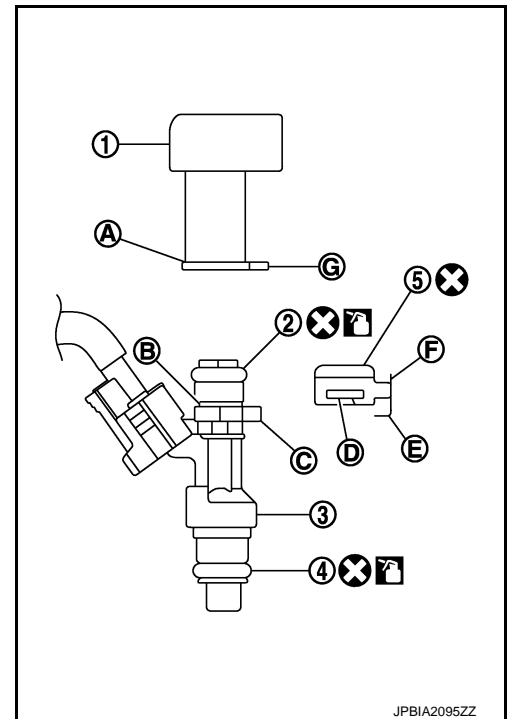

A
EM
C
D
E
F
G
H
I
J
K
L
M
N
O
P

FUEL INJECTOR AND FUEL TUBE

[VK50VE]

< REMOVAL AND INSTALLATION >

- Insert fuel injector at 147 N (15 kg, 33.1 lb) or less to prevent damage to the parts

6. Install quick connectors as per the following:
 - Unless otherwise indicated, the installation to the engine side and centralized under-floor piping side is exactly alike.
- a. Check no foreign substances are deposited in and around fuel piping and quick connector, and no damage on them.
- b. Thinly apply new engine oil around fuel piping from tip end to spool end.
- c. Align center to insert quick connector straightly into fuel piping.

Fuel hose (center) and centralized under-floor piping side:

- Visually confirm that the two retainer tabs (A) are connected to the quick connector (B).

CAUTION:

- Carefully align center to avoid inclined insertion to prevent damage to O-ring inside quick connector.
- Insert until you hear a “click” sound and actually feel the engagement.
- To avoid misidentification of engagement with a similar sound, be sure to perform the next step.

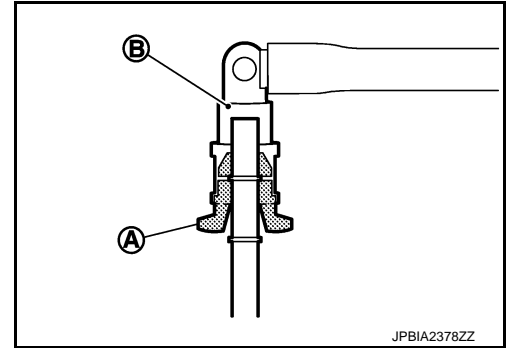

Fuel feed damper side:

- Insert quick connector to fuel feed damper piping until top spool (2) is completely inside quick connector and 2nd level spool (3) exposes just below quick connector.

B : Fitted condition

⇐ : Upright insertion

CAUTION:

- Hold (A) position as shown in the figure when inserting fuel feed hose (1) into quick connector.
- Carefully align center to avoid inclined insertion to prevent damage to O-ring inside quick connector.
- Insert until you hear a “click” sound and actually feel the engagement.
- To avoid misidentification of engagement with a similar sound, be sure to perform the next step.

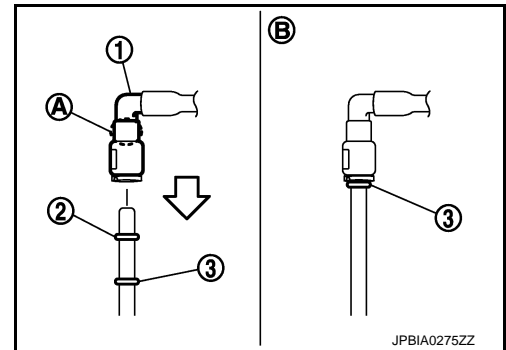

- d. Pull quick connector by hand holding position (A). Check it is completely engaged (connected) so that it does not come out from fuel piping (1).

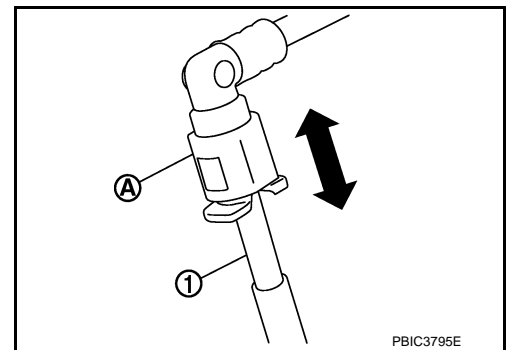

FUEL INJECTOR AND FUEL TUBE

[VK50VE]

< REMOVAL AND INSTALLATION >

e. Install quick connector cap (3) to quick connector connection.

1 : Fuel tube (bank 1)

2 : Fuel hose (center)

- Install quick connector cap with arrow (A) on surface facing the direction of quick connector.

CAUTION:

If cap cannot be installed smoothly, quick connector may have not be installed correctly. Check connection again.

NOTE:

Figure shows an example fuel feed damper side.

7. Install in the reverse order of removal.

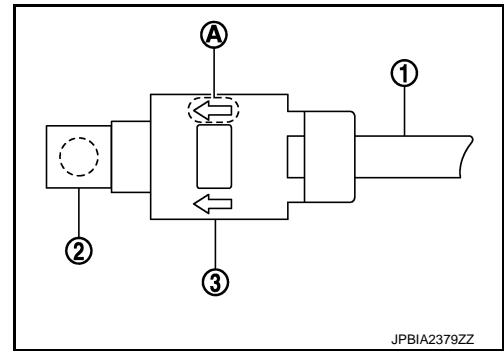

Inspection

INFOID:000000003733428

INSPECTION AFTER INSTALLATION

Check for Fuel Leakage

1. Turn ignition switch "ON" (with the engine stopped). With fuel pressure applied to fuel piping, check that there is no fuel leakage at connection points.

NOTE:

Use mirrors for checking at points out of clear sight.

2. Start the engine. With engine speed increased, check again that there is no fuel leakage at connection points.

CAUTION:

Never touch the engine immediately after it is stopped because the engine is extremely hot.

OIL PAN (LOWER) AND OIL STRAINER

< REMOVAL AND INSTALLATION >

[VK50VE]

OIL PAN (LOWER) AND OIL STRAINER

Exploded View

INFOID:000000003733429

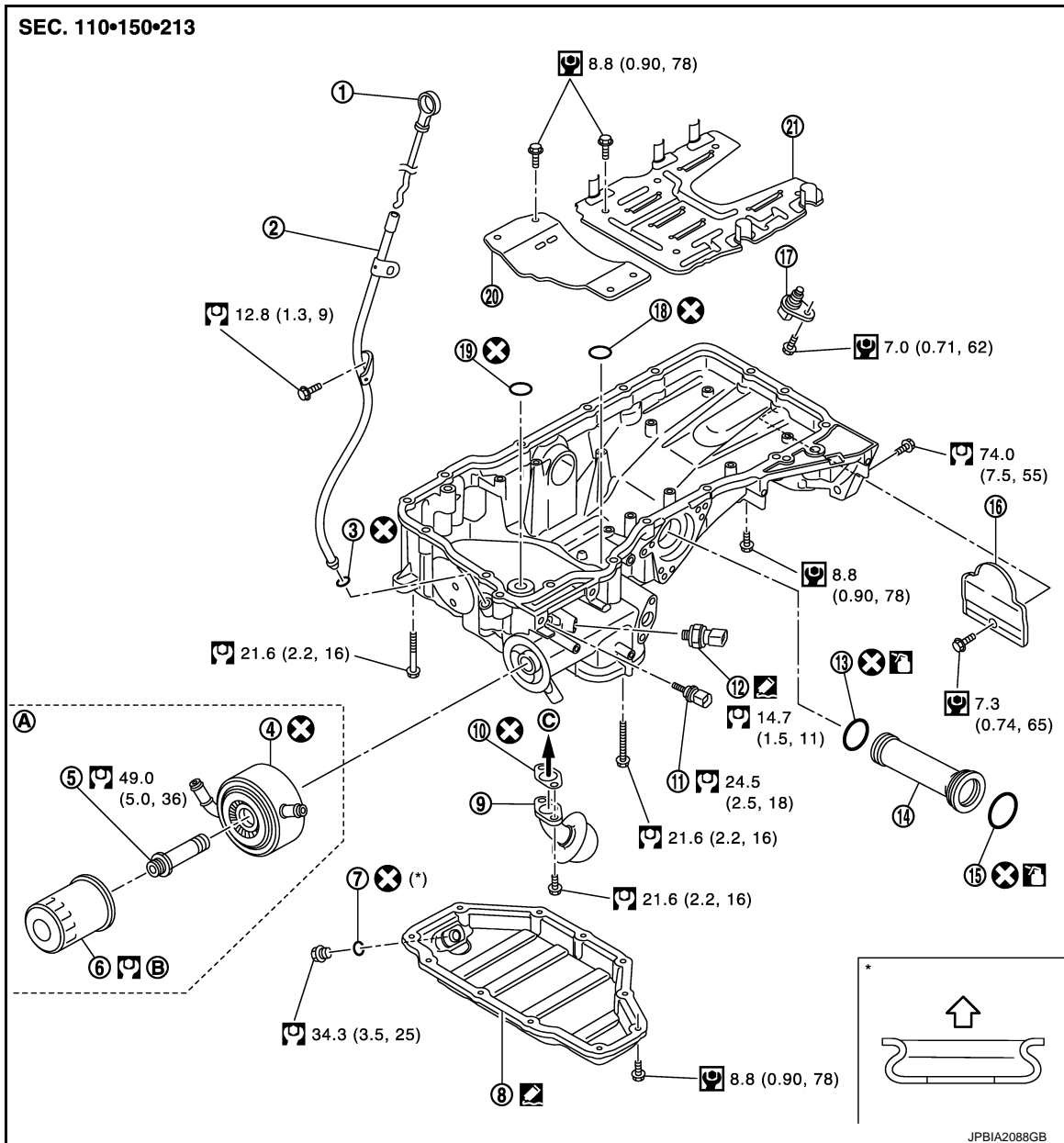

JPBIA2088GB

- | | | |
|-----------------------------------|--------------------------------------|-------------------------|
| 1. Oil level gauge | 2. Oil level gauge guide | 3. O-ring |
| 4. Oil cooler | 5. Connector bolt | 6. Oil filter |
| 7. Drain plug washer | 8. Oil pan (lower) | 9. Oil strainer |
| 10. Gasket | 11. Oil temperature sensor | 12. Oil pressure switch |
| 13. O-ring | 14. Axle pipe | 15. O-ring |
| 16. Rear plate cover | 17. Crankshaft position sensor (POS) | 18. O-ring |
| 19. O-ring | 20. Baffle plate | 21. Baffle plate |
| A. Refer to LU-29 | B. Refer to LU-28 | C. Oil pump side |

← : Oil pan side

Refer to [GI-4, "Components"](#) for symbols in the figure.

OIL PAN (LOWER) AND OIL STRAINER

< REMOVAL AND INSTALLATION >

[VK50VE]

INFOID:000000003733430

Removal and Installation

REMOVAL

WARNING:

To avoid the danger of being scalded, never drain engine oil when engine is hot.

1. Drain engine oil. Refer to [LU-26, "Draining"](#).
2. Remove oil pan (lower) as per the following:
 - a. Loosen mounting bolts in reverse order as shown in the figure to remove.

← : Engine front

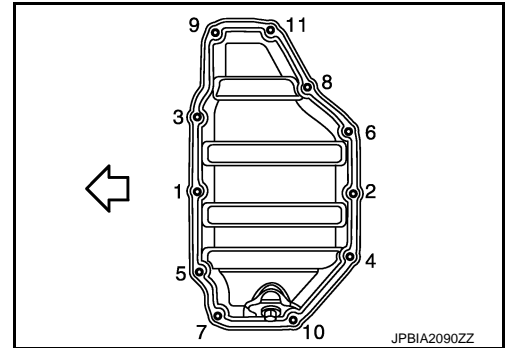

- b. Insert the seal cutter [SST: KV10111100 (J-37228)] (A) between oil pan (upper) and oil pan (lower).

CAUTION:

- Be careful not to damage the mating surfaces.
- Never insert a screwdriver. This damages the mating surfaces.

- c. Slide the seal cutter by tapping on the side of tool with a hammer. Remove oil pan (lower).

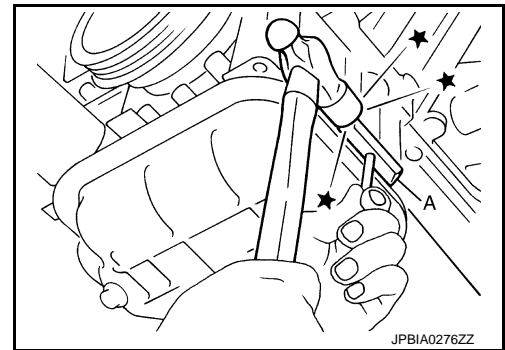

3. Remove oil strainer.

INSTALLATION

1. Install oil strainer.
2. Install oil pan (lower) as per the following:
 - a. Use scraper (A) to remove old liquid gasket from mating surfaces.

- Remove old liquid gasket from the bolt holes and thread.

CAUTION:

Never scratch or damage the mating surfaces when cleaning off old liquid gasket.

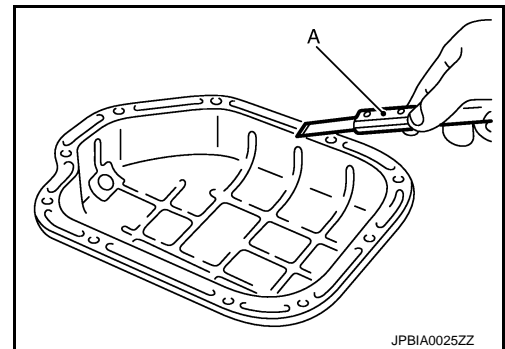

A
EM
C
D
E
F
G
H
I
J
K
L
M
N
O
P

OIL PAN (LOWER) AND OIL STRAINER

[VK50VE]

< REMOVAL AND INSTALLATION >

- b. Apply a continuous bead of liquid gasket with the tube presser (commercial service tool) to the oil pan (lower) as shown in the figure.

- a : 7.5 - 9.5 mm (0.295 - 0.374 in)
b : ϕ 4.0 - 5.0 mm (0.157 - 0.197 in)
↔ : Engine front

Use Genuine RTV Silicone Sealant or an equivalent. Refer to [GI-15, "Recommended Chemical Products and Sealants"](#).

CAUTION:

Attaching must be done within 5 minutes after coating.

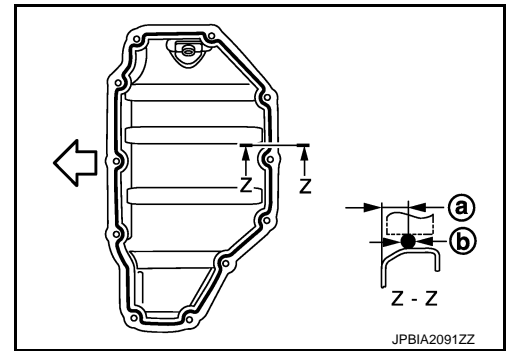

- c. Install oil pan (lower).
• Tighten mounting bolts in numerical order as shown in the figure.

↔ : Engine front

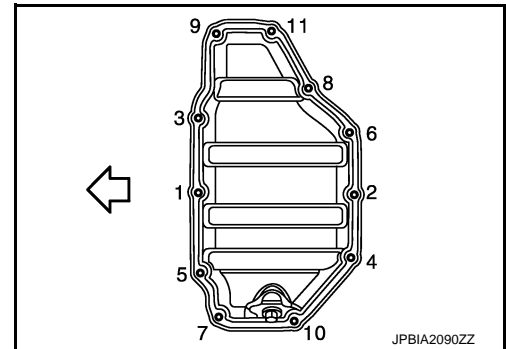

3. Install oil pan drain plug.
• Refer to the figure of the components of on the prior page for installation direction of drain plug washer.
Refer to [EM-188, "Exploded View"](#).
4. Install in the reverse order of removal after this step.
NOTE:
Wait at least 30 minutes after oil pan is installed before pouring engine oil.

Inspection

INFOID:000000003733431

INSPECTION AFTER REMOVAL

Clean oil strainer if any object is attached.

INSPECTION AFTER INSTALLATION

1. Check the engine oil level and adjust engine oil. Refer to [LU-25, "Inspection"](#).
2. Start engine, and check there is no leakage of engine oil.
3. Stop engine and wait for 15 minutes.
4. Check the engine oil level again. Refer to [LU-25, "Inspection"](#).

IGNITION COIL, SPARK PLUG AND ROCKER COVER

< REMOVAL AND INSTALLATION >

[VK50VE]

IGNITION COIL, SPARK PLUG AND ROCKER COVER

Exploded View

INFOID:000000003733432

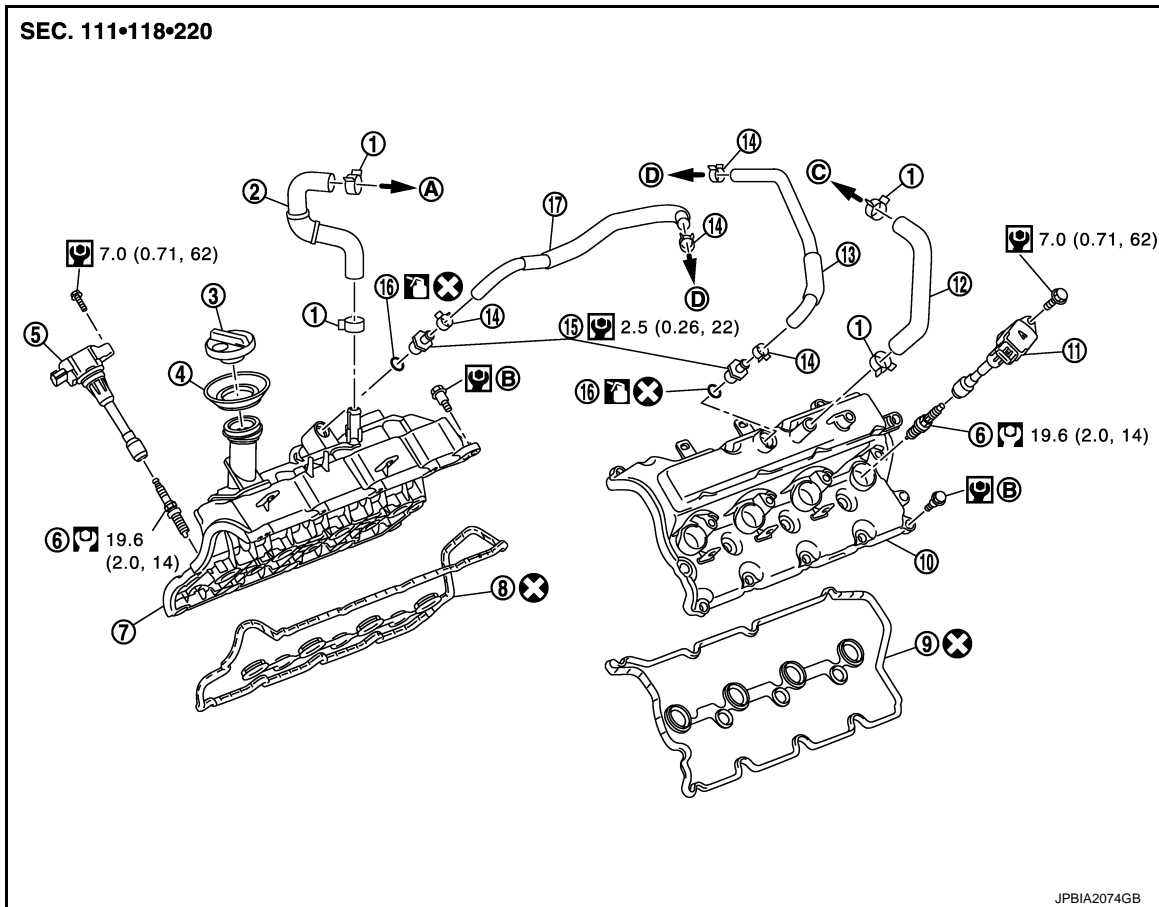

- | | | |
|---------------------------|------------------------------------|---------------------------------|
| 1. Clamp | 2. PCV hose | 3. Oil filler cap |
| 4. Oil catcher | 5. Ignition coil (No. 1 - 6) | 6. Spark plug |
| 7. Rocker cover (bank 2) | 8. Rocker cover gasket (bank 2) | 9. Rocker cover gasket (bank 1) |
| 10. Rocker cover (bank 1) | 11. Ignition coil (No. 7, 8) | 12. PCV hose |
| 13. PCV hose | 14. Clamp | 15. PCV valve |
| 16. O-ring | 17. PCV hose | |
| A. To air duct (bank 2) | B. Refer to EM-191 | C. To air duct (bank 1) |
| D. To intake manifold | | |

Refer to [GI-4, "Components"](#) for symbols in the figure.

Removal and Installation

INFOID:000000003733433

REMOVAL

- Remove the following parts:
 - Engine cover and engine room cover (RH and LH): Refer to [EM-174, "Exploded View"](#).
 - Air cleaner case and air duct: Refer to [EM-177, "Exploded View"](#).
 - Fuel feed hose: Refer to [EM-182, "Exploded View"](#).
- Disconnect PCV hose from rocker cover.
- Remove ignition coil.

CAUTION:
Never impact it.

NOTE:
Installation position of Ignition coil depends on cylinder position.

IGNITION COIL, SPARK PLUG AND ROCKER COVER

< REMOVAL AND INSTALLATION >

[VK50VE]

- Remove spark plugs. Refer to [EM-167, "Removal and Installation"](#).

CAUTION:

Never impact it.

- Remove rocker cover.
 - Loosen bolts in reverse order shown in the figure.

A : Bank 2

B : Bank 1

⇐ : Engine front

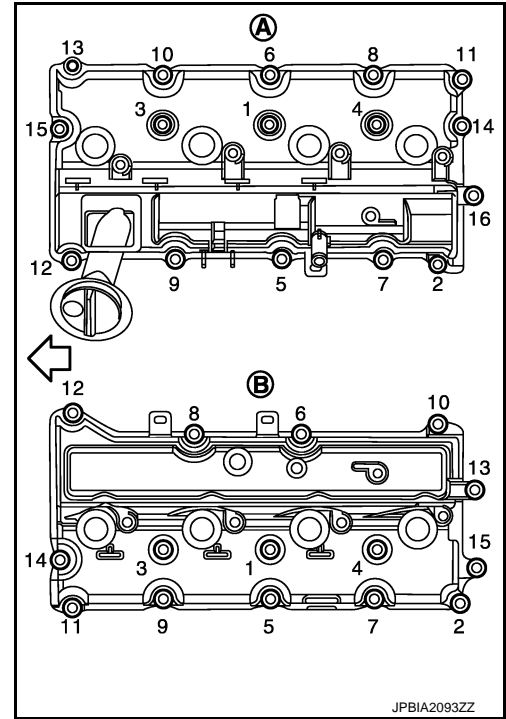

- Remove rocker cover gasket from rocker cover.
- Use scraper to remove all traces of liquid gasket from cylinder head & VVEL ladder assembly.

CAUTION:
Never scratch or damage the mating surface when cleaning off old liquid gasket.
- Remove PCV valve from rocker cover, if necessary.
- Remove oil filler cap and oil catcher from rocker cover, if necessary.

INSTALLATION

- Apply liquid gasket with the tube presser (commercial service tool) to VVEL ladder assembly (1) and actuator bracket (rear) (2).

3 : VVEL actuator sub assembly

A : Liquid gasket application point

F : End surface of VVEL ladder assembly

b : 4 mm (0.16 in)

c : 2.5 - 3.5 mm (0.098 - 0.138 in)

d : 5 mm (0.20 in)

e : 10 mm (0.39 in)

⇐ : Engine front

Use Genuine RTV Silicone Sealant or an equivalent. Refer to [GI-15, "Recommended Chemical Products and Sealants"](#).

NOTE:

The figure shows an example of bank 1 side.

- Apply liquid gasket on the front and rear side of engine first. [5 mm (0.20 in) + 5 mm (0.20 in) side as shown in the figure]

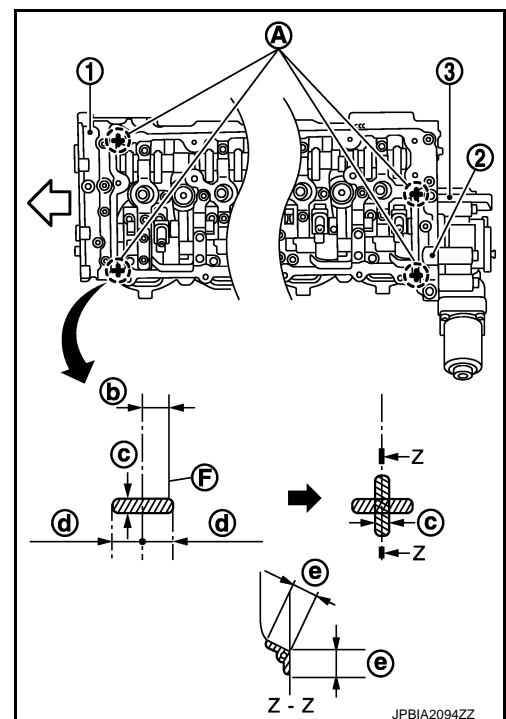



IGNITION COIL, SPARK PLUG AND ROCKER COVER

< REMOVAL AND INSTALLATION >

[VK50VE]

2. Install rocker cover gasket to rocker cover.
3. Install rocker cover.
 - Check that rocker cover gasket does not drop from the installation groove of rocker cover.
4. Tighten bolts in two steps separately in numerical order as shown in the figure.

- A : Bank 2
 B : Bank 1
 ← : Engine front

-  **1st step: 2.0 N·m (0.2 kg·m, 18 in·lb)**
-  **2nd step: 8.3 N·m (0.85 kg·m, 73 in·lb)**

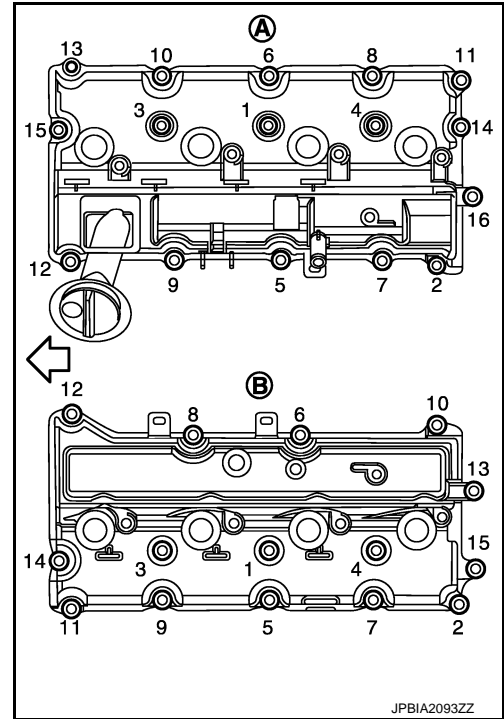

- Because of the limited working space, use adapter (A) and torque wrench (B) assembly [SST: KV10119300 (—)] to tighten bolts (on the No.7 and No. 8 cylinders) to the specified torque.

- ← : ENgine front

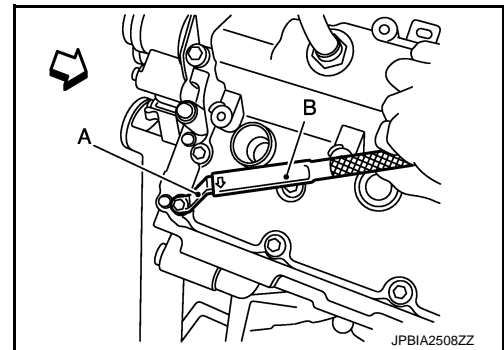

5. Install spark plug. Refer to [EM-167. "Removal and Installation"](#).
6. Install ignition coil.
 - Install Ignition coil marked with an identification mark (A) on cylinder No. 7 and 8.

- ← : Engine front

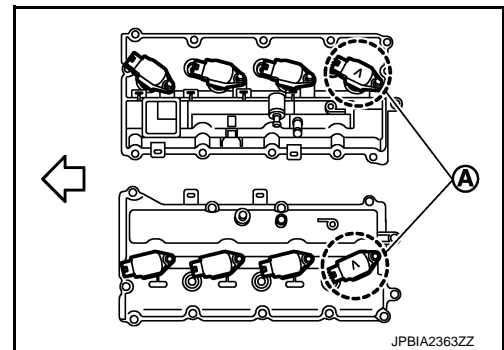

7. Install in the reverse order of removal.

A
EM
C
D
E
F
G
H
I
J
K
L
M
N
O
P

< REMOVAL AND INSTALLATION >

OIL SEAL

FRONT OIL SEAL

FRONT OIL SEAL : Removal and Installation

INFOID:000000003733437

REMOVAL

1. Remove the following parts:
 - Engine undercover with power tool.
 - Drive belts: Refer to [EM-163, "Exploded View"](#).
 - Cooling fan assembly: Refer to [CO-39, "Exploded View"](#).
 - Front cross bar: Refer to [FSU-34, "Exploded View"](#).
2. Remove crankshaft pulley as per the following:
 - a. Remove rear plate cover. Refer to [EM-188, "Exploded View"](#).
 - b. Set the ring gear stopper [SST: KV10119200 (J-49277)] (A) as shown in the figure.

⇐ : Engine front

- c. Loosen crankshaft pulley bolt, and then pull crankshaft pulley with both hands to remove it.

CAUTION:

Never remove crankshaft pulley bolt. Keep loosened crankshaft pulley bolt in place to protect removed crankshaft pulley from dropping.

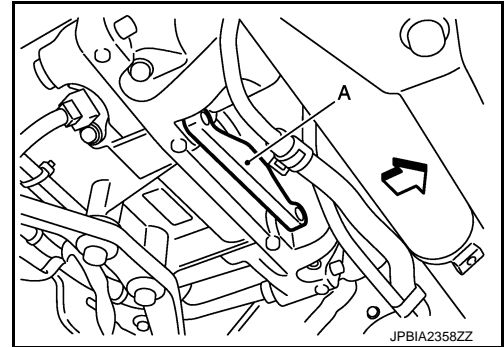

3. Remove front oil seal using a suitable tool.

CAUTION:

Be careful not to damage front cover and crankshaft.

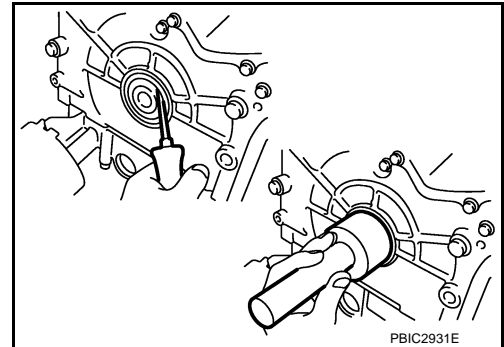

INSTALLATION

1. Install front oil seal on front cover.

⇐ : Engine inside

➡ : Engine outside

- Apply new engine oil to both oil seal lip (A) and dust seal lip (B).
- Install it so that each seal lip is oriented as shown in the figure.

CAUTION:

Be careful not to scratch or make burrs on circumference of oil seal.

- Using a suitable drift [outer diameter: 56 mm (2.20 in)], press-fit oil seal until it becomes flush with front cover end face.
- Check the garter spring is in position and seal lips are not inverted.

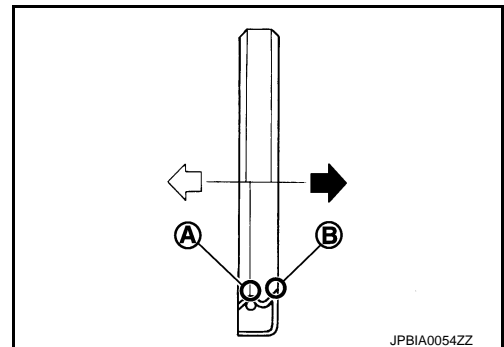

2. Install in the reverse order of removal.

REAR OIL SEAL

OIL SEAL

< REMOVAL AND INSTALLATION >

[VK50VE]

INFOID:000000003733438

REAR OIL SEAL : Removal and Installation

REMOVAL

1. Remove transmission assembly. Refer to [TM-384, "Exploded View"](#).
2. Remove drive plate . Refer to [EM-255, "Exploded View"](#).
3. Remove rear oil seal with a suitable tool.

CAUTION:

Be careful not to damage crankshaft and cylinder block.

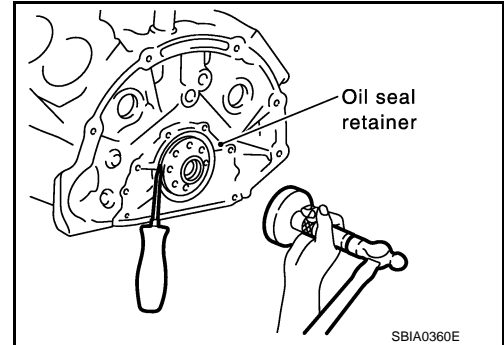

INSTALLATION

1. Install rear oil seal.
 - Install rear oil seal so that each seal lip is oriented as shown in the figure.

- A : Oil seal lip
- B : Dust seal lip
- ⇐ : Engine inside
- ⇨ : Engine outside

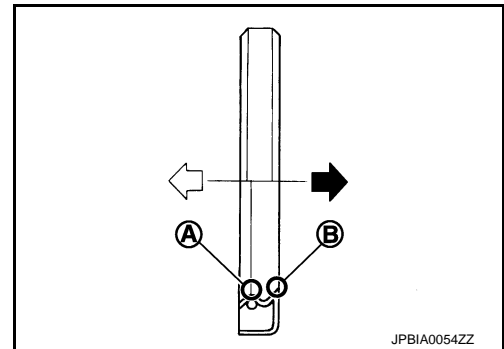

- Press in rear oil seal (1) to the position as shown in the figure.

- B : Rear oil seal retainer rear end face
- a : 0 - 0.5 mm (0 - 0.020 in)

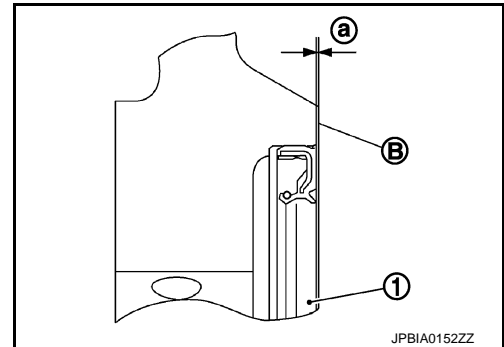

- Using a suitable drift [outer diameter 101 mm (3.98 in)], press-fit until the height of rear oil seal is level with the mounting surface.
- Check the garter spring is in position and seal lips are not inverted.

CAUTION:

- **Be careful not to damage crankshaft and cylinder block.**
- **Press-fit straight and avoid causing burrs or tilting oil seal.**

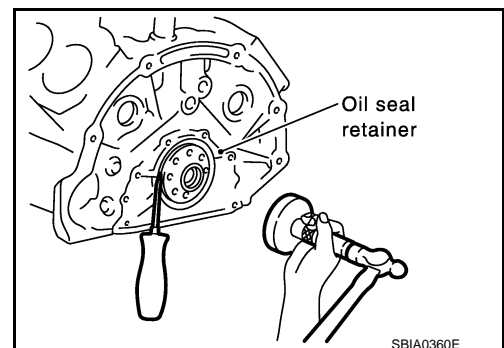

2. Install in the reverse order of removal after this step.

UNIT REMOVAL AND INSTALLATION

ENGINE ASSEMBLY

Exploded View

INFOID:000000003733439

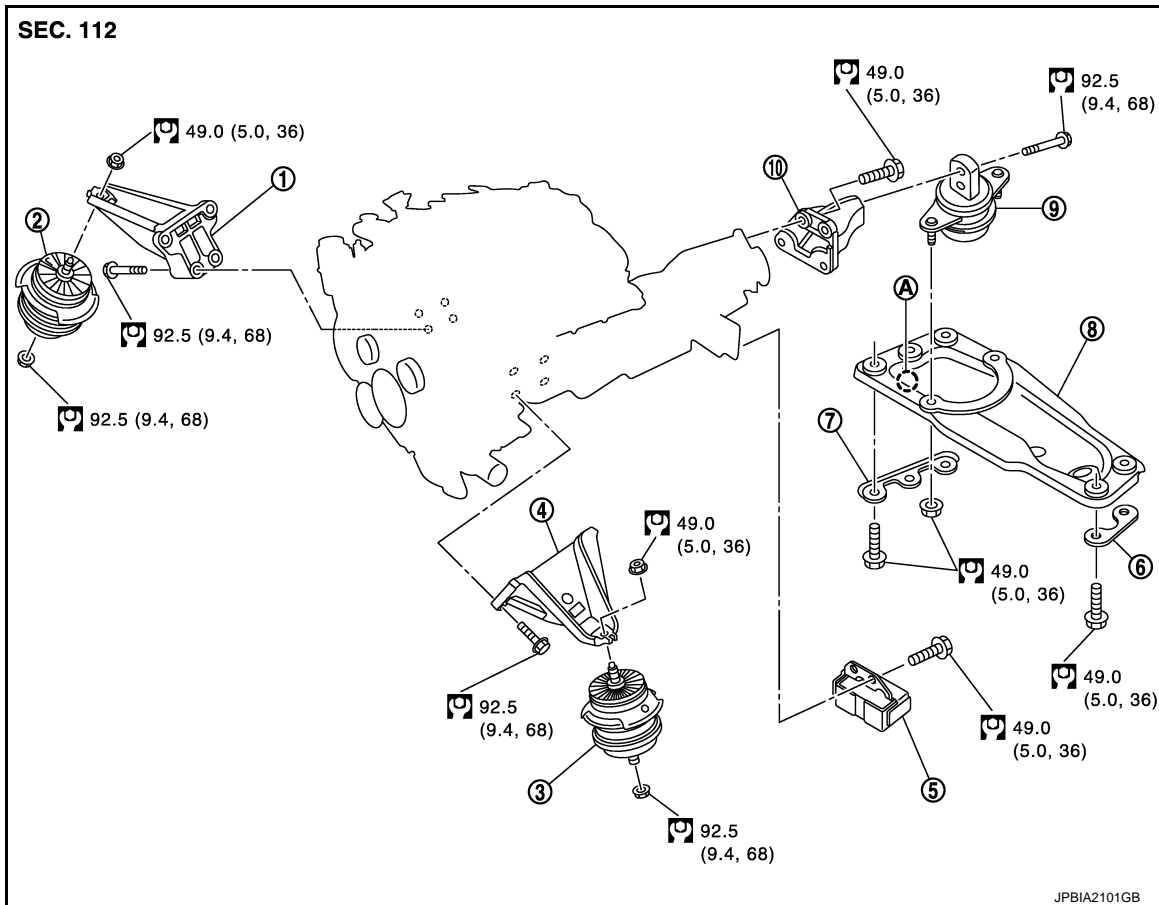

- | | | |
|------------------------------------|-----------------------------------|-------------------------------------|
| 1. Engine mounting bracket (RH) | 2. Engine mounting insulator (RH) | 3. Engine mounting insulator (LH) |
| 4. Engine mounting bracket (LH) | 5. Dynamic damper | 6. Heat insulator (LH) |
| 7. Heat insulator (RH) | 8. Rear engine mounting member | 9. Engine mounting insulator (rear) |
| 10. Engine mounting bracket (rear) | | |
| A. Front mark | | |

Refer to [GI-4. "Components"](#) for symbols in the figure.

Removal and Installation

INFOID:000000003733440

WARNING:

- Situate the vehicle on a flat and solid surface.
- Place chocks at the front and back of rear wheels.
- For engines not equipped with engine slingers, attach proper slingers and bolts described in PARTS CATALOG.

CAUTION:

- Always be careful to work safely, and avoid forceful or uninstructed operations.
- Never start working until exhaust system and engine coolant are cool enough.
- If items or work required are not covered by the engine section, refer to the applicable sections.
- Always use the support point specified for lifting.
- Use either 2-pole lift type or separate type lift as much as possible. If board-on type is used for unavoidable reasons, support at rear axle jacking point with transmission jack or similar tool before starting work, in preparation for the backward shift of the center of gravity.

ENGINE ASSEMBLY

< UNIT REMOVAL AND INSTALLATION >

[VK50VE]

- For supporting points for lifting and jacking point at rear axle, refer to [GI-26, "Garage Jack and Safety Stand and 2-Pole Lift"](#).

NOTE:

When removing/installing only the engine mounting, the hold engine assembly as instructed below:

1. Remove food assembly. Refer to [DLK-225, "HOOD ASSEMBLY : Exploded View"](#).
2. Install engine slinger on both front right and front left sides of the engine.
3. Hoist the slinger to obtain room for engine assembly.

CAUTION:

Use an engine lifter to prevent the engine slinger from falling and damaging the rocker cover.

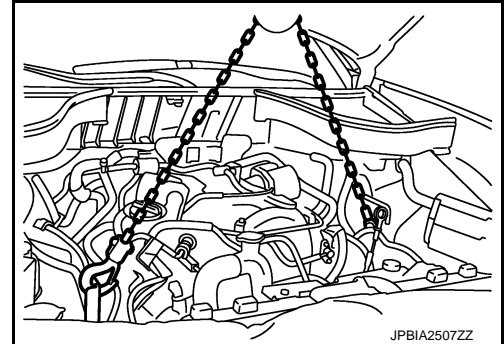

REMOVAL

Outline

At first, remove the engine, transmission, transfer and front final drive assembly with front suspension member facing downward. Then separate the engine from transmission.

Preparation

1. Remove engine cover, engine room cover (RH and LH), battery cover and brake master cylinder cover. Refer to [EM-174, "Exploded View"](#).
 2. Release fuel pressure. Refer to [EC-1228, "Inspection"](#).
 3. Remove the following parts:
 - Engine undercover (power tool)
 - Front road wheel and tires (power tool)
 - Cowl top cover: Refer to [EXT-22, "Exploded View"](#).
 - Air duct, air cleaner case assembly and PCV hose: Refer to [EM-177, "Exploded View"](#).
 - Drive belts: Refer to [EM-164, "Removal and Installation"](#).
 - Front cross bar: Refer to [FSU-34, "Exploded View"](#).
 4. Disconnect both battery cables. Refer to [PG-120, "Exploded View"](#).
 5. Drain engine coolant from radiator. Refer to [CO-33, "Draining"](#).
- CAUTION:**
Perform this step when engine is cold.
6. Discharge refrigerant from A/C circuit. Refer to [HA-81, "Collection and Charge"](#).
 7. Remove radiator hoses (upper and lower). Refer to [CO-39, "Exploded View"](#).

Engine Room LH

1. Disconnect heater hose at engine side, and fit a plug onto hose end to prevent engine coolant leakage.
2. Disconnect A/C piping from A/C compressor, and temporarily fasten it on vehicle with a rope. Refer to [HA-108, "Exploded View"](#).
3. Disconnect vacuum hose from brake booster. Refer to [EM-179, "Exploded View"](#).
4. Disconnect ground cable.

Engine Room RH

1. Disconnect all clips and connectors of the engine room harness from engine side.
 2. Disconnect fuel feed hose and EVAP service port hose. Refer to [EM-182, "Exploded View"](#).
- CAUTION:**
Fit plugs onto disconnected hoses to prevent fuel leakage.
3. Remove reservoir tank of power steering oil pump and piping from vehicle, and temporarily secure them on engine. Refer to [ST-48, "VK50VE : Exploded View"](#).
- CAUTION:**
When temporarily securing, keep the reservoir tank upright to avoid fluid leakage.

ENGINE ASSEMBLY

[VK50VE]

< UNIT REMOVAL AND INSTALLATION >

Vehicle Inside

Follow the procedure below to disconnect engine room harness connectors at passenger room side, and temporarily secure them on engine.

1. Remove glove box assembly and instrument assist lower panel. Refer to [IP-11, "Exploded View"](#).
2. Disconnect engine room harness connectors at unit sides and other locations.
3. Disengage intermediate fixing point. Pull out engine room harnesses to engine room side, and temporarily secure them on engine.

CAUTION:

- **When pulling out harnesses, take care not to damage harnesses and connectors.**
- **After temporarily securing, cover connectors with vinyl or similar material to protect against adhesion of foreign materials.**

Vehicle Underbody

1. Remove A/T fluid cooler hoses and power steering oil pump oil cooler hoses.
 - Install plug to avoid leakage of A/T fluid and power steering fluid.
2. Disconnect ground cable from exhaust manifold cover (bank 2).
3. Disconnect heated oxygen sensor 2 harness.
4. Remove three way catalyst and exhaust front tube. Refer to [EM-205, "Exploded View"](#) and [EX-10, "Exploded View"](#).
5. Remove rear propeller shaft. Refer to [DLN-132, "Exploded View"](#).
6. Disconnect lower joint at power steering gear assembly side, and release lower shaft. Refer to [ST-17, "WITHOUT ELECTRIC MOTOR : Exploded View"](#) or [ST-20, "WITH ELECTRIC MOTOR : Exploded View"](#).
7. Disengage A/T control rod at A/T shift selector side. Then, temporarily secure it on the transmission assembly, so that it does not sag. Refer to [TM-187, "Exploded View"](#).
8. Preparation for the separation work of transaxle is as per the following:
 - Remove rear plate cover from oil pan (upper). Then remove bolts fixing drive plate to torque converter. Refer to [EM-188, "Exploded View"](#).
 - Remove transmission joint bolts that pierce at oil pan (upper) lower rear side. Refer to [EM-188, "Exploded View"](#).
9. Remove front stabilizer connecting rod. Refer to [FSU-36, "Exploded View"](#).
10. Remove front wheel sensor for ABS from steering knuckle. Refer to [BRC-133, "FRONT WHEEL SENSOR : Exploded View"](#).
11. Remove brake caliper assembly with piping connected from steering knuckle. Temporarily secure it on the vehicle side with a rope to avoid load on it. Refer to [BR-47, "BRAKE CALIPER ASSEMBLY \(4 PISTON TYPE\) : Exploded View"](#).
12. Separate upper link from steering knuckle. Refer to [FSU-32, "Exploded View"](#).
13. Separate shock absorber from transverse link. Refer to [FSU-32, "Exploded View"](#).

Removal Work

1. Use a manual lift table caddy (commercial service tool) or an equivalently rigid tool such as a transmission jack. Securely support bottom of suspension member and the transmission assembly.

CAUTION:

Use a piece of wood or a similar item as the supporting surface to secure a completely stable condition.

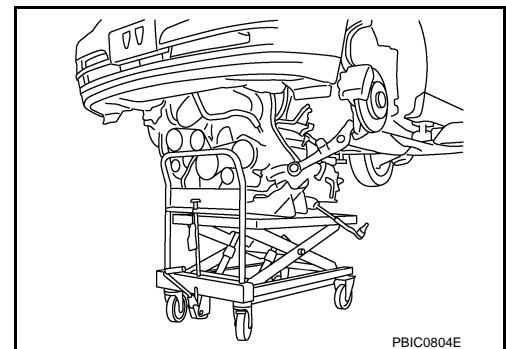

2. Loosen rear engine mounting member mounting bolts.
3. Loosen front suspension member mounting bolts. Refer to [FSU-37, "Exploded View"](#).
4. Carefully lower jack, or raise lift, to remove the engine, the transmission assembly and front suspension member. When performing work, observe the following caution items:

CAUTION:

ENGINE ASSEMBLY

< UNIT REMOVAL AND INSTALLATION >

[VK50VE]

- Confirm there is no interference with the vehicle.
- Check that all connection points have been disconnected.
- Keep in mind that the center of gravity of the vehicle changes. If necessary, use jack(s) to support the vehicle at rear jacking point(s) to prevent it from falling off the lift.

Separation Work

1. Install engine slingers into front of cylinder head (bank 1) and rear of cylinder head (bank 2).

1 : Engine front slinger (bank 1)

2 : Engine rear slinger (bank 2)

← : Engine front

Slinger bolts:

: 45.0 N·m (4.6 kg·m, 33 ft·lb)

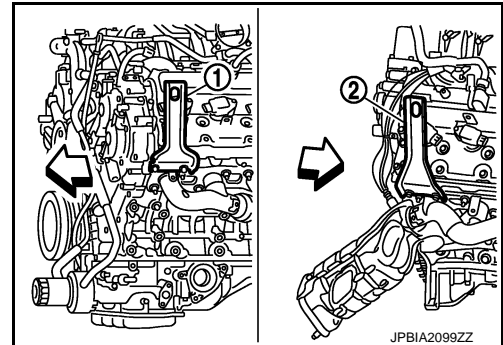

2. Hang the lifting hook of a two-point engine lifter (commercial service tool) (A) from the front and rear engine slingers to hoist engine and flywheel housing assembly.
 - For the flywheel housing side, use a webbing slinger (B) or an equivalent to hoist the assembly horizontally.

CAUTION:

Always hoist the engine by using a two-point engine lifter (i.e. hoisting the front and rear slingers from one point in the air), or the rocker cover and parts around the engine may be damaged due to the fall of the engine slinger.

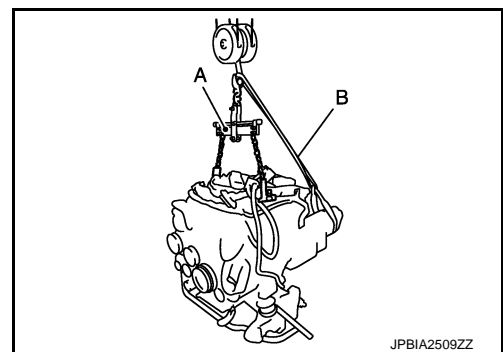

3. Remove power steering oil pump from engine side. Refer to [ST-40, "VK50VE : Exploded View"](#).
4. Remove engine mounting insulators (RH and LH) under side nuts with power tool.
5. Lift with hoist and separate the engine, transmission, transfer and front final drive assembly from front suspension member.
CAUTION:
 - Before and during this lifting, always check that any harnesses are left connected.
 - Never damage engine mounting insulator and avoid oil/grease smearing or spills onto engine mounting insulator.
6. Remove alternator. Refer to [CHG-28, "VK50VE : Exploded View"](#).
7. Separate the engine from the transmission assembly. Refer to [TM-384, "Exploded View"](#).
8. Remove front propeller shaft. Refer to [DLN-109, "VK50VE : Exploded View"](#).
9. Remove the front final drive assembly from oil pan (upper). Refer to [DLN-149, "VK50VE : Exploded View"](#).
10. Remove each engine mounting insulator and each engine mounting bracket from the engine with power tool.

INSTALLATION

Note the following item, and install in the reverse order of removal.

- Do not allow engine mounting insulator to be damage and careful no engine oil gets on it.
- For a location with a positioning pin, insert it securely into hole of matching part.
- For a part with a specified installation orientation, refer to component figure in [EM-196, "Exploded View"](#).

ENGINE ASSEMBLY

[VK50VE]

< UNIT REMOVAL AND INSTALLATION >

- When installing engine mounting bracket (RH and LH) on cylinder block, tighten two upper bolts (A) first. Then tighten two lower bolts (B).

⇐ : Engine front

NOTE:

This figure shows an example of bank 2.

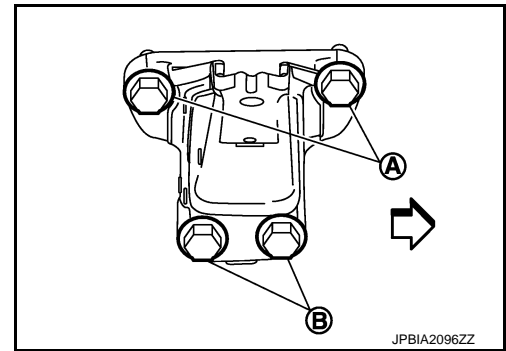

- When installing engine mounting bracket (rear) on transfer, tighten two upper bolts (B) first. Then tighten two lower bolts (C).

A : Rear view

- When installing engine mounting insulator (rear) on engine mounting bracket (rear), tighten upper bolts (D) first. Then tighten lower bolts (E).

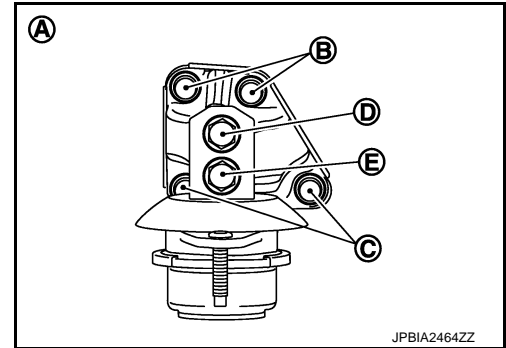

- Tighten rear engine mounting member bolts in numerical order as shown in the figure.

⇐ : Vehicle front

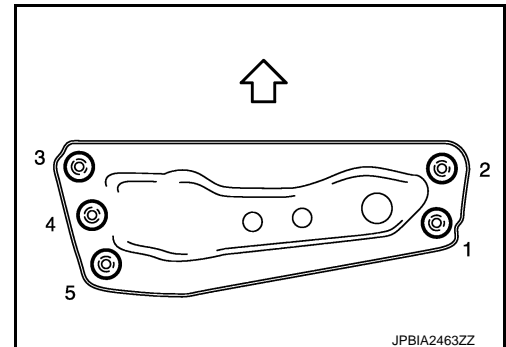

- Check that all engine mounting insulators are seated properly, then tighten mounting nuts and bolts.

Inspection

INFOID:000000003733441

INSPECTION AFTER INSTALLATION

Inspection for Leakage

The following are procedures for checking fluid leakage, lubricant leakage.

- Before starting engine, check oil/fluid levels including engine coolant and engine oil. If any are less than the required quantity, fill them to the specified level. Refer to [MA-12. "Fluids and Lubricants"](#).
- Follow the procedure below to check for fuel leakage.
 - Turn ignition switch to the "ON" position (with engine stopped). With fuel pressure applied to fuel piping, check for fuel leakage at connection points.
 - Start engine. With engine speed increased, check again for fuel leakage at connection points.
- Run engine to check for unusual noise and vibration.

NOTE:

If hydraulic pressure inside chain tensioner drops after removal/installation, slack in guide may generate a pounding noise during and just after the engine start. However, this does not indicate a malfunction. The noise will stop after hydraulic pressure rises.

- Warm up engine thoroughly to check that there is no leakage of fuel, or any oil/fluids including engine oil and engine coolant.
- Bleed air from lines and hoses of applicable lines, such as in cooling system.

ENGINE ASSEMBLY

< UNIT REMOVAL AND INSTALLATION >

[VK50VE]

- After cooling down engine, again check oil/fluid levels including engine oil and engine coolant. Refill them to the specified level, if necessary.

A

Summary of the inspection items:

Items	Before starting engine	Engine running	After engine stopped
Engine coolant	Level	Leakage	Level
Engine oil	Level	Leakage	Level
Other oils and fluids*	Level	Leakage	Level
Fuel	Leakage	Leakage	Leakage

EM

C

D

E

F

G

H

I

J

K

L

M

N

O

P

* Transmission/transaxle/CVT fluid, power steering fluid, brake fluid, etc.

UNIT DISASSEMBLY AND ASSEMBLY

ENGINE STAND SETTING

Setting

INFOID:000000003733442

NOTE:

Explained here is how to disassemble with engine stand supporting transmission surface. When using a different type of engine stand, note the difference in the steps, etc.

1. Remove the engine assembly from the vehicle. Refer to [EM-196, "Exploded View"](#).
2. Remove crankshaft pulley. Refer to [EM-194, "FRONT OIL SEAL : Removal and Installation"](#).

NOTE:

The drive plate is fixed with a ring gear stopper [SST: KV10119200 (J-49277)]. Loosen the crankshaft pulley mounting bolts before installing the engine stand.

3. Remove the parts that may restrict installation of engine to a widely used engine stand.
 - Fix crankshaft with a ring gear stopper [SST: KV10119200 (J-49277)]. Loosen drive plate mounting bolt with power tool.
 - Check for deformation or damage of drive plate. Refer to [EM-265, "Inspection"](#).

NOTE:

The procedure is described assuming that you use a widely used engine stand holding the surface, to which transmission is installed.

4. Remove pilot converter using the pilot bushing puller (commercial service tool), if necessary.
5. Lift the engine with hoist to install it onto the widely used engine stand.

CAUTION:

Use an engine stand that has a load capacity [240 kg (529 lb) or more] large enough for supporting the engine weight.

- If the load capacity of the stand is not adequate, remove the following parts beforehand to reduce the potential risk of overturning the stand.
 - Remove intake manifold. Refer to [EM-179, "Exploded View"](#).
 - Remove fuel injector and fuel tube assembly. Refer to [EM-182, "Exploded View"](#).
 - Remove ignition coil. Refer to [EM-191, "Exploded View"](#).
 - Remove rocker cover. Refer to [EM-191, "Exploded View"](#).
 - Remove exhaust manifold. Refer to [EM-205, "Exploded View"](#).
 - Other removable brackets.

NOTE:

The figure shows an example of widely used engine stand (A) that can hold mating surface of transmission with drive plate removed.

CAUTION:

Before removing the hanging chains, check the engine stand is stable and there is no risk of overturning.

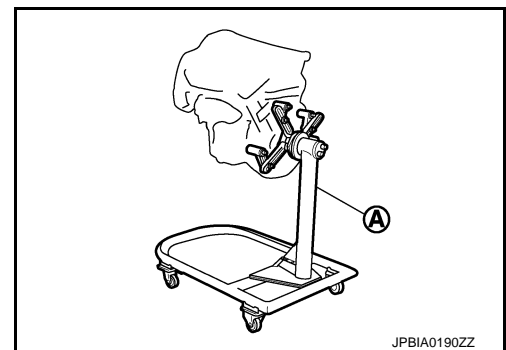

6. Drain engine oil. Refer to [LU-26, "Draining"](#).

ENGINE STAND SETTING

< UNIT DISASSEMBLY AND ASSEMBLY >

[VK50VE]

7. Drain engine coolant by removing water drain plug (3) from both sides of the cylinder block as shown in the figure.

- 1 : Washer
- 2 : Plug
- 4 : Plug
- 5 : Washer
- ← : Engine front

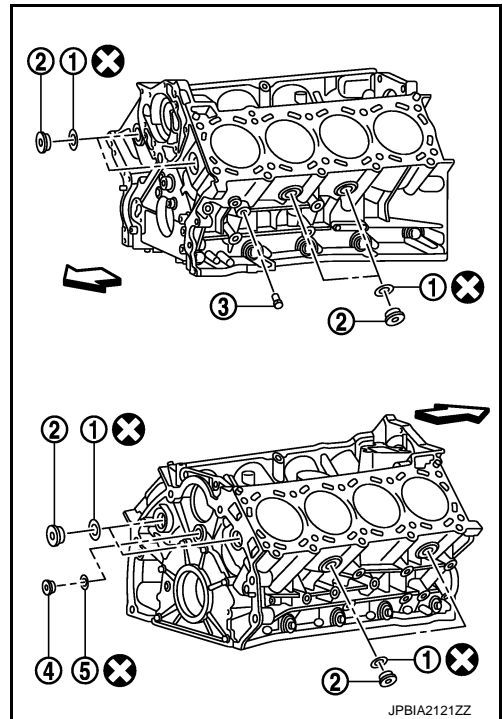

A

EM

C

D

E

F

G

H

I

J

K

L

M

N

O

P

ENGINE UNIT

Disassembly

INFOID:000000003733443

1. Remove intake manifold. Refer to [EM-179, "Exploded View"](#).
2. Remove exhaust manifold. Refer to [EM-205, "Exploded View"](#).
3. Remove oil pan (lower). Refer to [EM-188, "Exploded View"](#).
4. Remove ignition coil, spark plug and rocker cover. Refer to [EM-191, "Exploded View"](#).
5. Remove timing chain. Refer to [EM-212, "Exploded View"](#).
6. Remove camshaft (EXH) and VVEL ladder assembly. Refer to [EM-227, "Exploded View"](#).
7. Remove cylinder head. Refer to [EM-245, "Exploded View"](#).

Assembly

INFOID:000000003733444

Assemble in the reverse order of disassembly.

EXHAUST MANIFOLD AND THREE WAY CATALYST

< UNIT DISASSEMBLY AND ASSEMBLY >

[VK50VE]

EXHAUST MANIFOLD AND THREE WAY CATALYST

Exploded View

INFOID:000000003733423

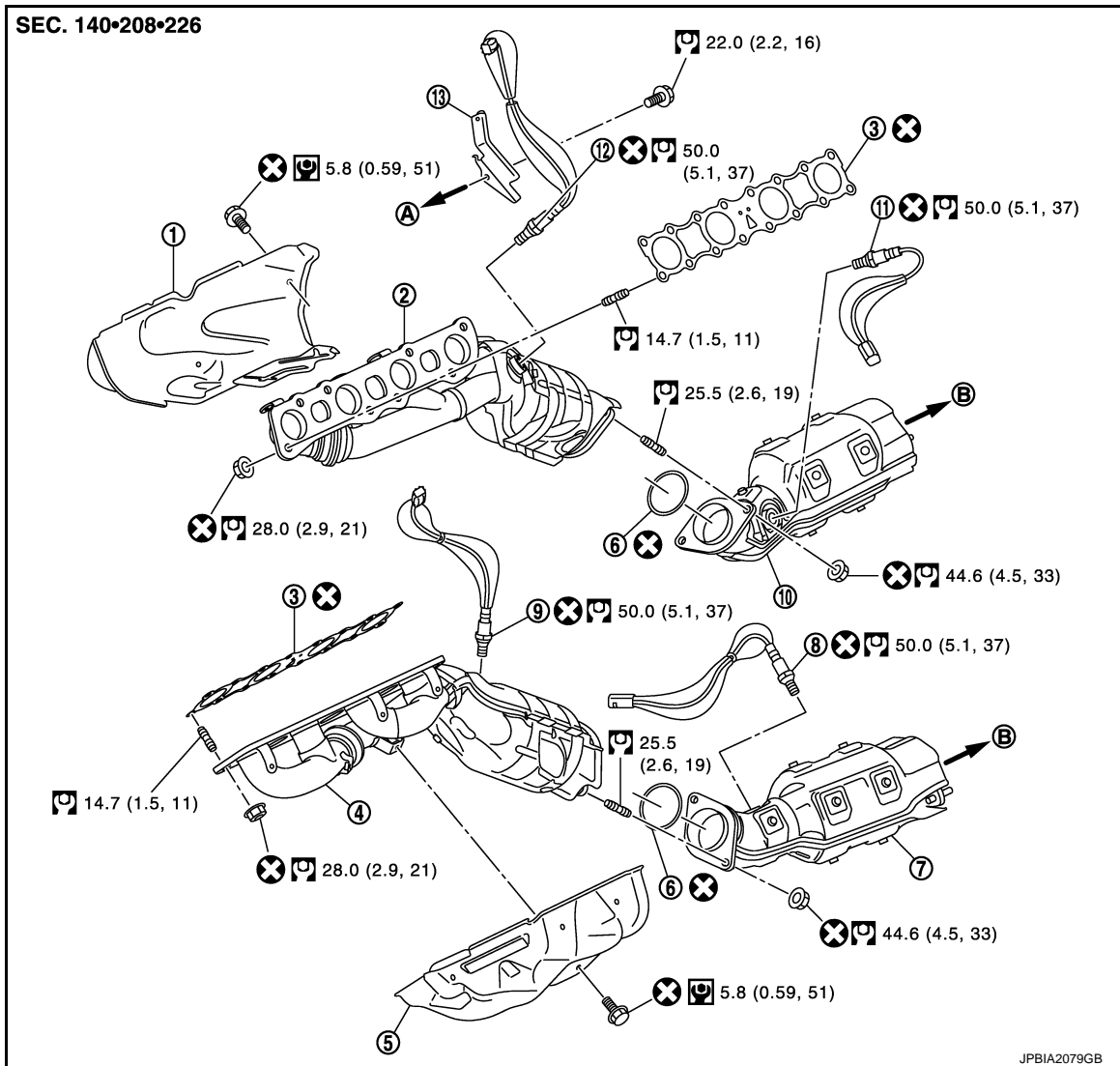

- | | | |
|------------------------------------|-------------------------------------|--------------------------------------|
| 1. Exhaust manifold cover (bank 2) | 2. Exhaust manifold (bank 2) | 3. Gasket |
| 4. Exhaust manifold (bank 1) | 5. Exhaust manifold cover (bank 1) | 6. Gasket |
| 7. Three way catalyst (bank 1) | 8. Heated oxygen sensor 2 (bank 1) | 9. Air fuel ratio sensor 1 (bank 1) |
| 10. Three way catalyst (bank 2) | 11. Heated oxygen sensor 2 (bank 2) | 12. Air fuel ratio sensor 1 (bank 2) |
| 13. Harness bracket | | |

A. To cylinder head (bank 2) B. To exhaust front tube

Refer to [GI-4, "Components"](#) for symbols in the figure.

Disassembly and Assembly

INFOID:000000003733424

DISASSEMBLY

1. Remove heated oxygen sensor 2.

CAUTION:

Heated oxygen sensor 2 is not reusable. Never remove heated oxygen sensor 2 unless this is required.

EXHAUST MANIFOLD AND THREE WAY CATALYST

< UNIT DISASSEMBLY AND ASSEMBLY >

[VK50VE]

- Using the heated oxygen sensor wrench [SST: KV10114400 (J-38365)] (A), remove heated oxygen sensor 2 (1).

NOTE:

- The heated oxygen sensor 2 is removable under vehicle-mounted condition.
- The figure shows an example of bank 1.

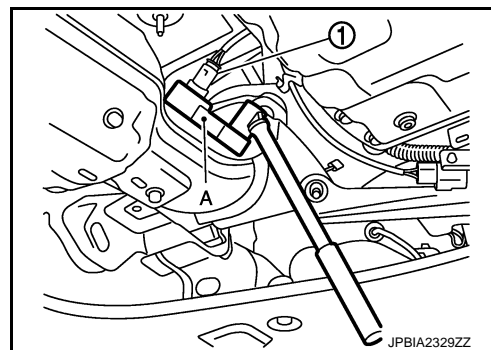

2. Remove three way catalyst (bank 1 and bank 2).

3. Remove air fuel ratio sensor 1 as per the following:

CAUTION:

Air fuel ratio sensor 1 is not reusable. Never remove air fuel ratio sensor 1 unless this is required.

- Using the heated oxygen sensor wrench [SST: KV10114400 (J-38365)], remove air fuel ratio sensor 1.

NOTE:

The air fuel ration sensor 1 is removable under vehicle-mounted condition.

4. Remove exhaust manifold.

- Loosen nuts in the reverse order of figure to remove exhaust manifold with power tool.

A : Bank 1

B : Bank 2

⇐ : Engine front

NOTE:

Disregard No. 9 to No. 12 when loosening.

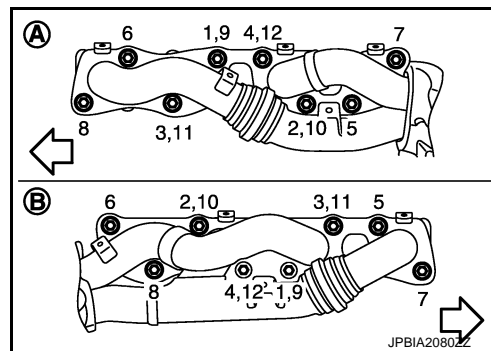

5. Remove exhaust manifold gaskets.

CAUTION:

Cover engine openings to avoid entry of foreign materials.

ASSEMBLY

Note the following item, and install in the reverse order of removal.

Exhaust Manifold Gasket

- Install exhaust manifold gasket in directional shown in the figure.

A : Triangle press

⇐ : Above

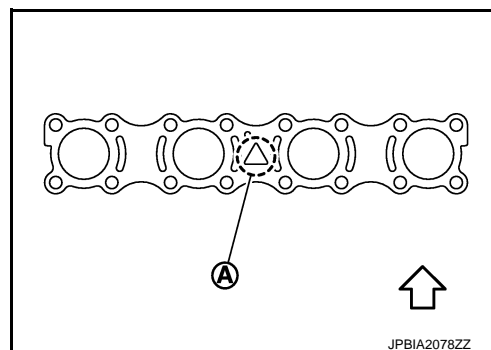

Exhaust Manifold

EXHAUST MANIFOLD AND THREE WAY CATALYST

< UNIT DISASSEMBLY AND ASSEMBLY >

[VK50VE]

- Tighten mounting nuts in numerical order as shown in the figure.

A : Bank 1
B : Bank 2
⇐ : Engine front

NOTE:

Tighten mounting nuts No. 1 to 4 in two steps. The numerical order No. 9 to 12 shown second steps.

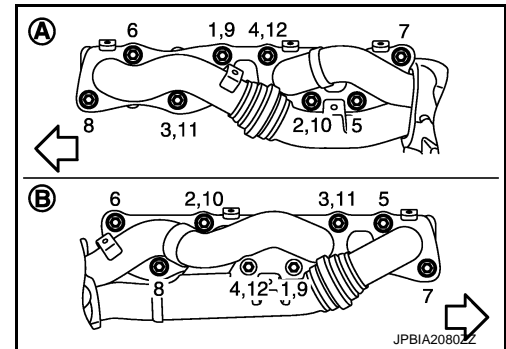

Air Fuel Ratio Sensor 1, Heated Oxygen Sensor 2

CAUTION:

- Before installing a new sensors, clean exhaust system threads using oxygen sensor thread cleaner (commercial service tool: J-43897-18 or J-43897-12), and apply anti-seize lubricant (commercial service tool).
- Sensors are not reusable. Replace them with a new one after removal. When replacing them, handle with care not to impact on them.
- When installing the new sensors, set the heated oxygen sensor wrench [SST: KV10114400(J-38365)] (A) in the hexagonal part to tighten the them.

1 : Heated oxygen sensor 2 (bank 1)

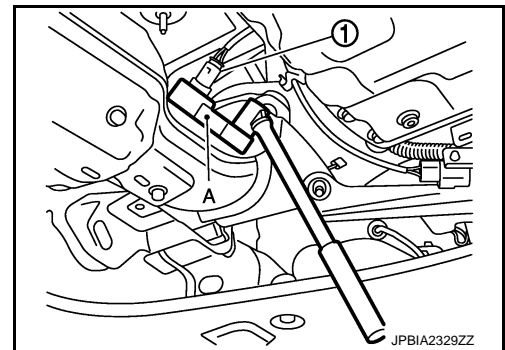

- Never over torque sensors. Doing so may cause damage to the sensors, resulting in "MIL" coming on.

Inspection

INFOID:000000003733425

INSPECTION AFTER DISASSEMBLY

Surface Distortion

- Check the surface distortion of the exhaust manifold mating surface with a straightedge (A) and a feeler gauge (B).

Limit : Refer to [EM-283, "Exhaust Manifold"](#).

- If it exceeds the limit, replace exhaust manifold.

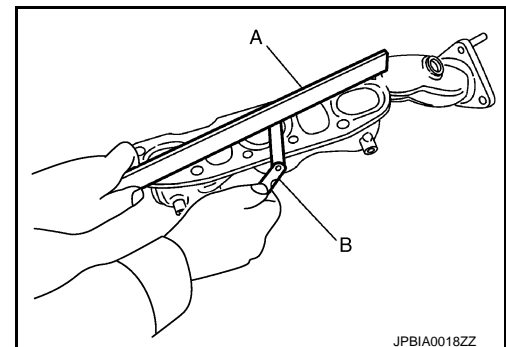

OIL PAN (UPPER)

< UNIT DISASSEMBLY AND ASSEMBLY >

[VK50VE]

OIL PAN (UPPER)

Exploded View

INFOID:000000003733445

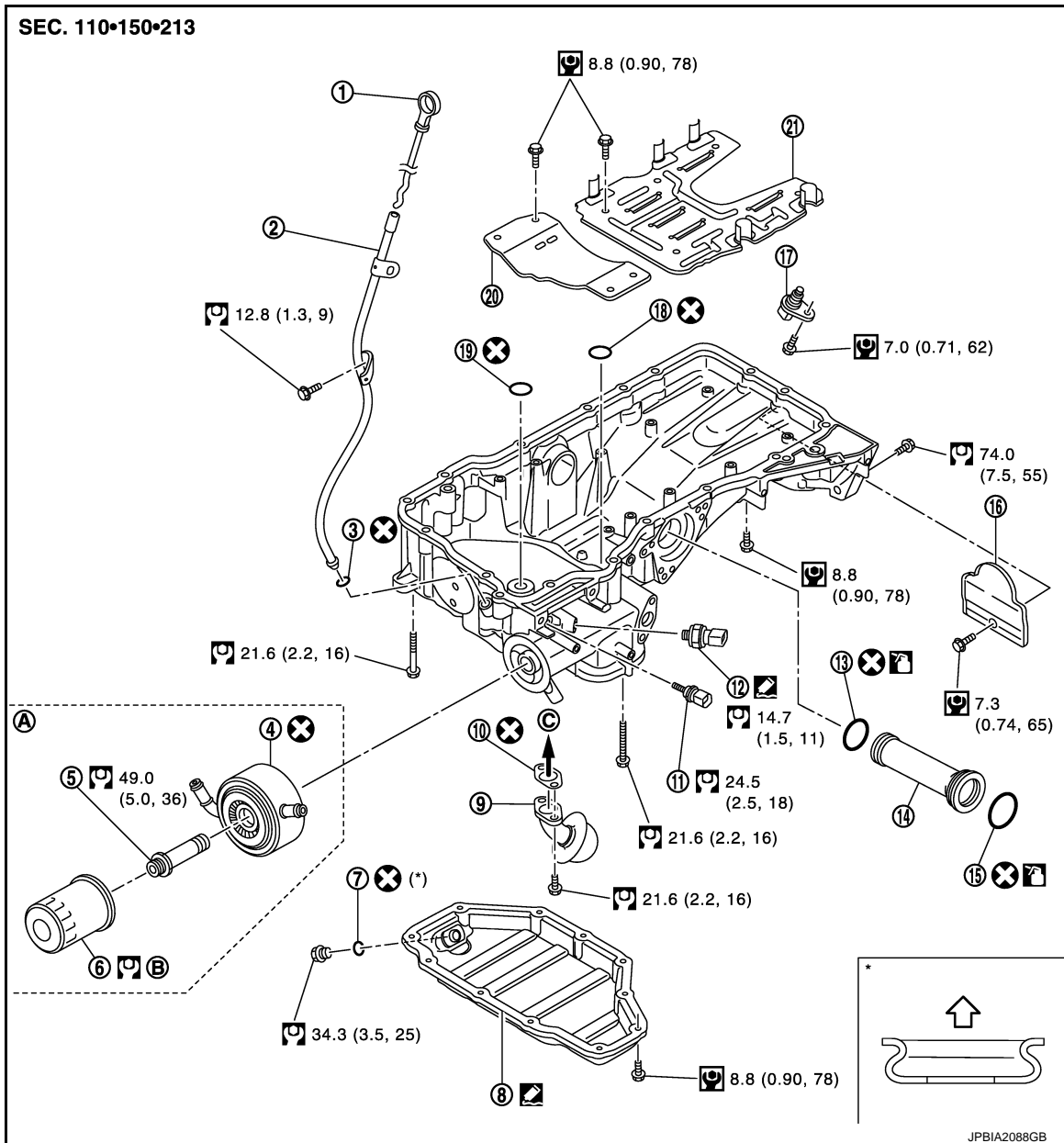

- | | | |
|-----------------------------------|--------------------------------------|-------------------------|
| 1. Oil level gauge | 2. Oil level gauge guide | 3. O-ring |
| 4. Oil cooler | 5. Connector bolt | 6. Oil filter |
| 7. Drain plug washer | 8. Oil pan (lower) | 9. Oil strainer |
| 10. Gasket | 11. Oil temperature sensor | 12. Oil pressure switch |
| 13. O-ring | 14. Axle pipe | 15. O-ring |
| 16. Rear plate cover | 17. Crankshaft position sensor (POS) | 18. O-ring |
| 19. O-ring | 20. Baffle plate | 21. Baffle plate |
| A. Refer to LU-29 | B. Refer to LU-28 | C. Oil pump side |

← : Oil pan side

Refer to [GI-4, "Components"](#) for symbols in the figure.

OIL PAN (UPPER)

< UNIT DISASSEMBLY AND ASSEMBLY >

[VK50VE]

Disassembly and Assembly

INFOID:000000003733446

DISASSEMBLY

WARNING:

To avoid the danger of being scalded, never drain engine oil when engine is hot.

1. Remove oil filter. Refer to [LU-28, "Removal and Installation"](#).
2. Remove oil cooler. Refer to [LU-29, "Exploded View"](#).
3. Remove A/C compressor and A/C compressor bracket. Refer to [HA-94, "Exploded View"](#) and [EM-212, "Exploded View"](#).
4. Remove oil level gauge and oil level gauge guide.
5. Remove oil pressure switch and oil temperature sensor if necessary.
6. Remove rear plate cover.
7. Remove oil pan (lower). Refer to [EM-188, "Exploded View"](#).
8. Remove oil strainer. Refer to [EM-188, "Exploded View"](#).
9. Remove oil pan (upper) as per the following:
 - a. Loosen mounting bolts in the reverse order as shown in the figure with power tool to remove.

⇐ : Engine front

NOTE:

Disregard No. 12, 17 when loosening.

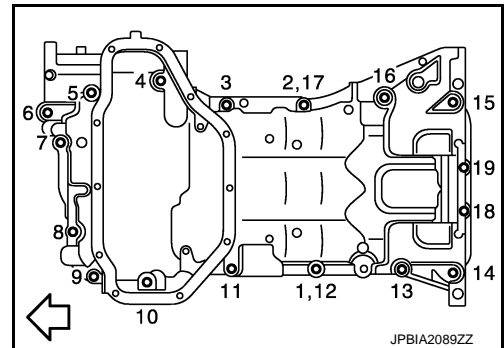

- b. Insert a suitable tool into the notch at oil pan (upper) (1) as shown.
 - Pry off case by moving a suitable tool.

⇐ : Engine front

CAUTION:

Be careful not to damage the mating surfaces.

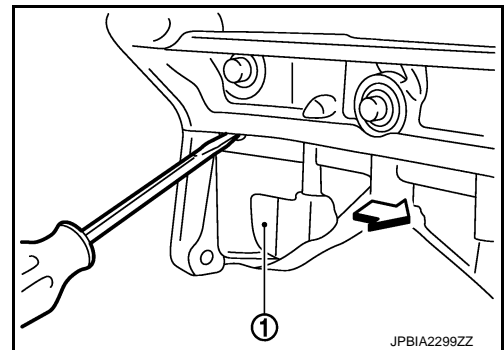

10. Remove O-ring from bottom of cylinder block and oil pump.
11. Remove baffle plate, if necessary.
12. Remove axle pipe from oil pan (upper), if necessary.
 - Pull axle pipe from oil pan (upper) using a suitable drift.

ASSEMBLY

1. Install axle pipe (1) to oil pan (upper), if removed.

2 : O-ring

3 : O-ring (with identification paint)

A : Front final drive side

B : Drive shaft (LH) side

- Lubricate O-ring groove of axle pipe, O-ring, and O-ring joint of oil pan with new engine oil.
- Install axle pipe to oil pan (upper) from drive shaft (LH) side.

CAUTION:

Insert it with care to prevent O-ring from sliding.

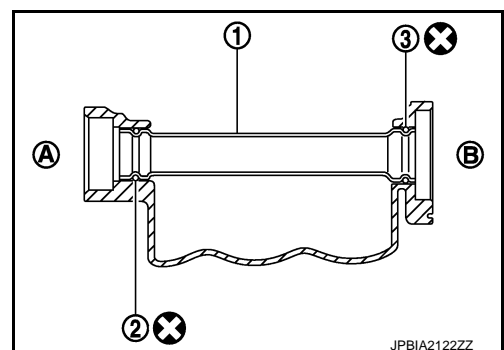

OIL PAN (UPPER)

[VK50VE]

< UNIT DISASSEMBLY AND ASSEMBLY >

2. Install oil pan (upper) as per the following:
 - a. Use a scraper (A) to remove old liquid gasket from mating surfaces.
 - Also remove the old liquid gasket from mating surface of cylinder block.
 - Remove old liquid gasket from the bolt holes and threads.

CAUTION:

Never scratch or damage the mating surfaces when cleaning off old liquid gasket.

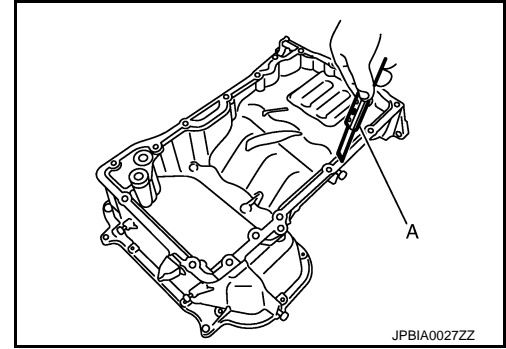

- b. Install new O-rings on the bottom of cylinder block and oil pump.
- c. Apply a continuous bead of liquid gasket with tube presser (commercial service tool) to the cylinder block mating surfaces of oil pan (upper) to a limited portion as shown in the figure.

- a : 5.5 - 7.5 mm (0.217 - 0.295 in)
 b : ϕ 4.0 - 5.0 mm (0.157 - 0.197 in)

← : Engine front

Use Genuine RTV Silicone Sealant or an equivalent. Refer to [GI-15, "Recommended Chemical Products and Sealants"](#).

CAUTION:

Attaching must be done within 5 minutes after coating.

- d. Tighten mounting bolts in numerical order as shown in the figure.

← : Engine front

CAUTION:

Install avoiding misalignment of O-rings.

NOTE:

Tighten mounting bolts No. 1 and 2 in two steps. The numerical order No. 12 and 17 shown second steps.

- There are three types of mounting bolts. Refer to the following for locating bolts.

- M6 × 30 mm (1.18 in) : 18, 19**
M8 × 100 mm (3.94 in) : 3, 4, 5, 7, 10, 11, 14, 15
M8 × 45 mm (1.77 in) : Except the above

- e. Tighten transmission joint bolts.
- f. Install rear plate cover.
3. Install oil strainer.
4. Install oil pan (lower). Refer to [EM-189, "Removal and Installation"](#).
5. Install in the reverse order of removal.

NOTE:

At least 30 minutes after oil pan is installed, pour engine oil.

Inspection

INFOID:000000003733447

INSPECTION AFTER DISASSEMBLY

Clean oil strainer if any object is attached.

INSPECTION AFTER ASSEMBLY

1. Check the engine oil level and adjust engine oil. Refer to [LU-25, "Inspection"](#).

OIL PAN (UPPER)

< UNIT DISASSEMBLY AND ASSEMBLY >

[VK50VE]

2. Start engine, and check there is no leakage of engine oil.
3. Stop engine and wait for 15 minutes.
4. Check the engine oil level again. Refer to [LU-25. "Inspection"](#).

A

EM

C

D

E

F

G

H

I

J

K

L

M

N

O

P

TIMING CHAIN

< UNIT DISASSEMBLY AND ASSEMBLY >

[VK50VE]

TIMING CHAIN

Exploded View

INFOID:000000003733434

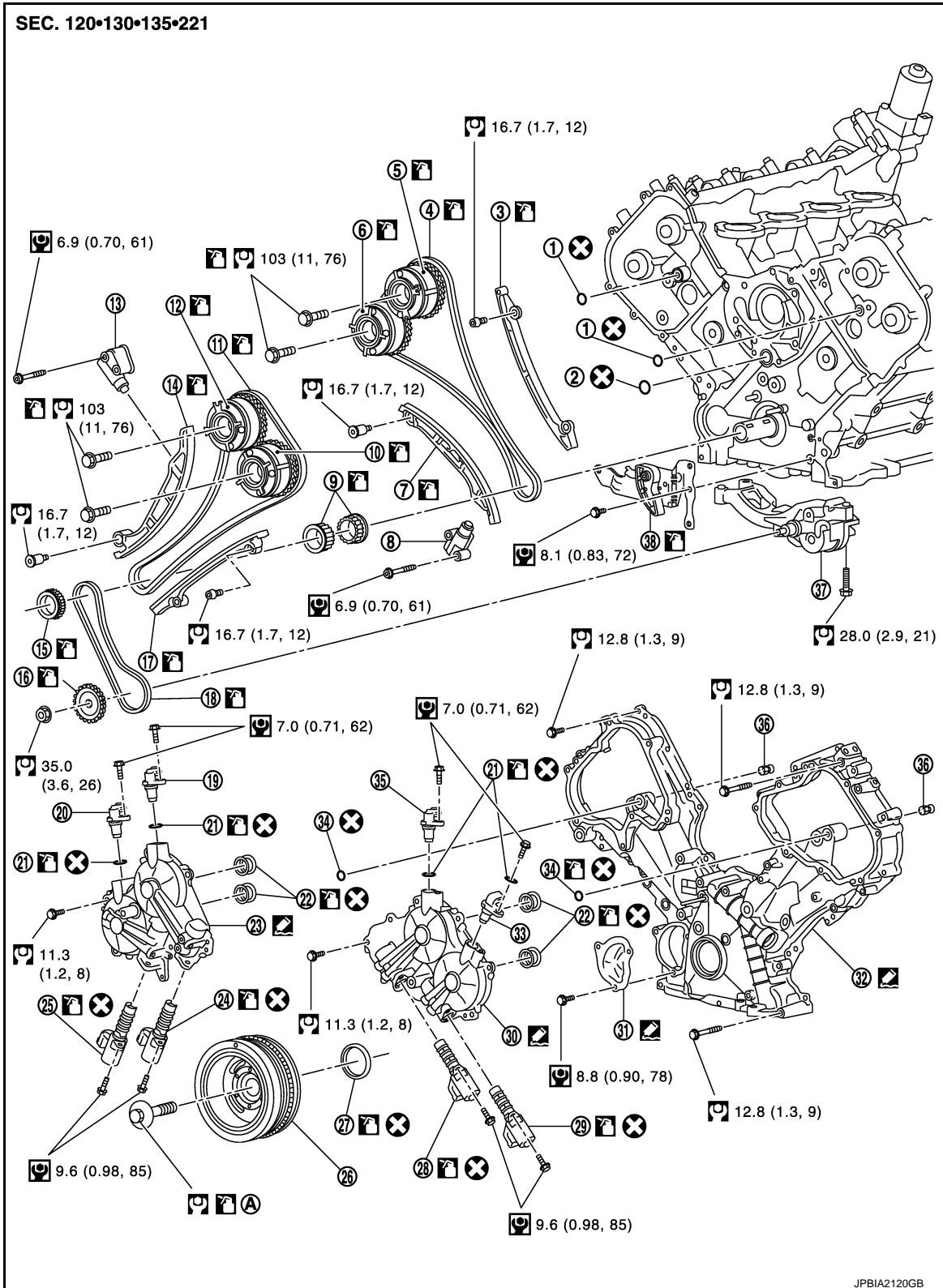

JPBIA2120GB

- | | | |
|--------------------------|-------------------------------------|-------------------------------------|
| 1. O-ring | 2. O-ring | 3. Tension guide (bank 2) |
| 4. Timing chain (bank 2) | 5. Camshaft sprocket (INT) (bank 2) | 6. Camshaft sprocket (EXH) (bank 2) |
| 7. Slack guide (bank 2) | 8. Timing chain tensioner (bank 2) | 9. Crankshaft sprocket |

TIMING CHAIN

< UNIT DISASSEMBLY AND ASSEMBLY >

[VK50VE]

- | | | |
|--|--|--|
| 10. Camshaft sprocket (EXH) (bank 1) | 11. Timing chain (bank 1) | 12. Camshaft sprocket (INT) (bank 1) |
| 13. Timing chain tensioner (bank 1) | 14. Slack guide (bank 1) | 15. Oil pump sprocket (crankshaft side) |
| 16. Oil pump sprocket (oil pump side) | 17. Tension guide (bank 1) | 18. Oil pump drive chain |
| 19. Camshaft position sensor (INT) (bank 2) | 20. Camshaft position sensor (EXH) (bank 2) | 21. O-ring |
| 22. Seal ring | 23. Valve timing control cover (bank 2) | 24. Intake valve timing control solenoid valve (bank 2) |
| 25. Exhaust valve timing control solenoid valve (bank 2) | 26. Crankshaft pulley | 27. Front oil seal |
| 28. Intake valve timing control solenoid valve (bank 1) | 29. Exhaust valve timing control solenoid valve (bank 1) | 30. Valve timing control cover (bank 1) |
| 31. Timing chain tensioner cover | 32. Front cover | 33. Camshaft position sensor (EXH) (bank 1) |
| 34. O-ring | 35. Camshaft position sensor (INT) (bank 1) | 36. Oil filter (for valve timing control solenoid valve) |
| 37. Oil pump | 38. Oil pump drive chain tensioner | |

A. Refer to [EM-213](#)

Refer to [GI-4, "Components"](#) for symbol marks in the figure.

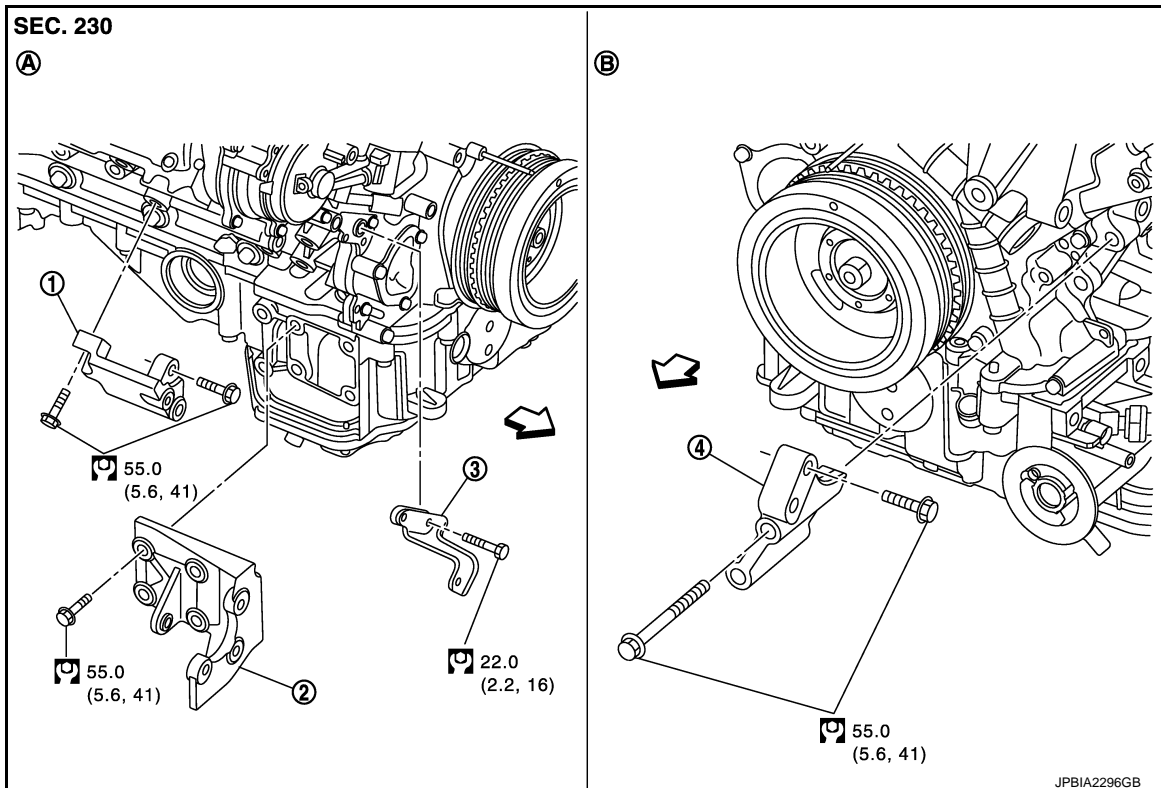

- | | | |
|-----------------------|--------------------------------|-----------------------|
| 1. Alternator bracket | 2. Power steering pump bracket | 3. Alternator support |
|-----------------------|--------------------------------|-----------------------|

- | | | |
|---------------------------|--|--|
| 4. A/C compressor bracket | | |
|---------------------------|--|--|

- | | |
|---------------|---------------|
| A. Right side | B. Front side |
|---------------|---------------|

↶ : Engine front

Refer to [GI-4, "Components"](#) for symbol marks in the figure.

Disassembly and Assembly

INFOID:000000003733435

DISASSEMBLY

1. Remove auto tensioners and idler pulley. Refer to [EM-176, "Exploded View"](#).
2. Remove oil level gauge and oil level gauge guide. Refer to [EM-212, "Exploded View"](#).
3. Remove alternator bracket and alternator stay.

TIMING CHAIN

< UNIT DISASSEMBLY AND ASSEMBLY >

[VK50VE]

4. Remove camshaft position sensors.

A : Keep free from magnetic materials

CAUTION:

- Handle carefully to avoid dropping and shocks.
- Never disassemble.
- Never allow metal powder to adhere to magnetic part at sensor tip.
- Never place sensors in a location where they are exposed to magnetism.

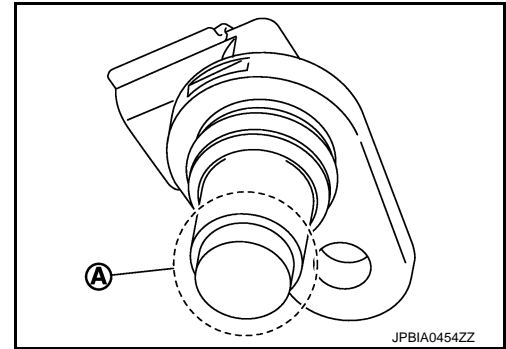

5. Remove valve timing control cover as per the following:
- a. Disconnect valve timing control solenoid valve harness connector.
 - b. Loosen mounting bolts in the reverse order as shown in the figure.

A : Bank 2
B : Bank 1
C : Dowel pin hole

CAUTION:

- Exercise care not to damage mating surfaces.
- Shaft is internally jointed with camshaft sprocket center hole. When removing, keep it horizontal until it is completely disconnected.

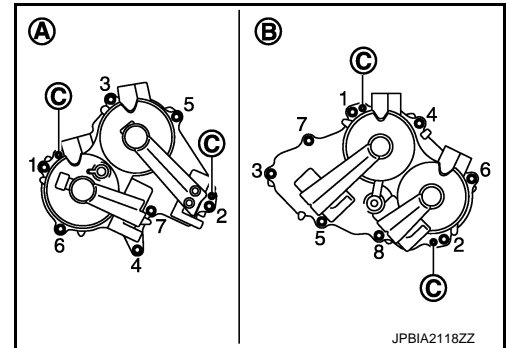

6. Remove valve timing control solenoid valve (INT and EXH), if necessary.

CAUTION:

Valve timing control solenoid valve is not reusable. Never remove it unless required.

7. Remove O-rings (1) from front cover.

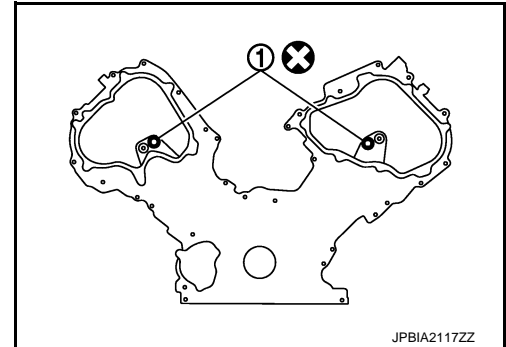

8. Remove rocker cover. Refer to [EM-191, "Exploded View"](#).
9. Obtain No. 1 cylinder at TDC of its compression stroke. Refer to [EM-169, "Inspection"](#).
10. Remove crankshaft pulley. Refer to [EM-194, "FRONT OIL SEAL : Removal and Installation"](#).
11. Remove water pump pulley. Refer to [CO-44, "Exploded View"](#).
12. Remove oil pan (lower) and oil strainer. Refer to [EM-188, "Exploded View"](#).
13. Remove oil pan (upper). Refer to [EM-208, "Exploded View"](#).
14. Remove front cover as per the following:

TIMING CHAIN

[VK50VE]

< UNIT DISASSEMBLY AND ASSEMBLY >

- a. Loosen mounting bolts in reverse order as shown in the figure.
 - b. Insert a suitable tool into the notch at front cover.
 - Pry off case by moving a suitable tool.
- CAUTION:**
- Exercise care not to damage mating surfaces.
 - After removal, handle front cover carefully so it does not tilt, cant, or warp under a load.

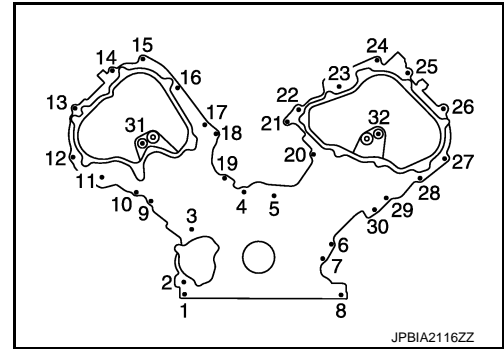

15. Remove front oil seal from front cover using suitable tool.
 - Use screwdriver for removal.

CAUTION:
Be careful not to damage front cover.

16. Remove O-rings (1), (2) from cylinder heads and cylinder block.

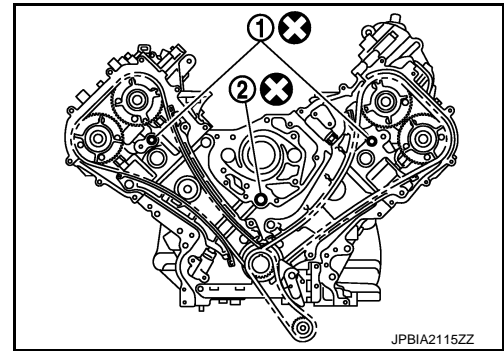

17. Remove oil filter (for valve timing control solenoid valve), if necessary.
18. Remove timing chain tensioner cover from front cover, if necessary.
 - Use seal cutter [SST: KV10111100 (J-37228)] to cut liquid gasket for removal.
19. Remove oil pump drive chain as per the following:
 - a. Push oil pump drive chain tensioner (1).
 - b. Insert a stopper pin (A) into the body hole.

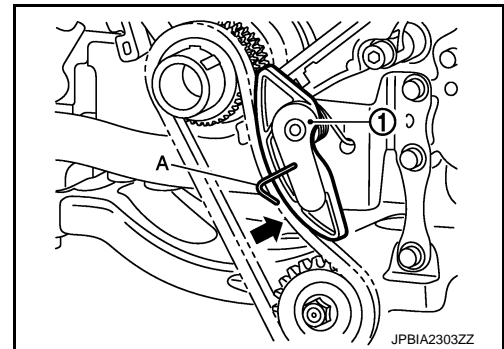

- c. Hold the two flat parts of oil pump shaft, and then loosen the oil pump sprocket (oil pump side) nut.

1 : Oil pump sprocket (oil pump side)

CAUTION:
Secure the oil pump unit shaft with the two flat parts.

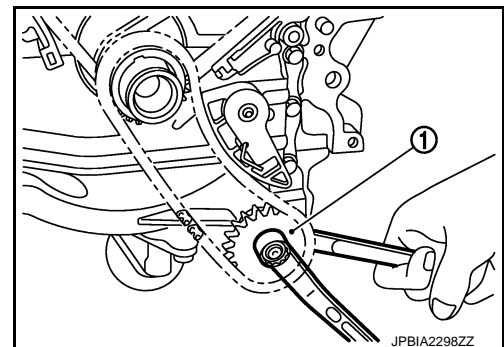

20. Remove oil pump drive chain tensioner.
21. Remove timing chain tensioner (bank 1) as per the following:

TIMING CHAIN

< UNIT DISASSEMBLY AND ASSEMBLY >

[VK50VE]

NOTE:

To remove timing chain and related parts, start with those on bank 1. The procedure for removing parts on bank 2 is omitted because it is the same as that for bank 1.

- a. Push both sides of spring (A) against spring tension, and then press in plunger with a slack guide (2).

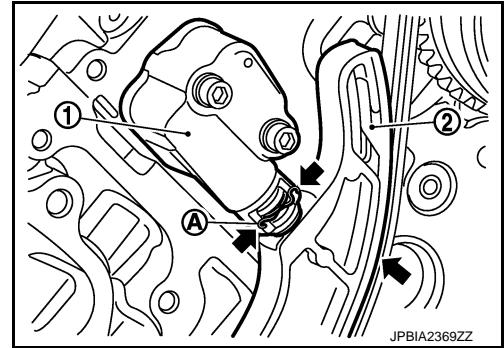

1 : Timing chain tensioner (bank 1)

- b. Insert a stopper pin (A) into the body hole, and then fix it with the plunger pushed in.

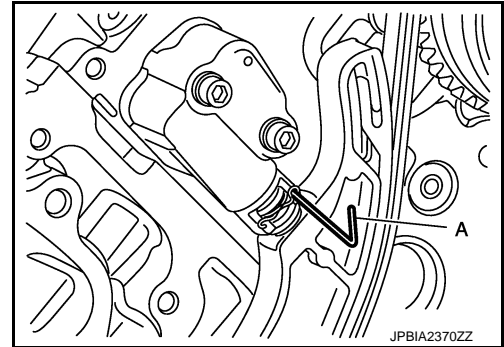

22. Remove tension guide and slack guide.
23. Remove timing chain and crankshaft sprocket.

CAUTION:

After removing timing chain, never turn crankshaft and camshaft separately, or valves will strike the piston head.

24. Remove camshaft sprocket (INT) and (EXH) as per the following:

Exhaust side:

- Secure the hexagonal portion of camshaft (EXH) using a wrench to loosen mounting bolt. Refer to [EM-227, "Exploded View"](#).

Intake side:

- Secure the hexagonal portion (located in between journal No.1 and journal No. 2) of drive shaft (A) using a wrench (B) to loosen mounting bolt. Refer to [EM-227, "Exploded View"](#).

⇐ : Engine front

NOTE:

The figure shows an example of bank 2.

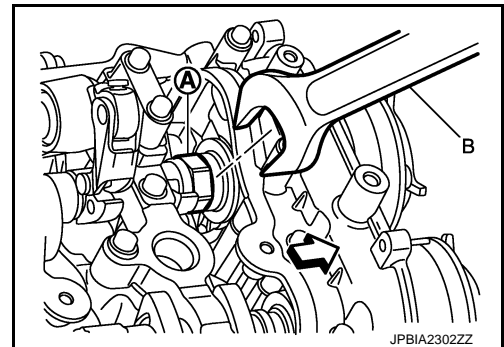

CAUTION:

- Never loosen the mounting bolt by securing anything other than the camshaft (drive shaft) hexagonal portion or with tensioning the timing chain.
- When holding the hexagonal part of camshaft (drive shaft) with a wrench, be careful not to allow the wrench to cause interference with other parts.

TIMING CHAIN

< UNIT DISASSEMBLY AND ASSEMBLY >

[VK50VE]

- Never disassemble camshaft sprocket. [Never loosen bolts (C), (D) as shown in the figure.]

- A : Intake
- B : Exhaust

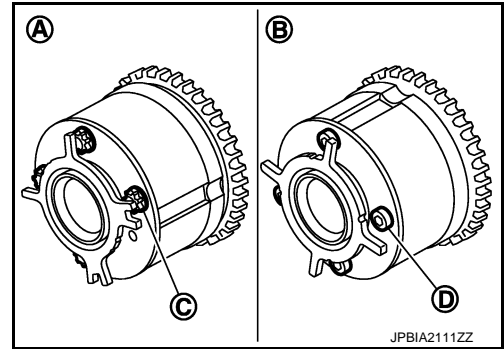

25. Use scraper to remove all traces of old liquid gasket from front cover and opposite mating surfaces.

- Remove old liquid gasket from bolt hole and thread.

- A : Remove old liquid gasket that is stuck
- B : Bolt hole

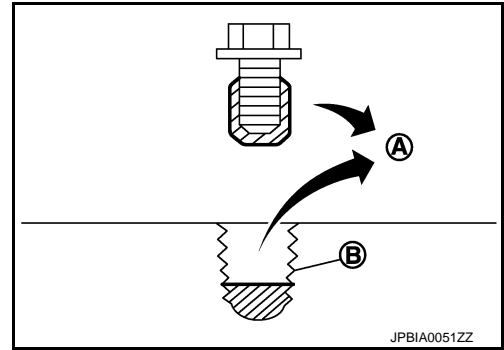

ASSEMBLY

A
EM
C
D
E
F
G
H
I
J
K
L
M
N
O
P

TIMING CHAIN

< UNIT DISASSEMBLY AND ASSEMBLY >

[VK50VE]

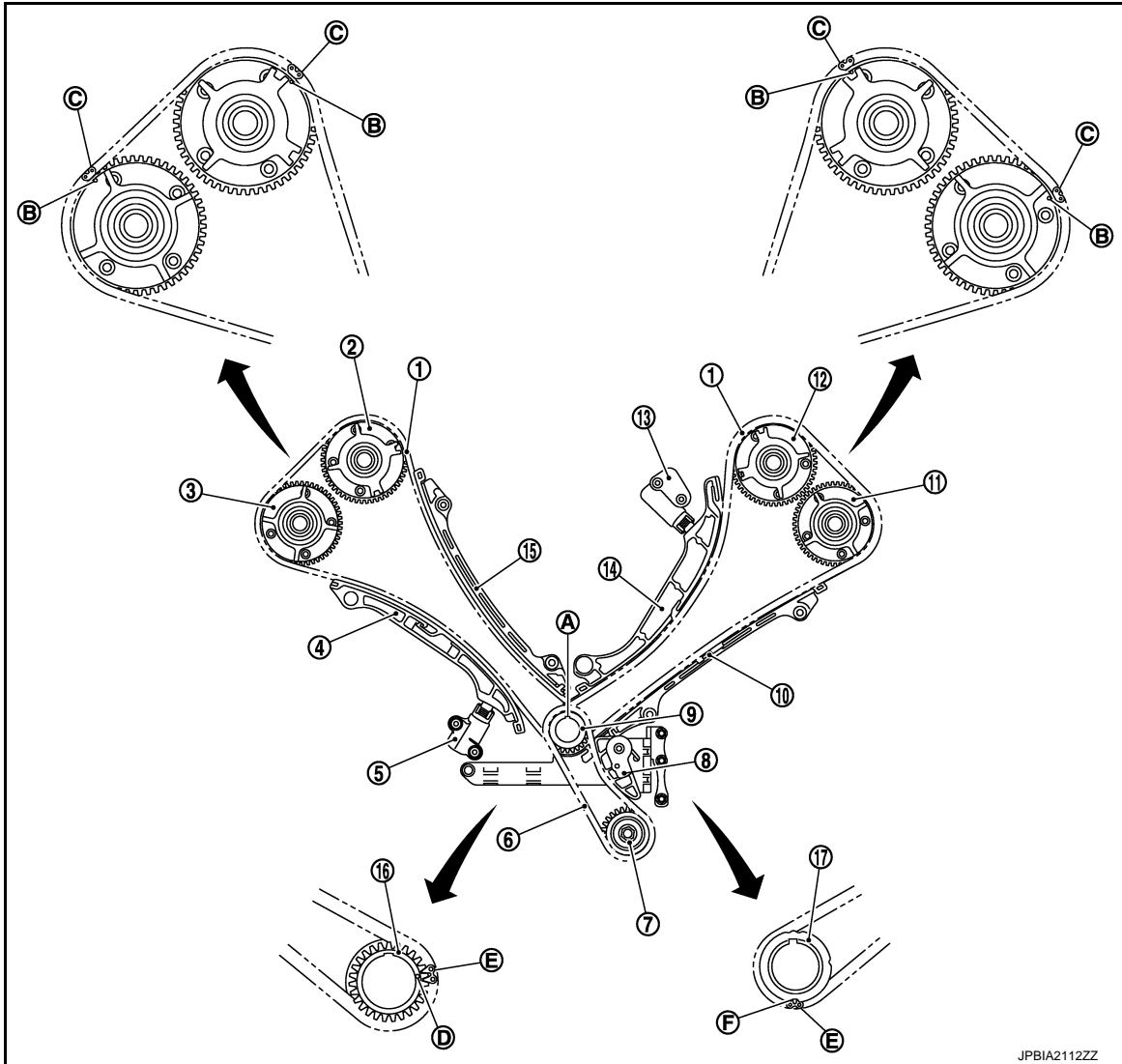

JPBIA2112ZZ

- | | | |
|---------------------------------------|---------------------------------------|--|
| 1. Timing chain | 2. Camshaft sprocket (INT) (bank 2) | 3. Camshaft sprocket (EXH) (bank 2) |
| 4. Slack guide (bank 2) | 5. Timing chain tensioner (bank 2) | 6. Oil pump drive chain |
| 7. Oil pump sprocket (oil pump side) | 8. Oil pump drive chain tensioner | 9. Oil pump sprocket (crankshaft side) |
| 10. Tension guide (bank 1) | 11. Camshaft sprocket (EXH) (bank 1) | 12. Camshaft sprocket (INT) (bank 1) |
| 13. Timing chain tensioner (bank 1) | 14. Slack guide (bank 1) | 15. Tension guide (bank 2) |
| 16. Crankshaft sprocket (bank 2 side) | 17. Crankshaft sprocket (bank 1 side) | |
| A. Crankshaft key | B. Matching mark (outer groove) | C. Matching mark (copper link) |
| D. Matching mark (punched) | E. Matching mark (yellow link) | F. Matching mark (notched) |

NOTE:

- The above figure shows the relationship between the matching mark on each timing chain and that on the corresponding sprocket, with the components installed.
- Parts with an identification mark (R or L) should be installed on the corresponding bank according to the mark.
 - Camshaft sprocket (INT), camshaft sprocket (EXH)
 - Tension guide
 - Slack guide
- To install timing chain and related parts, start with those on bank 2. The procedure for installing parts on bank 1 is omitted because it is the same as that for installation on bank 2.
- There is no matching mark in the oil pump related parts.

TIMING CHAIN

[VK50VE]

< UNIT DISASSEMBLY AND ASSEMBLY >

1. Check that crankshaft key (1) and dowel pin (A) of each camshaft are located as shown in the figure.

Camshaft dowel pin

: At cylinder head upper face side in each bank

Crankshaft key

: Straight up

NOTE:

Though camshaft does not stop at the position as shown in the figure, for the placement of cam nose, it is generally accepted camshaft is placed for the same direction of the figure.

2. Install camshaft sprockets (INT and EXH).
 - Install onto correct side by checking with identification mark (A) on surface.

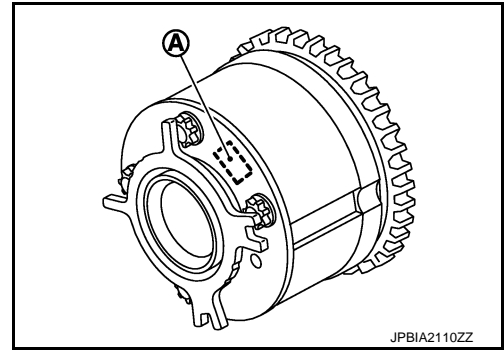
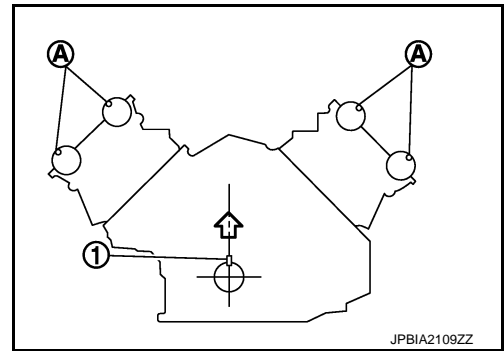

Exhaust side:

- Secure the hexagonal portion of camshaft (EXH) using a wrench to tighten mounting bolt. Refer to [EM-227, "Exploded View"](#).

Intake side:

- Secure the hexagonal portion (located in between journal No.1 and journal No. 2) of drive shaft (A) using a wrench (B) to tighten mounting bolt. Refer to [EM-227, "Exploded View"](#).

⇐ : Engine front

NOTE:

The figure shows an example of bank 2.

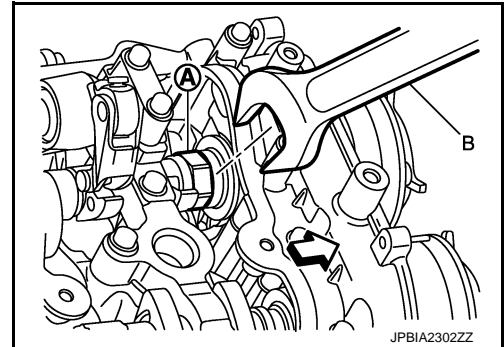

3. Install timing chains as per the following:
 - a. Install crankshaft sprockets for both banks.
 - Install each crankshaft sprocket so that its flange side (the larger diameter side without teeth) (A) faces in the direction shown in the figure.

1 : Crankshaft sprocket (bank 1 side)

2 : Crankshaft sprocket (bank 2 side)

NOTE:

The same parts are used but facing directions are different.

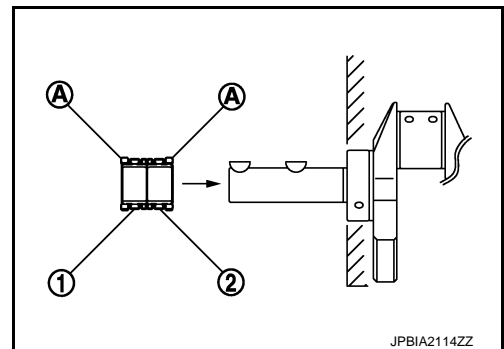

TIMING CHAIN

[VK50VE]

< UNIT DISASSEMBLY AND ASSEMBLY >

b. Install timing chains.

Bank 2 (F):

- Install timing chain so that the matching mark (outer groove) (B) on camshaft sprocket is aligned with the copper link (A) on timing chain, while the matching mark (punched) (C) on crankshaft sprocket is aligned with the yellow link (D) one on timing chain, as shown in the figure.

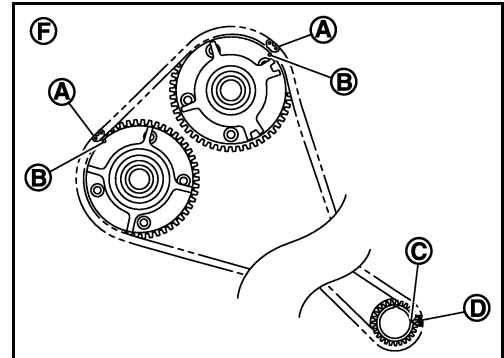

Bank 1 (G):

- Install timing chain so that the matching mark (outer groove) (B) on camshaft sprocket is aligned with the copper link (A) on timing chain, while the matching mark (notched) (E) on crankshaft sprocket is aligned with the yellow link (D) one on timing chain, as shown in the figure.

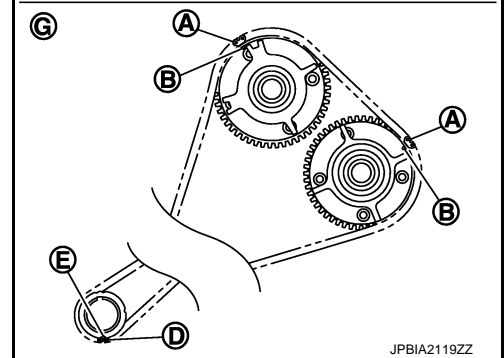

JPBIA2119ZZ

4. Install slack guides and tension guides onto correct side by checking with identification mark (A) on surface.

- 1 : Slack guide (bank 2)
- 2 : Tension guide (bank 2)
- 3 : Slack guide (bank 1)
- 4 : Tension guide (bank 1)

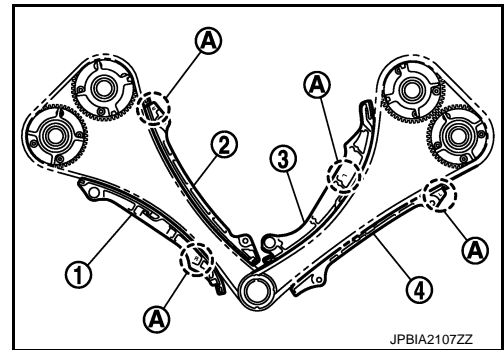

JPBIA2107ZZ

CAUTION:

Never overtighten slack guide mounting bolt (2). It is normal for a gap (A) to exist under the bolt seats when mounting bolt are tightened to the specification.

- 1 : Slack guide
- 3 : Cylinder block

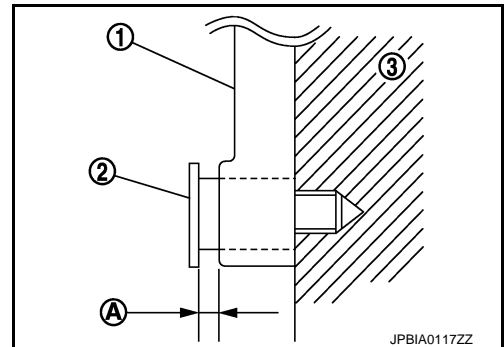

JPBIA0117ZZ

5. Install timing chain tensioner as per the following:

TIMING CHAIN

[VK50VE]

< UNIT DISASSEMBLY AND ASSEMBLY >

- a. Fix the plunger at the most compressed position using a stopper pin (A).
 - Remove any dirt and foreign materials completely from the back and the mounting surfaces of timing chain tensioner.
- b. Pull out stopper pin after installing, and then release plunger.

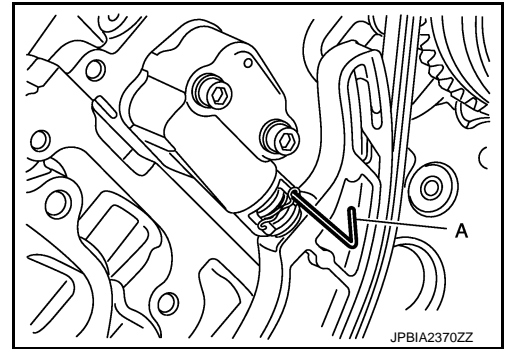

6. Check again that the matching marks on sprockets and timing chain have not slipped out of alignment.
7. Install oil pump drive chain as per the following:
 - a. Install oil pump drive chain tensioner.
 - Fix the tensioner at the most compressed position using a stopper pin. and then install it.
 - b. Install the oil pump sprocket (crankshaft side), oil pump sprocket (oil pump side) and oil pump drive chain at the same time.
 - Install each oil pump sprocket so that its flange side (the larger diameter side without teeth) (A) faces in the direction shown in the figure.

- 1 : Oil pump sprocket (crankshaft side)
- 2 : Oil pump sprocket (oil pump side)
- 3 : Oil pump
- 4 : Crankshaft

NOTE:

There is no matching mark in the oil pump related parts.

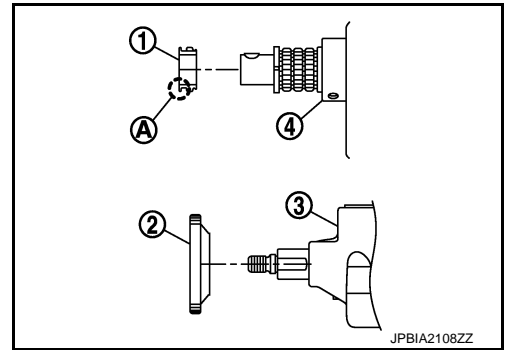

- c. Hold the two flat parts of oil pump shaft, and then tighten the oil pump sprocket (oil pump side) nut.

- 1 : Oil pump sprocket (oil pump side)

CAUTION:

Secure the oil pump shaft with the two flat parts.

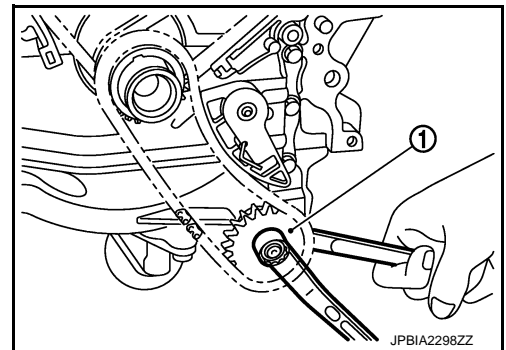

- d. Securely pull out the stopper pin (A) after installing the oil pump drive chain.
 - Check that the tension is applied to the oil pump drive chain (1) after installing.

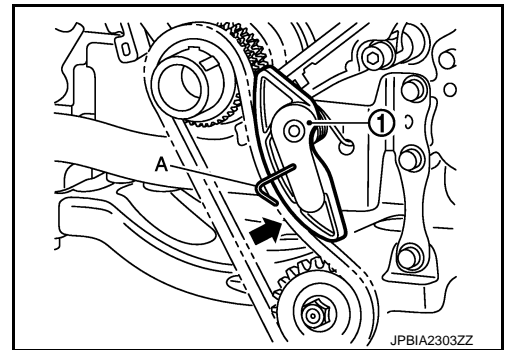

8. Install front oil seal on front cover. Refer to [.EM-194. "FRONT OIL SEAL : Removal and Installation".](#)

TIMING CHAIN

< UNIT DISASSEMBLY AND ASSEMBLY >

[VK50VE]

9. Install timing chain tensioner cover (2) to front cover (1).

a : $\phi 3.4 - 4.4$ mm (0.134 - 0.173 in)

- Apply a continuous bead of liquid gasket with tube presser (commercial service tool) to front cover as shown in the figure. **Use Genuine RTV Silicone Sealant or an equivalent. Refer to [GI-15, "Recommended Chemical Products and Sealants"](#).**

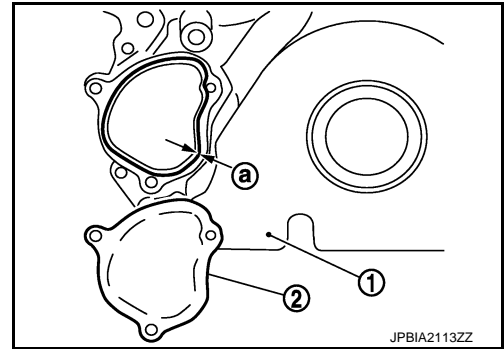

10. Install oil filter (for valve timing control solenoid valve) (1) in the direction shown in the figure, if removed.

- Check that the oil filter does not protrude from the upper surface of front cover (2) after installation.

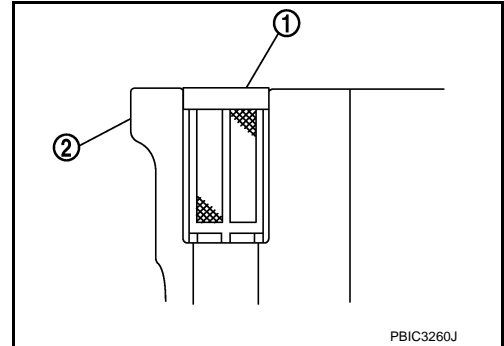

11. Install front cover as per the following:

a. Install new O-ring (1), (2) onto cylinder heads and cylinder block.

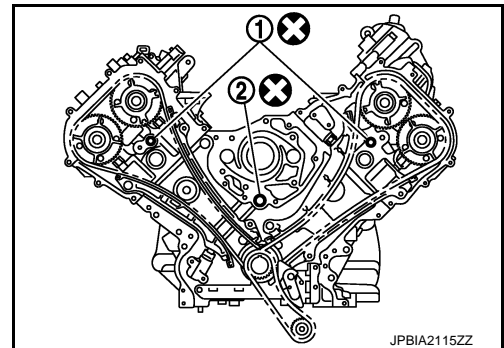

TIMING CHAIN

[VK50VE]

< UNIT DISASSEMBLY AND ASSEMBLY >

- b. Apply a continuous bead of liquid gasket with tube presser (commercial service tool) to front cover as shown in the figure. **Use Genuine RTV Silicone Sealant or equivalent. Refer to GI-15. "Recommended Chemical Products and Sealants".**

- A : Junction between cylinder block and cylinder head
- B : Protrusion
- c : 4.3 - 5.3 mm (0.169 - 0.209 in)
- d : $\phi 3.4 - 4.4$ mm (0.134 - 0.173 in)
- e : $\phi 4.0 - 5.6$ mm (0.157 - 0.220 in)
- f : $\phi 4.8 - 5.8$ mm (0.189 - 0.228 in)

- c. Check again that the matching marks on timing chain and that on each sprocket are aligned. Then, install front cover.

CAUTION:

Be careful not to damage front oil seal by interference with front end of crankshaft.

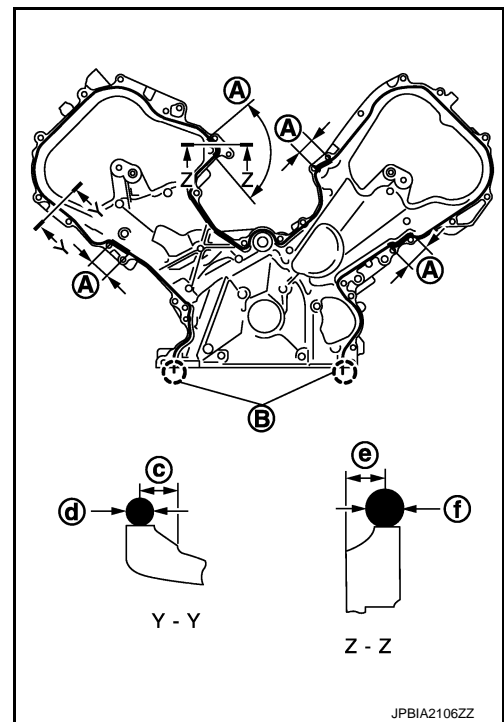

- d. Tighten mounting bolts in numerical order as shown in the figure.

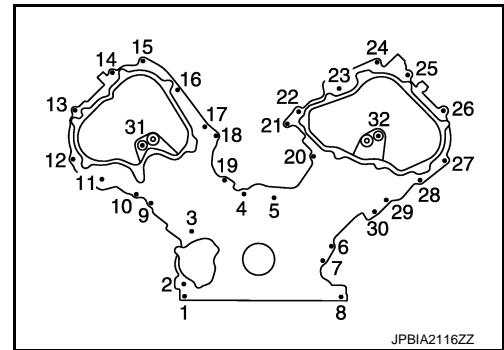

- There are three types of mounting bolts.

- A : 20 mm (0.79 in)**
- B : 45 mm (1.77 in)**
- C : 80 mm (3.15 in)**

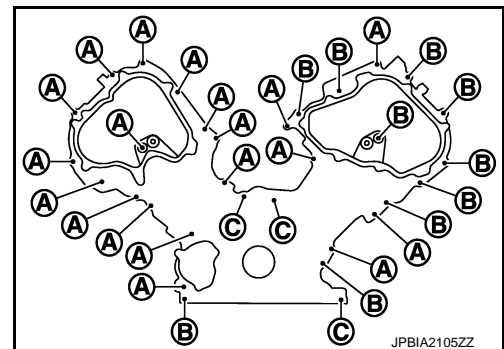

- e. After all mounting bolts are tightened, retighten them in numerical order as shown in the figure.

CAUTION:

Be sure to wipe out any excessive liquid gasket leaking onto surface mating with oil pan.

12. Install valve timing control cover as per the following:

TIMING CHAIN

[VK50VE]

< UNIT DISASSEMBLY AND ASSEMBLY >

a. Install new O-rings (1) on front cover.

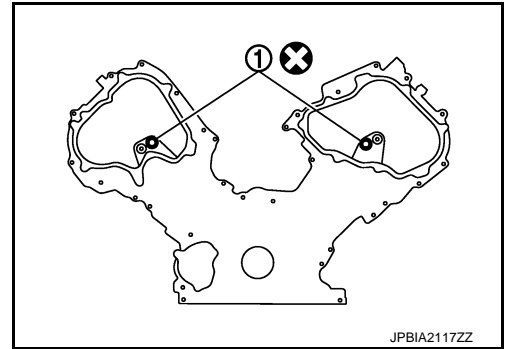

b. Install new seal rings (1) in shaft grooves.

CAUTION:
When replacing seal ring, replace all rings with new ones.

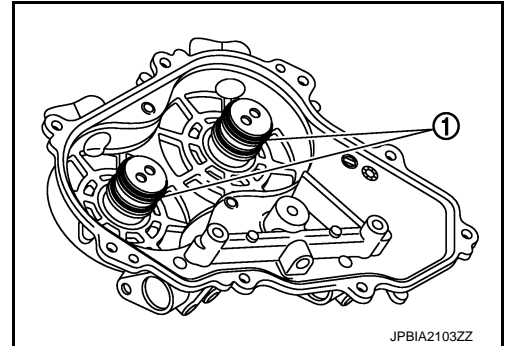

c. Apply a continuous bead of liquid gasket with tube presser (commercial service tool) to valve timing control covers as shown in the figure.

A : Bank 1

B : Bank 2

c : $\phi 3.4 - 4.4$ mm (0.134 - 0.173 in)

Use Genuine RTV Silicone Sealant or equivalent. Refer to [GI-15, "Recommended Chemical Products and Sealants"](#).

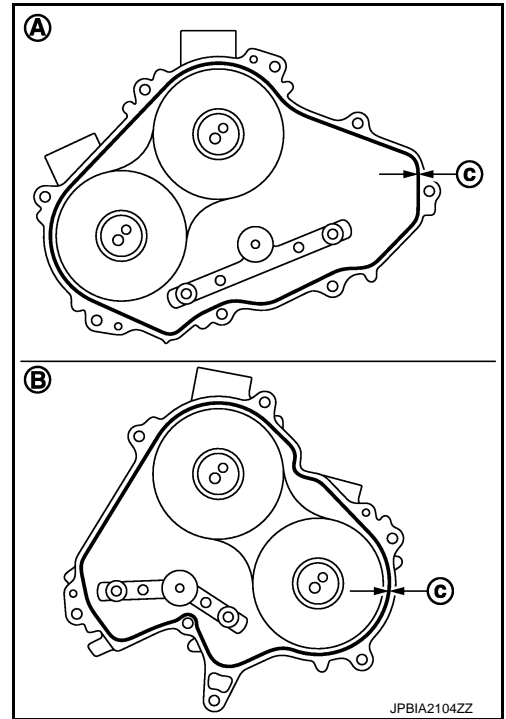

d. Being careful not to move seal ring from the installation groove, align dowel pins on front cover with dowel pin holes (C) to install valve timing control covers.

A : Bank 2

B : Bank 1

e. Tighten mounting bolts in numerical order as shown in the figure.

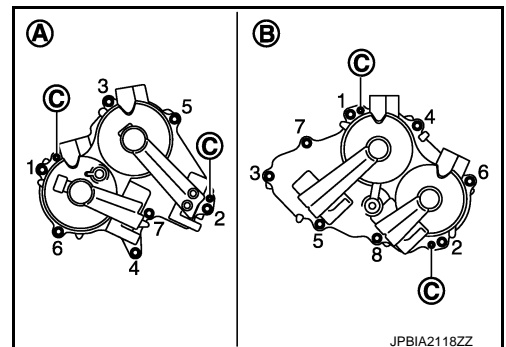

TIMING CHAIN

[VK50VE]

< UNIT DISASSEMBLY AND ASSEMBLY >

13. Install camshaft position sensor and valve timing control solenoid valve (RH and LH) to valve timing control cover, if removed.
 - Be sure to tighten mounting bolts with flanges completely seated.
 14. Install oil pan (lower) and oil strainer. Refer to [EM-188, "Exploded View"](#).
 15. Install oil pan (upper). Refer to [EM-208, "Exploded View"](#).
 16. Install water pump pulley. Refer to [CO-44, "Exploded View"](#).
 17. Install crankshaft pulley.
 - Fix the crankshaft as instructed in the removal procedure. Refer to [EM-194, "FRONT OIL SEAL : Removal and Installation"](#).
 - a. Install crankshaft pulley, taking care not to damage front oil seal.
 - b. Apply engine oil onto threaded parts of crankshaft pulley bolt and seating area.
 - Lightly tapping its center with plastic hammer, insert crankshaft pulley.
- CAUTION:**
Never tap crankshaft pulley on the side surface where belt is installed (outer circumference).
- c. Tighten crankshaft pulley bolt.

 : 157 N·m (16 kg·m, 116 ft·lb)

- d. Put a paint mark (A) on crankshaft pulley (1) aligning with angle mark (B) on crankshaft pulley bolt.
- e. Tighten crankshaft pulley bolt (clockwise).

Angle tightening: 90 degrees (c)

- Check the tightening angle by referencing to the notches. The angle between two notches is 90 degrees.

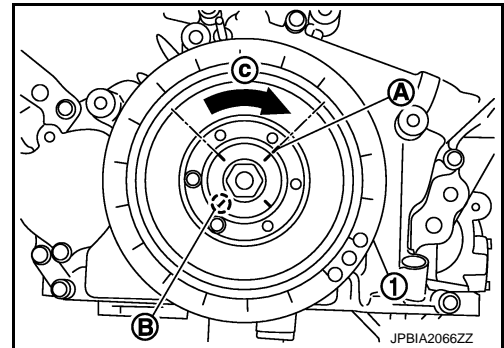

18. Rotate crankshaft pulley in normal direction (clockwise when viewed from engine front) to confirm it turns smoothly.
19. Install in the reverse order of removal.

Inspection

INFOID:000000003733436

INSPECTION AFTER DISASSEMBLY

Timing Chain

Check for cracks and any excessive wear at link plates and roller links of timing chain. Replace timing chain if necessary.

- A : Crack
B : Wear

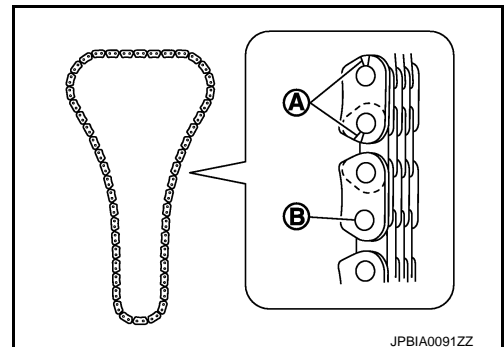

INSPECTION AFTER ASSEMBLY

Inspection for Leakage

The following are procedures for checking fluid leakage, lubricant leakage.

- Before starting engine, check oil/fluid levels including engine coolant and engine oil. If any are less than the required quantity, fill them to the specified level. Refer to [MA-12, "Fluids and Lubricants"](#).
- Follow the procedure below to check for fuel leakage.

TIMING CHAIN

< UNIT DISASSEMBLY AND ASSEMBLY >

[VK50VE]

- Turn ignition switch to the "ON" position (with engine stopped). With fuel pressure applied to fuel piping, check for fuel leakage at connection points.
- Start engine. With engine speed increased, check again for fuel leakage at connection points.
- Run engine to check for unusual noise and vibration.

NOTE:

If hydraulic pressure inside chain tensioner drops after removal/installation, slack in guide may generate a pounding noise during and just after the engine start. However, this does not indicate a malfunction. The noise will stop after hydraulic pressure rises.

- Warm up engine thoroughly to check that there is no leakage of fuel, or any oil/fluids including engine oil and engine coolant.
- Bleed air from lines and hoses of applicable lines, such as in cooling system.
- After cooling down engine, again check oil/fluid levels including engine oil and engine coolant. Refill them to the specified level, if necessary.

Summary of the inspection items:

Items	Before starting engine	Engine running	After engine stopped
Engine coolant	Level	Leakage	Level
Engine oil	Level	Leakage	Level
Other oils and fluids*	Level	Leakage	Level
Fuel	Leakage	Leakage	Leakage

* Transmission/transaxle/CVT fluid, power steering fluid, brake fluid, etc.

CAMSHAFT

< UNIT DISASSEMBLY AND ASSEMBLY >

[VK50VE]

CAMSHAFT

Exploded View

INFOID:000000003733450

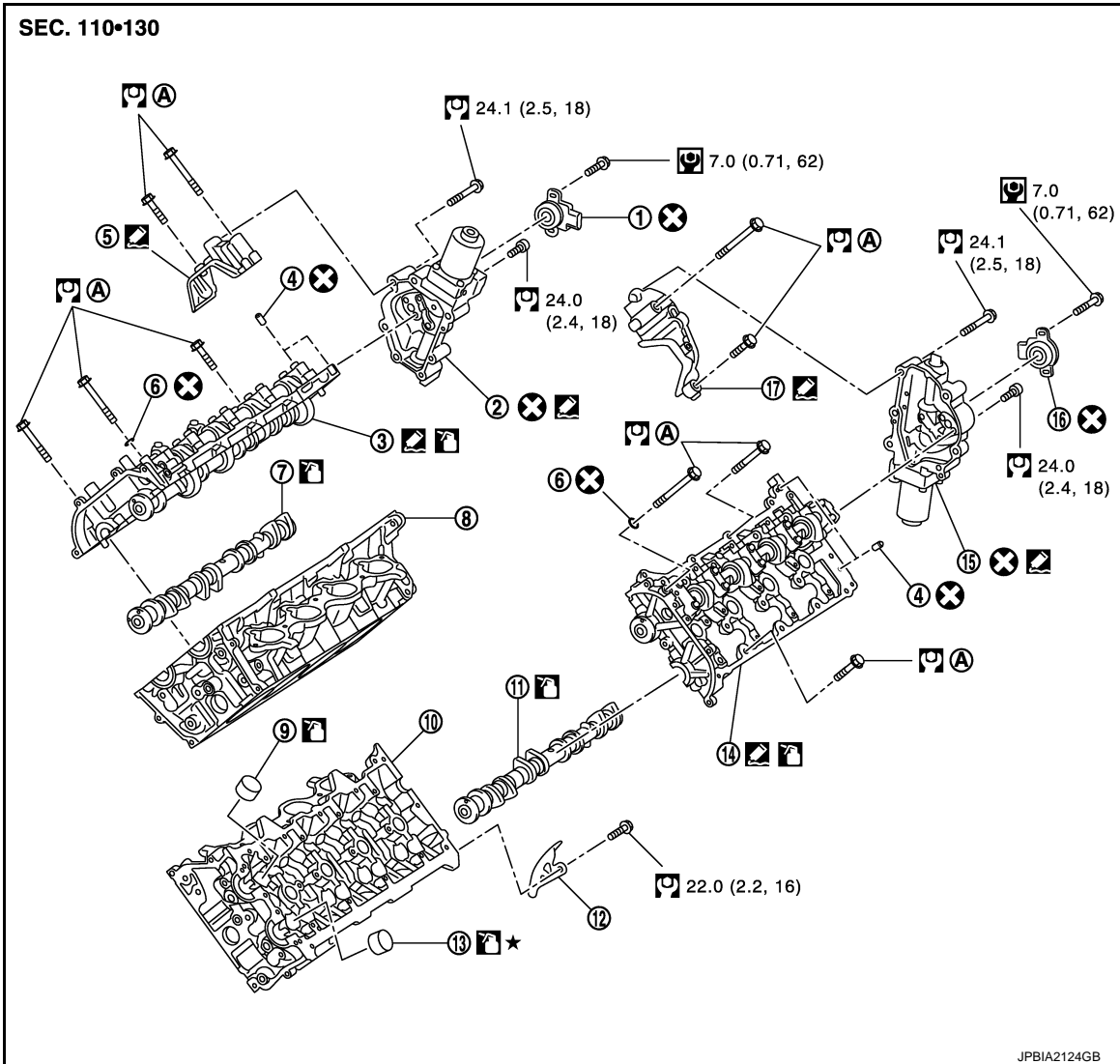

- | | | |
|---|--|---|
| 1. VVEL control shaft position sensor (bank 2) | 2. VVEL actuator sub assembly (bank 2) | 3. VVEL ladder assembly (bank 2) |
| 4. Dowel pin | 5. Actuator bracket (rear) (bank 2) | 6. Washer |
| 7. Camshaft (EXH) (bank 2) | 8. Cylinder head (bank 2) | 9. Valve lifter (INT) |
| 10. Cylinder head (bank 1) | 11. Camshaft (EXH) (bank 1) | 12. Actuator cover |
| 13. Valve lifter (EXH) | 14. VVEL ladder assembly (bank 1) | 15. VVEL actuator sub assembly (bank 1) |
| 16. VVEL control shaft position sensor (bank 1) | 17. Actuator bracket (rear) (bank 1) | |

A. Refer to [EM-228](#)

Refer to [GI-4, "Components"](#) for symbol marks in the figure.

CAUTION:

A high degree of precision is required for a valve on the intake side. Never remove the valve related parts unless necessary.

NOTE:

- As for replacement of parts on the intake side as shown in the exploded view, replace VVEL ladder assembly & cylinder head assembly.

CAMSHAFT

< UNIT DISASSEMBLY AND ASSEMBLY >

[VK50VE]

- VVEL ladder assembly cannot be replaced as a single part, because it is machined together with cylinder head assembly.

VVEL Ladder Assembly & Cylinder Head Assembly Features

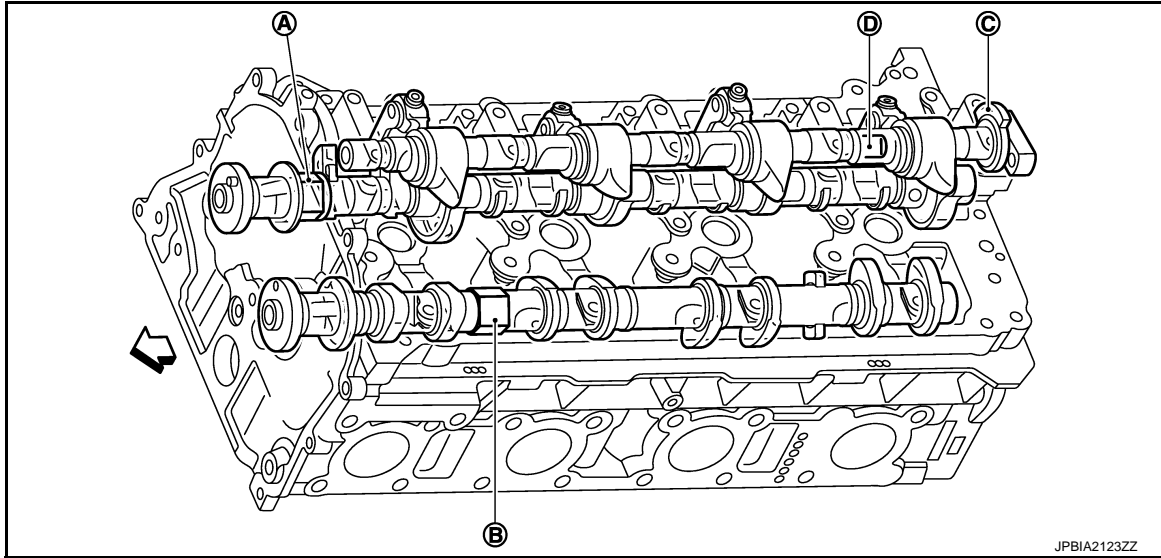

- A. Hexagonal part of drive shaft (for holding) B. Hexagonal part of camshaft (EXH) (for holding) C. Stopper of control shaft
D. Two flat areas of control shaft (for holding)
↶ : Engine front

NOTE:

The figure shows an example of bank 1.

Disassembly and Assembly

INFOID:000000003733451

DISASSEMBLY

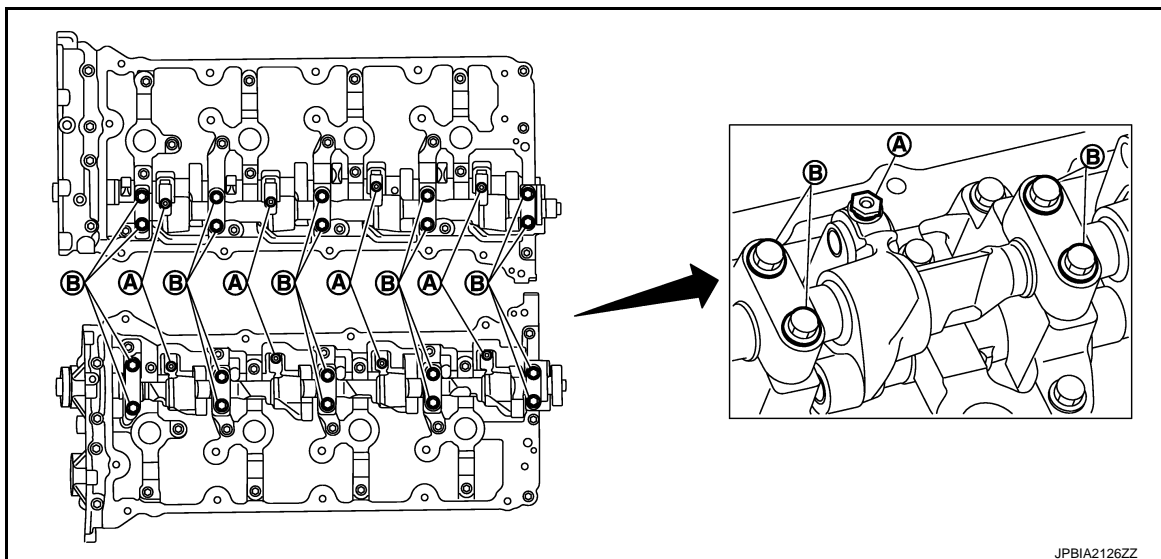

CAUTION:

Never loosen adjusting bolts (A) and mounting bolts (black color) (B) of VVEL ladder assembly. If loosened, the stroke of cam lift becomes out of adjustment. In such case, replacement of VVEL ladder assembly and cylinder head assembly is required.

NOTE:

VVEL ladder assembly cannot be replaced as a single part, because it is machined together with cylinder head assembly.

1. Remove rocker covers (bank 1 and bank 2). Refer to [EM-191, "Exploded View"](#).

CAMSHAFT

< UNIT DISASSEMBLY AND ASSEMBLY >

[VK50VE]

2. Remove VVEL actuator sub assembly as per the following:

CAUTION:

VVEL actuator sub assembly and VVEL control shaft position sensor are not reusable. Never remove them unless they are required.

- a. Remove VVEL control shaft position sensor.
b. Fix two flat areas (C) of control shaft with a wrench to remove mounting bolts of control shaft.

- A : Bank 2
B : Bank 1
⇐ : Engine front

CAUTION:

- During the operation, never allow a wrench to interfere with other parts.
- Fix control shaft to prevent the interference of the stopper surface.

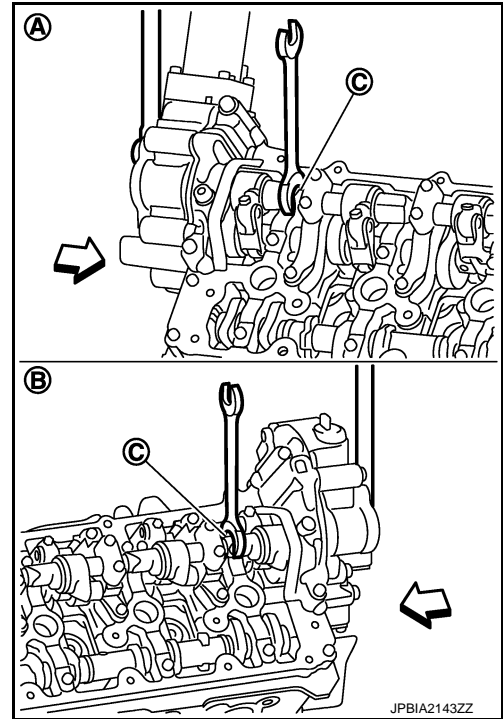

- c. Remove VVEL actuator sub assembly.
• Loosen mounting bolts in the reverse order as shown in the figure.

- A : Bank 1
B : Bank 2

CAUTION:

- When removing, prepare wastes because oil spills.
- When installing, be careful with VVEL actuator sub assembly (bank 1) mounting bolt No. 4 because its length is different.

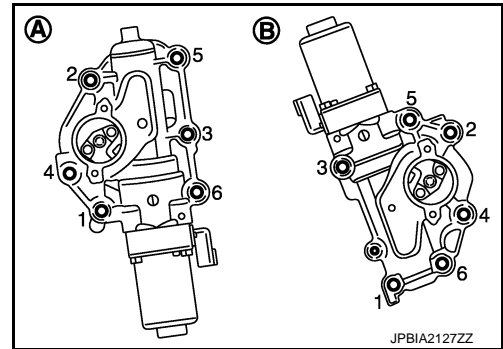

- d. Remove actuator bracket (rear).
• Loosen mounting bolts in the reverse order as shown in the figure.

- A : Bank 2
B : Bank 1
⇐ : Engine front

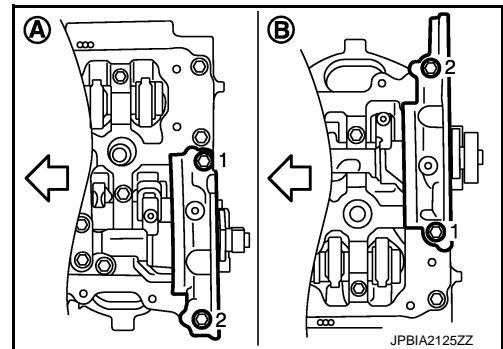

3. Remove front cover, camshaft sprockets, and timing chains. Refer to [EM-212, "Exploded View"](#).
4. Remove VVEL ladder assembly.

A
EM
C
D
E
F
G
H
I
J
K
L
M
N
O
P

CAMSHAFT

[VK50VE]

< UNIT DISASSEMBLY AND ASSEMBLY >

- Loosen mounting bolts (gold color) in the reverse order as shown in the figure.

A : Bank 2

B : Bank 1

← : Engine front

CAUTION:

- Never loosen adjusting bolts and mounting bolts (black color).
- When removing VVEL ladder assembly, hold the drive shaft from below so as not to drop it.

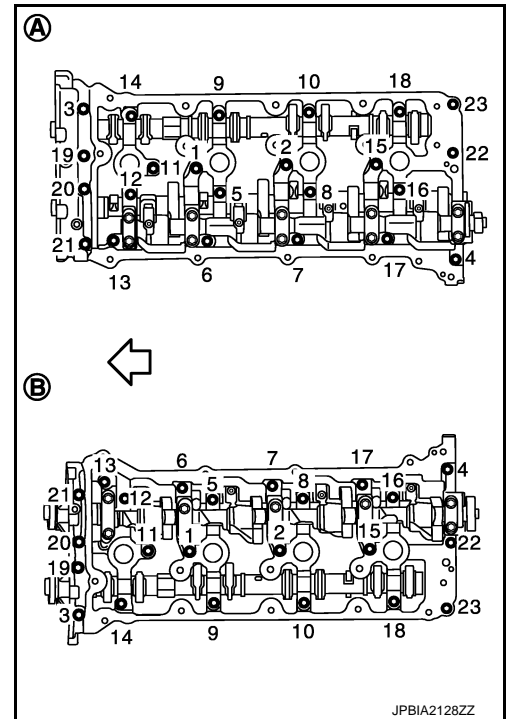

- Remove camshaft (EXH).
- Remove valve lifter, if necessary.
 - Identify installation positions, and store them without mixing them up.

ASSEMBLY

- Install valve lifter.
 - Install it in the original position.
- Install camshaft (EXH).
 - Distinction between camshaft (EXH) is performed with the identification mark.

← : Engine front

Bank	Paint marks		Identification rib (E)
	M1 (C)	M2 (D)	
Bank 2 (A)	No	Green	Yes
Bank 1 (B)	No	Green	No

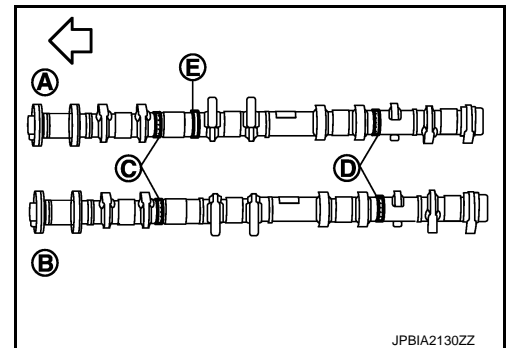

- Install VVEL ladder assembly as per the following:

CAMSHAFT

[VK50VE]

< UNIT DISASSEMBLY AND ASSEMBLY >

- a. Apply a continuous bead of liquid gasket with tube presser (commercial service tool) to the cylinder head as shown in the figure.

- A : Bank 1
- B : Bank 2
- c : $\phi 3.4 - 4.4$ mm (0.134 - 0.173 in)
-  : Engine front

Use Genuine RTV Silicone Sealant or an equivalent. Refer to [GI-15, "Recommended Chemical Products and Sealants"](#).

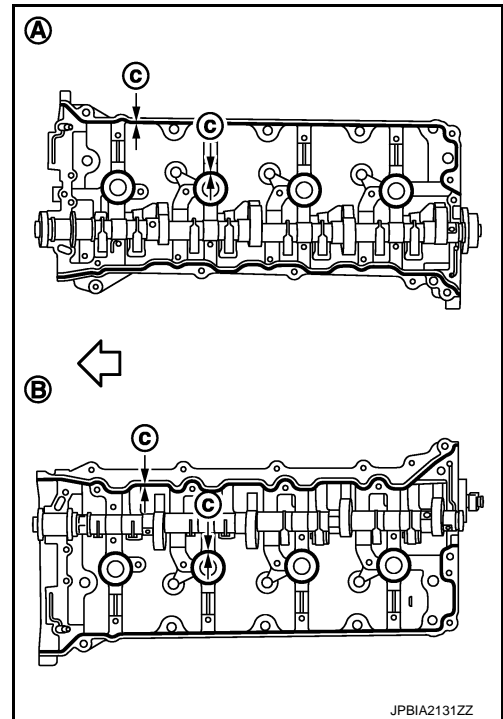

- b. Tighten mounting bolts in the following step, in numerical order as shown.

- A : Bank 2
- B : Bank 1
-  : Engine front

- i. Tighten bolts in numerical order as shown.

 : **1.96 N·m (0.20 kg-m, 1 ft-lb)**

- ii. Tighten bolts in numerical order as shown.

 : **5.88 N·m (0.60 kg-m, 4 ft-lb)**

- iii. Tighten bolts in numerical order as shown.

 : **10.4 N·m (1.1 kg-m, 8 ft-lb)**

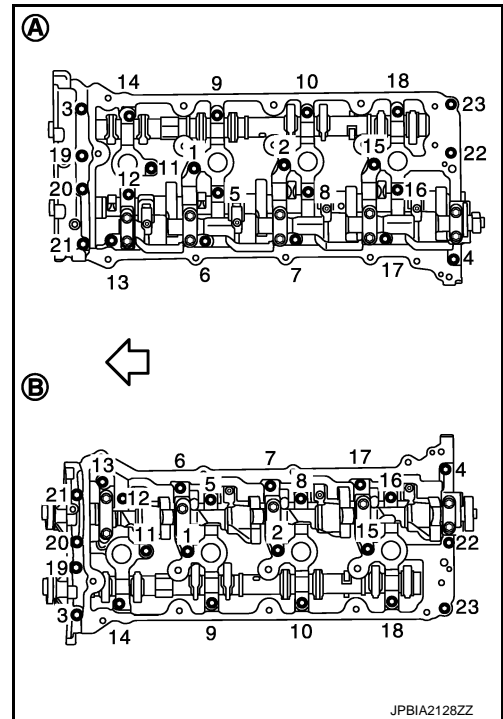

4. Install camshaft sprockets and timing chains. Refer to [EM-212, "Exploded View"](#).

5. Install actuator bracket (rear) as per the following:

CAMSHAFT

< UNIT DISASSEMBLY AND ASSEMBLY >

[VK50VE]

- a. Refer to the figure to replace new dowel pins (2), if removed.

- 1 : Actuator bracket
- 3 : VVEL ladder assembly
- a : 4.0 - 6.0 mm (0.157 - 0.236 in)

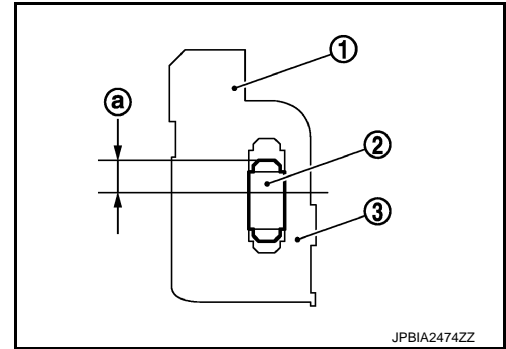

- b. Apply a continuous bead of liquid gasket with tube presser (commercial service tool) to the actuator bracket (rear) as shown in the figure.

- A : Bank 2
- B : Bank 1
- c : $\phi 3.4 - 4.4$ mm (0.134 - 0.173 in)
- ⇐ : Engine front

Use Genuine RTV Silicone Sealant or an equivalent. Refer to [GI-15. "Recommended Chemical Products and Sealants"](#).

CAUTION:

Never apply gasket to the oil passage.

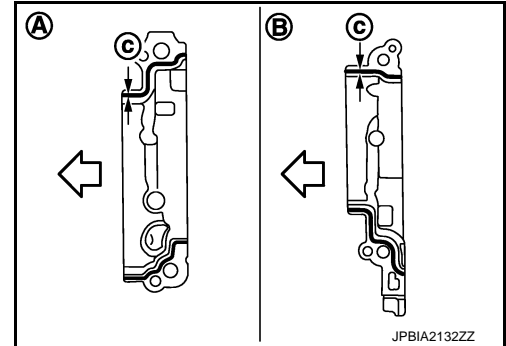

- c. Tighten mounting bolts in the following steps, in numerical order as shown.

- A : Bank 2
- B : Bank 1
- ⇐ : Engine front

- i. Tighten bolts in numerical order as shown.

 : 1.96 N·m (0.20 kg-m, 1 ft-lb)

- ii. Tighten bolts in numerical order as shown.

 : 5.88 N·m (0.60 kg-m, 4 ft-lb)

- iii. Tighten bolts in numerical order as shown.

 : 31.4 N·m (3.2 kg-m, 23 ft-lb)

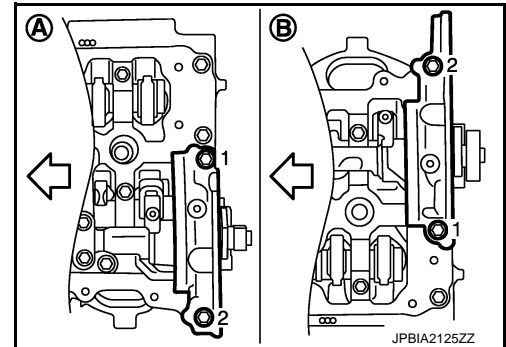

6. Install new VVEL actuator sub assembly as per the following:

CAUTION:

Regarding replacement, because VVEL actuator sub assembly and VVEL control shaft position sensor are controlled on a one-on-one basis, replace them as a set.

NOTE:

CAMSHAFT

< UNIT DISASSEMBLY AND ASSEMBLY >

[VK50VE]

- VVEL actuator arm (B) is factory-fixed at 10 degrees from the small lift with a holding jig (A).
- The holding jig is supplied in the new VVEL actuator sub assembly.

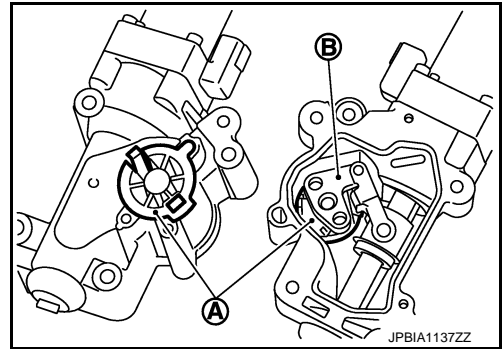

CAUTION:

- Never disassemble VVEL actuator sub assembly. [Never loosen actuator motor mounting bolts (A) shown in the figure]
- Never impact VVEL actuator sub assembly.

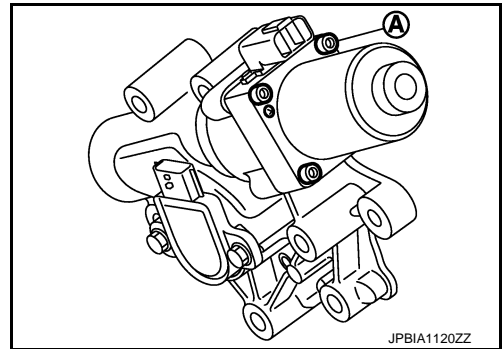

- a. Move control shaft to the position of small lift stopper.
- The position where a part of the stopper of control shaft contacts VVEL ladder bracket.

- 1 : VVEL ladder assembly (bank 2)
- 2 : VVEL ladder assembly (bank 1)
- A : Stopper of control shaft
- ← : Small lift side

CAUTION:

Be careful not to damage the stopper surface.

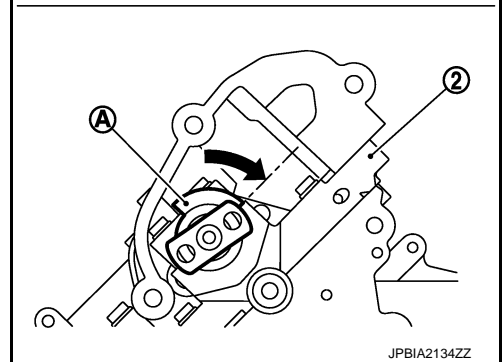
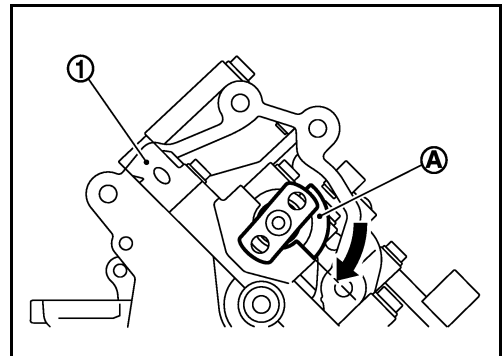

- If control shaft cannot be moved, set crankshaft in position referring to the information below. (To displace cam nose)

Bank 1 : Turn 360 degrees from No. 1 cylinder at TDC

Bank 2 : No. 1 cylinder at TDC

CAMSHAFT

< UNIT DISASSEMBLY AND ASSEMBLY >

[VK50VE]

- b. Hold two flat areas of control shaft with a wrench, and rotate the control shaft (10 degrees from the stopper) to the large lift side. (This is for aligning the bolt hole of control shaft and the hole of VVEL actuator arm.)

- 1 : VVEL actuator sub assembly (bank 2)
- A : Control shaft
- B : View B
- C : Holding jig
- d : 10 degrees
- ← : Large lift side

NOTE:

The figure shows an example of bank 2.

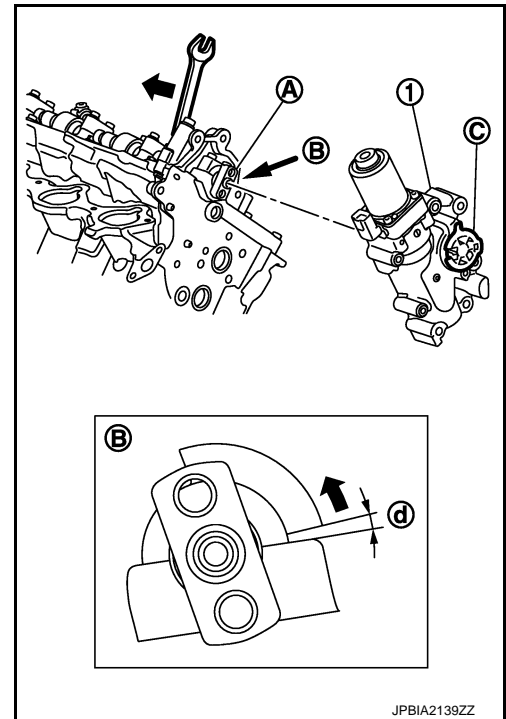

- c. Apply a continuous bead of liquid gasket with tube presser (commercial service tool) to the VVEL actuator sub assembly as shown in the figure.

- 1 : VVEL actuator sub assembly (bank 2)
- 2 : VVEL actuator sub assembly (bank 1)
- a : 4.0 - 5.6 mm (0.157 - 0.220 in)
- b : ϕ 3.4 - 4.4 mm (0.134 - 0.173 in)

Use Genuine RTV Silicone Sealant or an equivalent. Refer to [GI-15, "Recommended Chemical Products and Sealants"](#).

CAUTION:

Never apply gasket to the oil passage.

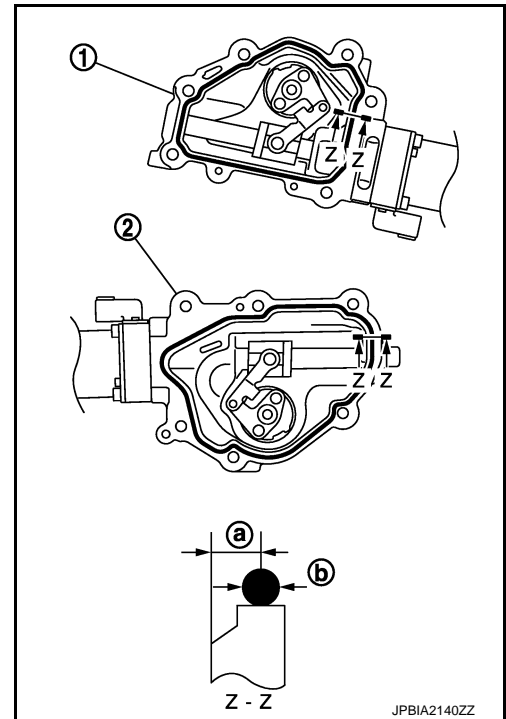

- d. Install new VVEL actuator sub assembly.
- Tighten mounting bolts in the following step, in numerical order as shown.

- A : Bank 1
- B : Bank 2

CAUTION:

- When installing, be careful with VVEL actuator sub assembly (bank 1) mounting bolt No. 4 because its length is different.

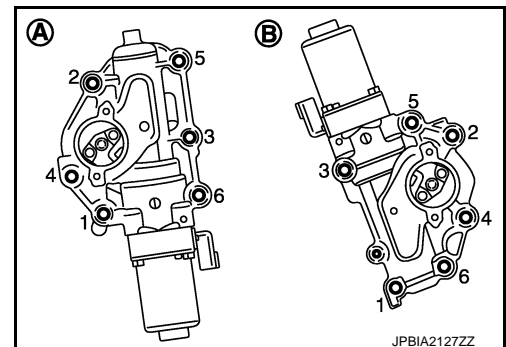

CAMSHAFT

< UNIT DISASSEMBLY AND ASSEMBLY >

[VK50VE]

- Be sure to check that the VVEL actuator sub assembly is in contact with the cylinder head before tightening the mounting bolts.

- e. Remove holding jig.
- f. Check that VVEL actuator arm bolt hole is aligned with control shaft tapped hole. If it is not aligned, turn control shaft for alignment.

CAUTION:

Never give an impact to the magnet part. (A)

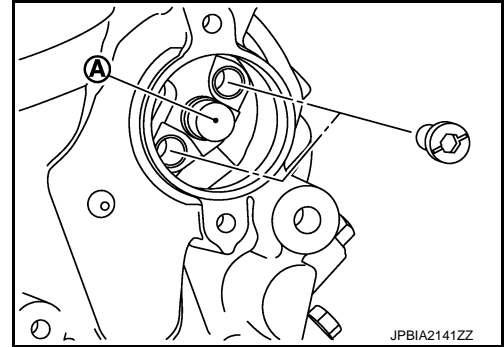

- g. Fix two flat areas (C) of control shaft with a wrench to tighten mounting bolts of control shaft.

A : Bank 2

B : Bank 1

⇐ : Engine front

CAUTION:

- During the operation, never allow a wrench to interfere with other parts.
- Fix control shaft to prevent the interference of the stopper surface.

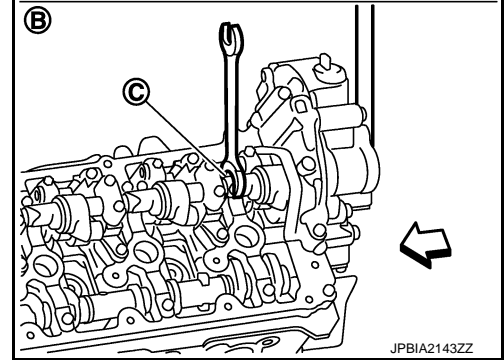
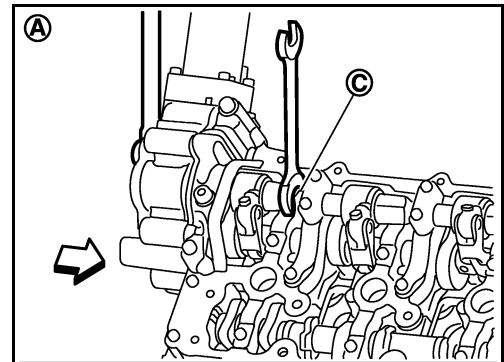

7. Install new VVEL control shaft position sensor as per the following:

CAUTION:

Regarding replacement, because VVEL actuator sub assembly and VVEL control shaft position sensor are controlled on a one-on-one basis, replace them as a set.

- a. Apply engine oil to O-ring or contact surface of O-ring.

A
EM
C
D
E
F
G
H
I
J
K
L
M
N
O
P

CAMSHAFT

[VK50VE]

< UNIT DISASSEMBLY AND ASSEMBLY >

- b. Align matching marks (B) of VVEL control shaft position sensor and upper housing.
- Face connector toward matching mark (A).

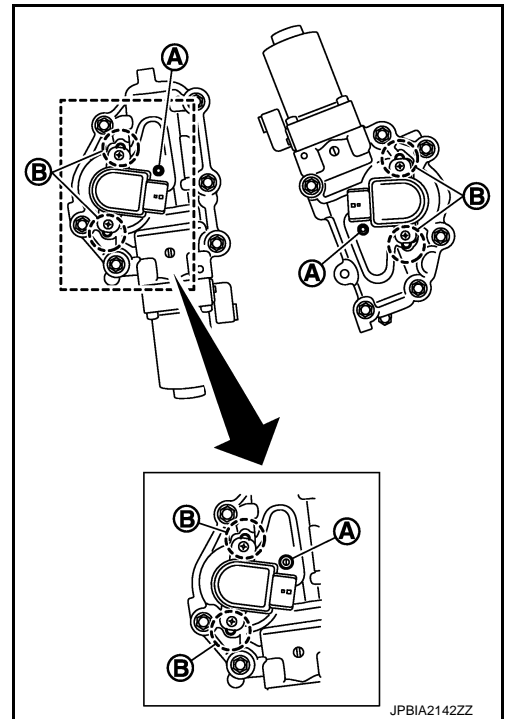

- c. Temporarily tighten bolt.
- d. Adjust VVEL control shaft position sensor after setting the engine assembly in the vehicle. Refer to [EC-584, "VVEL CONTROL SHAFT POSITION SENSOR ADJUSTMENT : Description"](#).
- CAUTION:**
Be sure to adjust VVEL control shaft position sensor.
- e. After adjusting VVEL control shaft position sensor, tighten bolts to the specified torque.
8. Install actuator cover.
9. Inspect the valve clearance. Refer to [EM-169, "Inspection"](#).
10. Install in the reverse order of removal.

Inspection

INFOID:000000003733452

CAMSHAFT (EXH) VALVE CLEARANCE ADJUSTMENT

- Perform adjustment depending on selected head thickness of valve lifter (EXH).
1. Measure the valve clearance. Refer to [EM-169, "Inspection"](#).
 2. Remove VVEL ladder assembly and camshaft (EXH). Refer to [EM-228, "Disassembly and Assembly"](#).
- CAUTION:**
Never loosen adjusting bolts and mounting bolts (black color) of VVEL ladder assembly.
3. Remove valve lifter (EXH) at the locations that are out of the standard.
 4. Measure the center thickness of the removed valve lifters (EXH) with a micrometer (A).

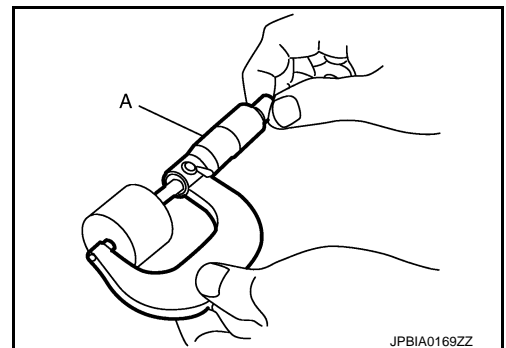

5. Use the equation below to calculate valve lifter (EXH) thickness for replacement.

CAMSHAFT

< UNIT DISASSEMBLY AND ASSEMBLY >

[VK50VE]

Valve lifter (EXH) thickness calculation: $t = t_1 + (C_1 - C_2)$

t = Valve lifter (EXH) thickness to be replaced

t₁ = Removed valve lifter (EXH) thickness

C₁ = Measured valve clearance

C₂ = Standard valve clearance:

Exhaust : 0.33 mm (0.013 in)

- Thickness of new valve lifter (EXH) can be identified by stamp marks on the reverse side (inside the cylinder). Stamp mark 788 indicates 7.88 mm (0.3102 in) in thickness.

A : Stamp

B : Thickness of valve lifter (EXH)

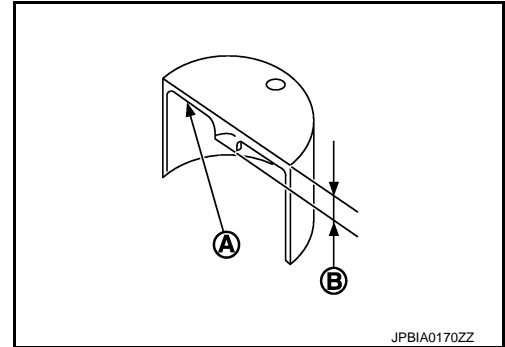

Available thickness of valve lifter (EXH): 27 sizes with range 7.88 to 8.40 mm (0.3102 to 0.3307 in) in steps of 0.02 mm (0.0008 in) (when manufactured at factory). Refer to [EM-283, "Camshaft"](#).

6. Install selected valve lifter (EXH).
7. Install VVEL ladder assembly and camshaft (EXH). Refer to [EM-228, "Disassembly and Assembly"](#).
8. Manually turn crankshaft pulley a few turns.
9. Check that the valve clearances for cold engine are within the specifications by referring to the specified values. Refer to [EM-169, "Inspection"](#).
10. Install all removed parts in the reverse order of removal.
11. Warm up the engine, and check for unusual noise and vibration.

INSPECTION AFTER DISASSEMBLY (EXHAUST SIDE)

Camshaft (EXH) Runout

1. Put V-block on precise flat table, and support No. 2 and 5 journals of camshaft.

CAUTION:

Never support No. 1 journal (on the side of camshaft sprocket) because it has a different diameter from the other four locations.

2. Set a dial indicator vertically to No. 3 journal.
3. Turn camshaft (EXH) to one direction with hands, and measure the camshaft runout on a dial indicator. (Total indicator reading)

Standard and limit

: Refer to [EM-283, "Camshaft"](#).

4. If it exceeds the limit, replace camshaft (EXH).

Camshaft (EXH) Cam Height

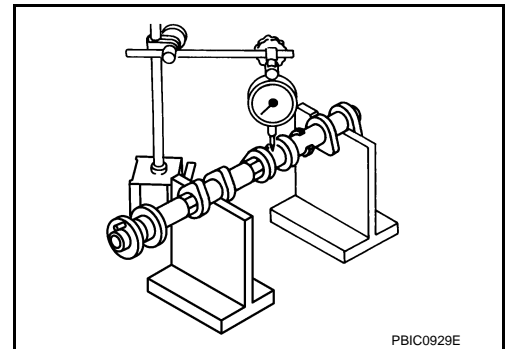

CAMSHAFT

< UNIT DISASSEMBLY AND ASSEMBLY >

[VK50VE]

- Measure the camshaft (EXH) cam height with a micrometer.

Standard and limit

: Refer to [EM-283, "Camshaft"](#).

- If wear exceeds the limit, replace camshaft (EXH).

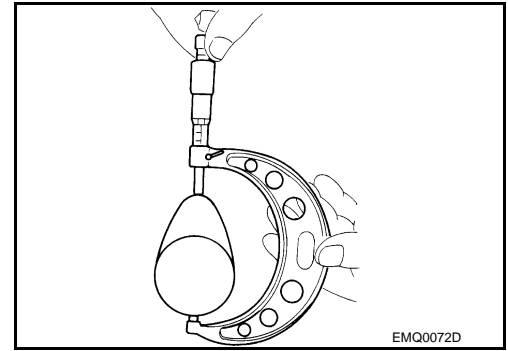

Camshaft (EXH) Journal Oil Clearance

CAMSHAFT (EXH) JOURNAL DIAMETER

- Measure the outer diameter of camshaft (EXH) journal with a micrometer (A).

Standard : Refer to [EM-283, "Camshaft"](#).

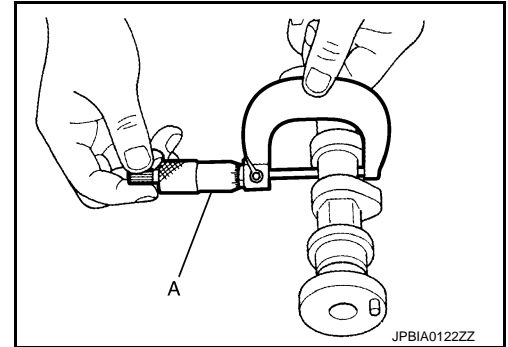

VVEL LADDER ASSEMBLY (EXH SIDE) INNER DIAMETER

- Tighten VVEL ladder assembly bolts to the specified torque. Refer to "ASSEMBLY" for the tightening procedure.
- Measure inner diameter (A) of VVEL ladder assembly (EXH side) with a bore gauge.

Standard : Refer to [EM-283, "Camshaft"](#).

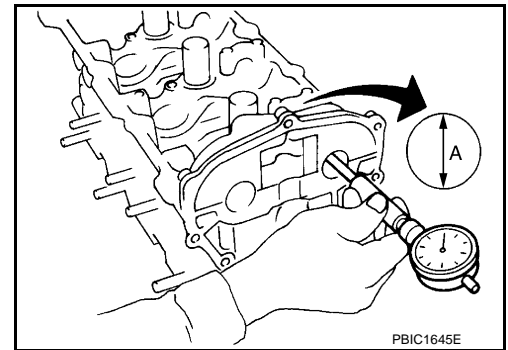

CAMSHAFT (EXH) JOURNAL OIL CLEARANCE

- (Oil clearance) = [VVEL ladder assembly (EXH side) inner diameter] – [Camshaft (EXH) journal diameter].

Standard and limit : Refer to [EM-283, "Camshaft"](#).

- If the calculated value exceeds the limit, replace either or both camshaft (EXH) and VVEL ladder assembly & cylinder head assembly.

NOTE:

VVEL ladder assembly cannot be replaced as a single part, because it is machined together with cylinder head assembly.

Camshaft (EXH) End Play

CAMSHAFT

< UNIT DISASSEMBLY AND ASSEMBLY >

[VK50VE]

- Install a dial indicator in thrust direction on front end of camshaft. Measure the end play of a dial indicator when camshaft (EXH) is moved forward/backward (in direction of axis).

Standard and limit : Refer to [EM-283, "Camshaft"](#).

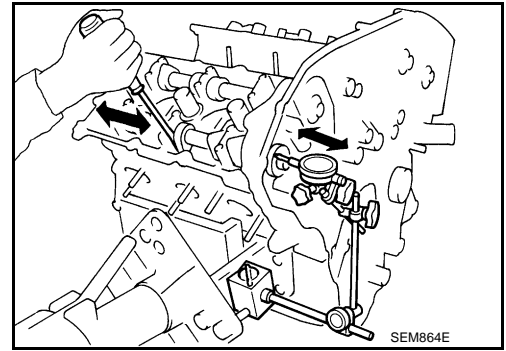

- Measure the following parts if out of the limit.
 - Dimension "A" for camshaft (EXH) No. 1 journal

Standard : 30.500 - 30.548 mm (1.2008 - 1.2027 in)

- Dimension "B" for cylinder head No. 1 journal bearing

Standard : 30.360 - 30.385 mm (1.1953 - 1.1963 in)

- Refer to the standards above, and then replace camshaft (EXH) and/or VVEL ladder assembly & cylinder head assembly.

NOTE:

Cylinder head assembly cannot be replaced as a single part, because it is machined together with VVEL ladder assembly.

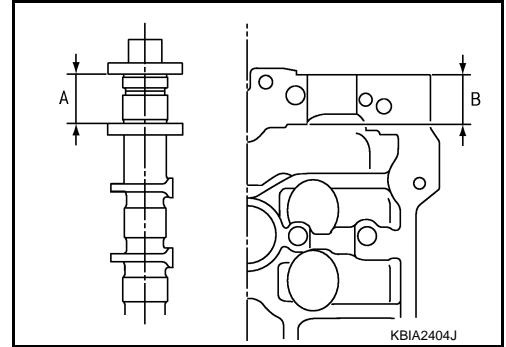

Camshaft Sprocket (EXH) Runout

1. Put V-block on precise flat table, and support No. 2 and 5 journals of camshaft (EXH).

CAUTION:

Never support No. 1 journal (on the side of camshaft sprocket) because it has a different diameter from the other four locations.

2. Measure the camshaft sprocket (EXH) runout with a dial indicator. (Total indicator reading)

Limit : Refer to [EM-283, "Camshaft"](#).

3. If it exceeds the limit, replace camshaft sprocket (EXH).

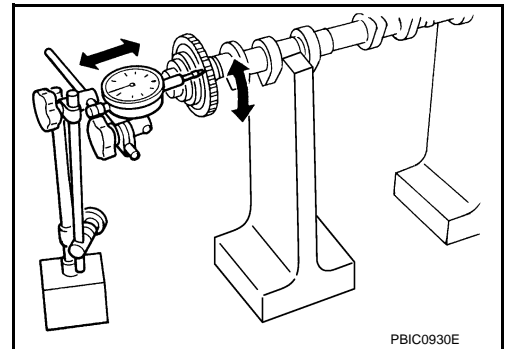

Valve Lifter (EXH)

- Check if surface of valve lifter has any wear or crack.
- If wear or crack is found, replace valve lifter (EXH). Refer to [EM-283, "Camshaft"](#).

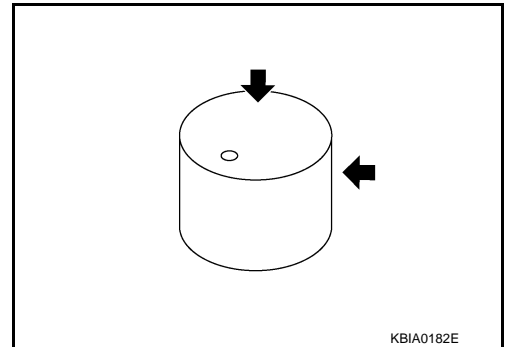

Valve Lifter Clearance (EXH)

VALVE LIFTER OUTER DIAMETER

CAMSHAFT

[VK50VE]

< UNIT DISASSEMBLY AND ASSEMBLY >

- Measure the outer diameter at 1/2 height of valve lifter with a micrometer (A) since valve lifter is in barrel shape.

Standard : Refer to [EM-283, "Camshaft"](#).

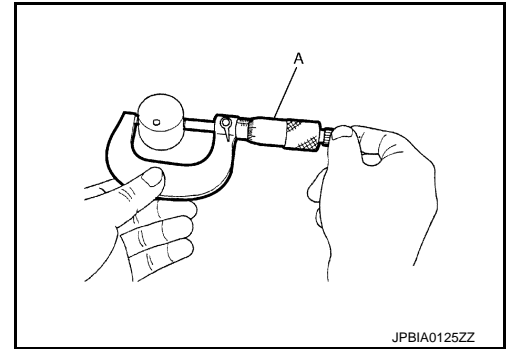

JPBIA0125ZZ

VALVE LIFTER HOLE DIAMETER

- Measure the inner diameter of valve lifter hole of cylinder head with an inside micrometer.

Standard : Refer to [EM-283, "Camshaft"](#).

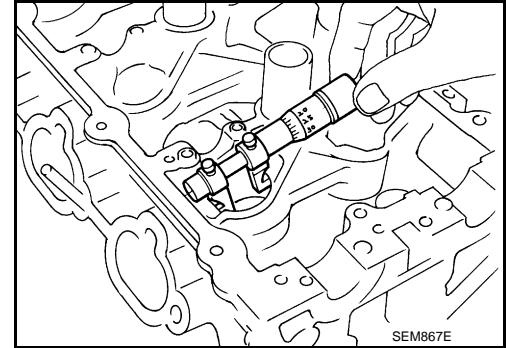

SEM867E

VALVE LIFTER CLEARANCE

- (Valve lifter clearance) = (Valve lifter hole diameter) – (Valve lifter outer diameter)

Standard : Refer to [EM-283, "Camshaft"](#).

- If the calculated value is out of the standard, referring to each standard of valve lifter outer diameter and valve lifter hole diameter, replace either or both valve lifter and VVEL ladder assembly & cylinder head assembly.

NOTE:

Cylinder head assembly cannot be replaced as a single part, because it is machined together with VVEL ladder assembly.

INSPECTION AFTER DISASSEMBLY (INTAKE SIDE)

Drive Shaft End Play

- Install a dial indicator in thrust direction on front end of drive shaft. Measure the end play of a dial indicator when drive shaft is moved forward/backward (in direction of axis).

Standard and limit : Refer to [EM-283, "Camshaft"](#).

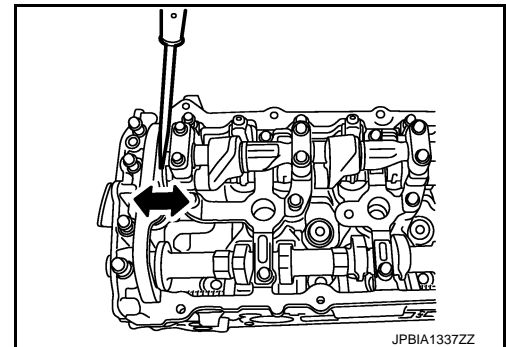

JPBIA1337ZZ

CAMSHAFT

[VK50VE]

< UNIT DISASSEMBLY AND ASSEMBLY >

- Measure the following parts if out of the limit.
- Dimension "A" for drive shaft No. 1 journal

Standard : 30.500 - 30.548 mm (1.2008 - 1.2027 in)

- Dimension "B" for cylinder head No. 1 journal bearing

Standard : 30.360 - 30.385 mm (1.1953 - 1.1963 in)

- If it exceeds the limit, replace VVEL ladder assembly & cylinder head assembly.

NOTE:

Cylinder head assembly cannot be replaced as a single part, because it is machined together with VVEL ladder assembly.

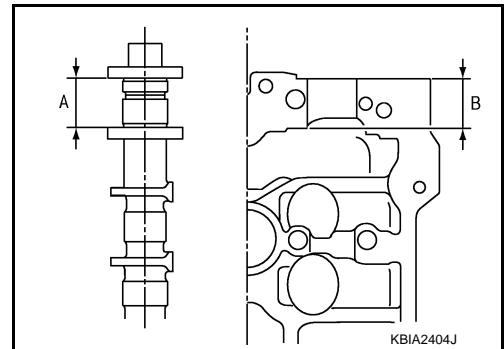

A

EM

C

D

Camshaft Sprocket (INT) Runout

1. Put V-block on precise flat table, and support No. 2 and 5 journals of drive shaft.

CAUTION:

Never support No. 1 journal (on the side of camshaft sprocket) because it has a different diameter from the other four locations.

2. Measure the camshaft sprocket (INT) runout with a dial indicator. (Total indicator reading)

Limit : Refer to EM-283, "Camshaft".

3. If it exceeds the limit, replace camshaft sprocket (INT).

Valve Lifter (INT)

- Check if surface of valve lifter has any wear or crack.
- If wear or crack is found, replace VVEL ladder assembly & cylinder head assembly. Refer to [EM-283, "Camshaft"](#).

NOTE:

Since the valve lifter (INT) cannot be replaced by the piece, VVEL ladder assembly & cylinder head assembly replacement are required.

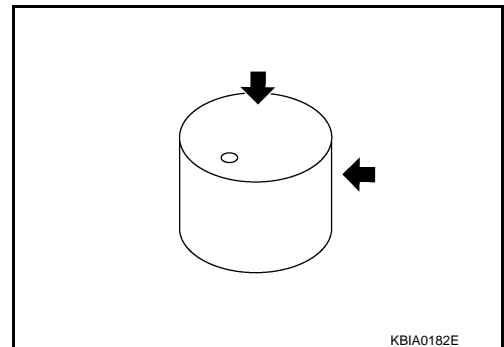

E

F

G

H

I

J

K

Valve Lifter Clearance (INT)

VALVE LIFTER OUTER DIAMETER

- Measure the outer diameter at 1/2 height of valve lifter (INT) with a micrometer (A) since valve lifter is in barrel shape.

Standard : Refer to EM-283, "Camshaft".

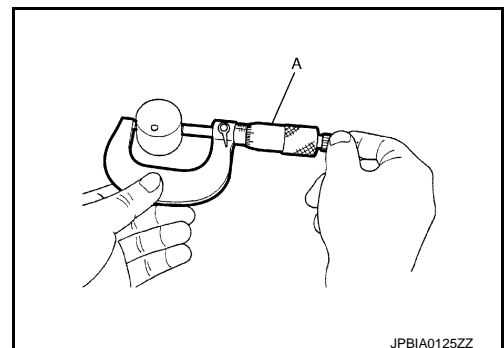

L

M

N

O

VALVE LIFTER HOLE DIAMETER

P

CAMSHAFT

< UNIT DISASSEMBLY AND ASSEMBLY >

[VK50VE]

- Measure the inner diameter of valve lifter hole of cylinder head with an inside micrometer.

Standard : Refer to [EM-283, "Camshaft"](#).

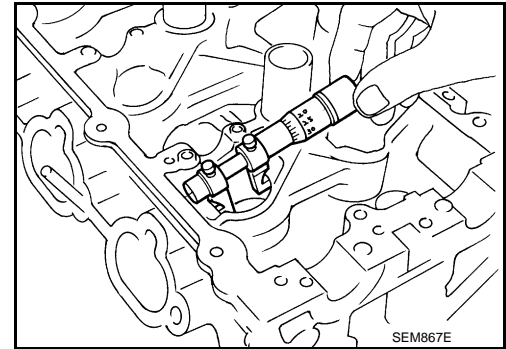

VALVE LIFTER CLEARANCE

- (Valve lifter clearance) = (Valve lifter hole diameter) – (Valve lifter outer diameter)

Standard : Refer to [EM-283, "Camshaft"](#).

- If the calculated value is out of the standard, replace VVEL ladder assembly & cylinder head assembly.

NOTE:

Since the valve lifter (INT) cannot be replaced by the piece, VVEL ladder assembly & cylinder head assembly replacement are required.

VVEL Ladder Assembly

DRIVE SHAFT OPERATIONAL CHECK

- Hold the both ends of the drive shaft (A) and rotate it to check that it rotates smoothly.

CAUTION:

Turn VVEL ladder assembly upside down to prevent the drive shaft from dropping off.

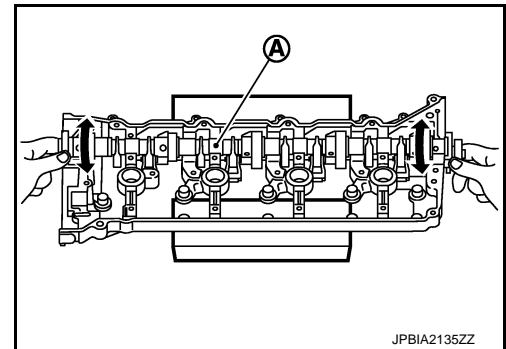

CONTROL SHAFT OPERATIONAL CHECK

- Move control shaft (A) to the small stopper and large stopper to check that the control shaft functions smoothly.

CAUTION:

Turn VVEL ladder assembly upside down to prevent the drive shaft from dropping off.

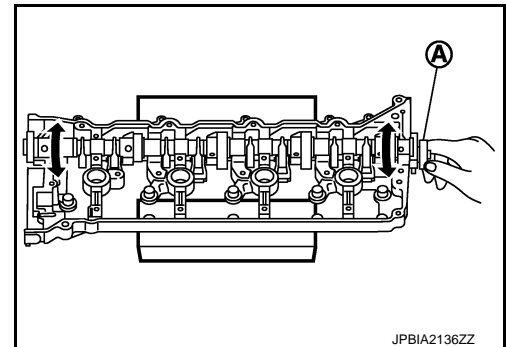

RINK CHECK FOR BACK-LASH (BONDING)

CAMSHAFT

< UNIT DISASSEMBLY AND ASSEMBLY >

[VK50VE]

- Check that the link and the shaft of drive shaft and control shaft are not fixed.
- Check this by moving drive shaft and control shaft in the axial and rotation directions.

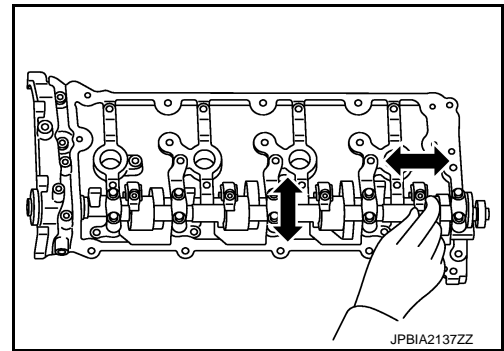

- If there is an unusualness related to the above three items, replace VVEL ladder assembly & cylinder head assembly.

NOTE:

VVEL ladder assembly cannot be replaced as a single part, because it is machined together with cylinder head assembly.

INSPECTION AFTER ASSEMBLY

Inspection of Camshaft Sprocket (INT) Oil Groove

CAUTION:

- Perform this inspection only when DTC P0011, P0012 is detected in self-diagnostic results of CONSULT-III and it is directed according to inspection procedure of EC section. Refer to [EC-706, "Diagnosis Description"](#).

- Check when engine is cold to prevent burns from the splashing engine oil.

1. Check engine oil level. Refer to [LU-25, "Inspection"](#).
2. Perform the following procedure to prevent the engine from being unintentionally started while checking.
 - a. Release the fuel pressure. Refer to [EC-1228, "Inspection"](#).
 - b. Disconnect ignition coil and injector harness connectors. Refer to [EM-191, "Exploded View"](#).
 3. Remove valve timing control solenoid valve. Refer to [EM-212, "Exploded View"](#).
4. Crank engine, and then check that engine oil comes out from valve timing control solenoid valve hole (A). End crank after checking.

1 : Valve timing control cover (bank 2)

WARNING:

Be careful not to touch rotating parts (drive belt, idler pulley, and crankshaft pulley, etc.).

CAUTION:

- Prevent splashing by using a shop cloth to prevent the worker from injury from engine oil and to prevent engine oil contamination.
 - Prevent splashing by using a shop cloth to prevent engine oil from being splashed to engine and vehicle. Especially, be careful not to apply engine oil to rubber parts of drive belt, engine mounting insulator, etc. Wipe engine oil out immediately if it is splashed.
5. Perform the following inspection if engine oil does not come out from valve timing control solenoid valve oil hole of the valve timing control cover.
 - Remove oil filter, and then clean it. Refer to [EM-212, "Exploded View"](#).
 - Clean oil groove between oil strainer and valve timing control solenoid valve. Refer to [LU-21, "Engine Lubrication System"](#) and [LU-22, "Engine Lubrication System Schematic"](#).
 6. Remove components between valve timing control solenoid valve and camshaft sprocket, and then check each oil groove for clogging.
 - Clean oil groove if necessary. Refer to [LU-21, "Engine Lubrication System"](#) and [LU-22, "Engine Lubrication System Schematic"](#).
 7. After inspection, install removed parts in the reverse order.

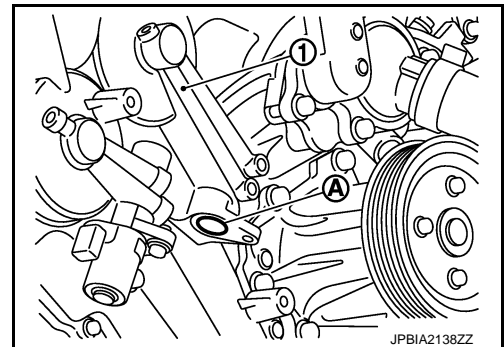

Inspection for Leakage

CAMSHAFT

[VK50VE]

< UNIT DISASSEMBLY AND ASSEMBLY >

The following are procedures for checking fluid leakage, lubricant leakage.

- Before starting engine, check oil/fluid levels including engine coolant and engine oil. If any are less than the required quantity, fill them to the specified level. Refer to [MA-12, "Fluids and Lubricants"](#).
- Follow the procedure below to check for fuel leakage.
 - Turn ignition switch to the "ON" position (with engine stopped). With fuel pressure applied to fuel piping, check for fuel leakage at connection points.
 - Start engine. With engine speed increased, check again for fuel leakage at connection points.
- Run engine to check for unusual noise and vibration.

NOTE:

If hydraulic pressure inside chain tensioner drops after removal/installation, slack in guide may generate a pounding noise during and just after the engine start. However, this does not indicate a malfunction. The noise will stop after hydraulic pressure rises.

- Warm up engine thoroughly to check that there is no leakage of fuel, or any oil/fluids including engine oil and engine coolant.
- Bleed air from lines and hoses of applicable lines, such as in cooling system.
- After cooling down engine, again check oil/fluid levels including engine oil and engine coolant. Refill them to the specified level, if necessary.

Summary of the inspection items:

Items	Before starting engine	Engine running	After engine stopped
Engine coolant	Level	Leakage	Level
Engine oil	Level	Leakage	Level
Other oils and fluids*	Level	Leakage	Level
Fuel	Leakage	Leakage	Leakage

* Transmission/transaxle/CVT fluid, power steering fluid, brake fluid, etc.

CYLINDER HEAD

< UNIT DISASSEMBLY AND ASSEMBLY >

[VK50VE]

CYLINDER HEAD

Exploded View

INFOID:000000003733453

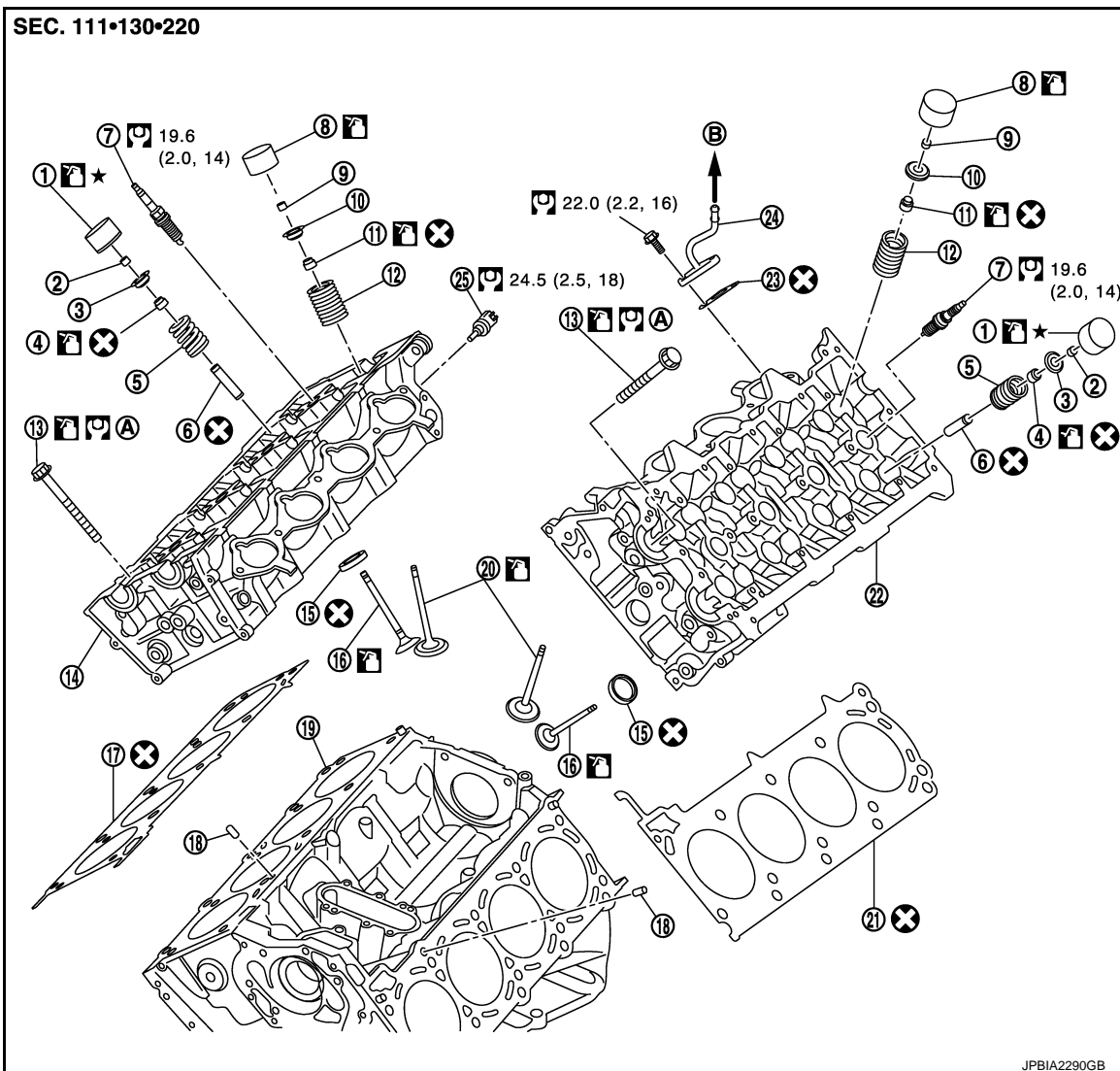

- | | | |
|---------------------------------------|--|---|
| 1. Valve lifter (EXH) | 2. Valve collet (EXH) | 3. Valve spring retainer (EXH) |
| 4. Valve oil seal (EXH) | 5. Valve spring (with valve spring seat) (EXH) | 6. Valve guide (EXH) |
| 7. Spark plug | 8. Valve seat (INT) | 9. Valve collet (INT) |
| 10. Valve spring retainer (INT) | 11. Valve oil seal (INT) | 12. Valve spring (with valve spring seat) (INT) |
| 13. Cylinder head bolt | 14. Cylinder head (bank 2) | 15. Valve seat (EXH) |
| 16. Valve (EXH) | 17. Cylinder head gasket (bank 2) | 18. Oil filter (for VVEL ladder assembly) |
| 19. Cylinder block | 20. Valve (INT) | 21. Cylinder head gasket (bank 1) |
| 22. Cylinder head (bank 1) | 23. Gasket | 24. Water pipe |
| 25. Engine coolant temperature sensor | | |

A. Refer to [EM-246](#)

B. To Electric throttle control actuator (bank 1)

Refer to [GI-4, "Components"](#) for symbol marks in the figure.

CAUTION:

A high degree of precision is required for a valve on the intake side. Never remove the valve related parts unless necessary.

CYLINDER HEAD

< UNIT DISASSEMBLY AND ASSEMBLY >

[VK50VE]

NOTE:

- As for replacement of parts on the intake side as shown in the exploded view, replace VVEL ladder assembly & cylinder head assembly. (Only valve oil seals are replaceable as a single part.)
- VVEL ladder assembly cannot be replaced as a single part, because it is machined together with cylinder head assembly.

Disassembly and Assembly

INFOID:000000003733454

DISASSEMBLY

1. Remove the following parts:
 - Rocker cover and spark plug: Refer to [EM-191, "Exploded View"](#).
 - Intake manifold: Refer to [EM-179, "Exploded View"](#).
 - Exhaust manifold: Refer to [EM-205, "Exploded View"](#).
 - Water inlet and thermostat housing: Refer to [CO-46, "Exploded View"](#).
 - Water pipe and heater pipe: Refer to [CO-46, "Exploded View"](#).
 - Timing chain: Refer to [EM-212, "Exploded View"](#).
 - Camshaft (EXH) and VVEL ladder assembly: Refer to [EM-227, "Exploded View"](#).
2. Remove cylinder head.
 - Loosen mounting bolts in reverse order as shown in the figure.

A : Bank 2

B : Bank 1

⇐ : Engine front

- Use TORX socket and power tool.

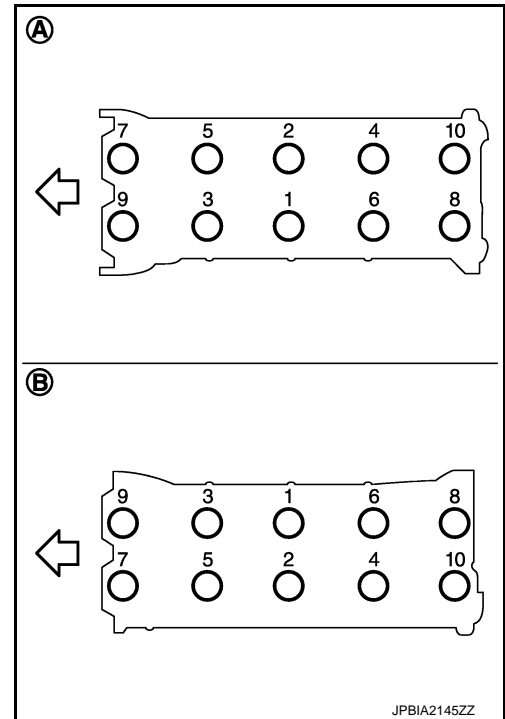

JPBIA2145ZZ

3. Remove cylinder head gaskets.
4. Remove oil filter (for VVEL ladder assembly) from cylinder block, if necessary.
5. Remove valve lifter.
 - Identify installation positions, and store them without mixing them up.
6. Remove valve collet.
 - Compress valve spring with the valve spring compressor [SST: KV10116200 (J-26336-A)] (A), the attachment [SST: KV10115900 (J-26336-20)] (C) and the adapter [SST: KV10109220 (—)] (B). Remove valve collet with a magnet hand.

CAUTION:

When working, take care not to damage valve lifter holes.

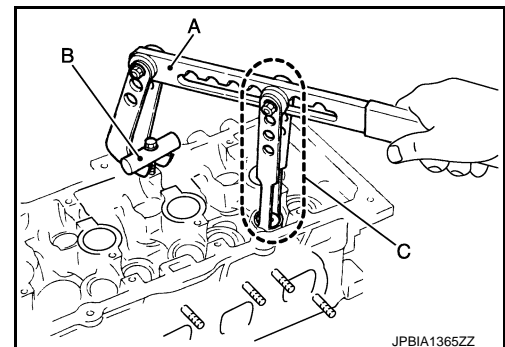

JPBIA1365ZZ

7. Remove valve spring retainer and valve spring (with valve spring seat).

CYLINDER HEAD

< UNIT DISASSEMBLY AND ASSEMBLY >

[VK50VE]

8. Push valve stem to combustion chamber side, and remove valve.
 - Identify installation positions, and store them without mixing them up.
9. Remove valve oil seal using the valve oil seal puller [SST: KV10107902 (J38959)] (A).

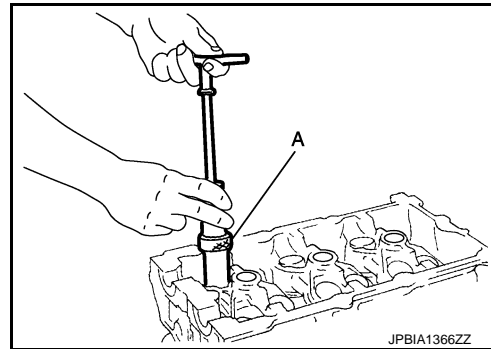

10. Remove valve seat (EXH), if valve seat (EXH) must be replaced.
 - Bore out old seat until it collapses. Boring should not continue beyond the bottom face of the seat recess in cylinder head. Set the machine depth stop to ensure this. Refer to [EM-285, "Cylinder Head"](#).

CAUTION:

Prevent to scratch cylinder head by excessive boring.

11. Remove valve guide (EXH), if valve guide (EXH) must be replaced.
 - a. To remove valve guide (EXH), heat cylinder head to 110 to 130°C (230 to 266°F) by soaking in heated oil (A).

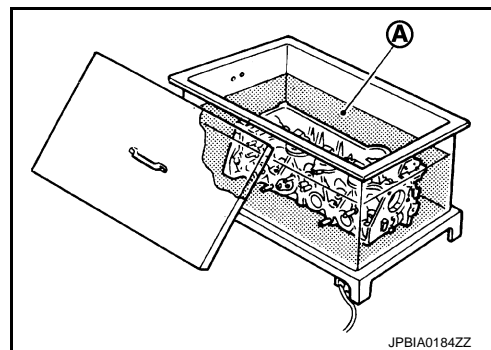

- b. Drive out valve guide (EXH) with a press [under a 20 kN (2 ton, 2.2 US ton, 2.0 Imp ton) pressure] or a hammer and the valve guide drift (commercial service tool).

WARNING:

Cylinder head contains heat. When working, wear protective equipment to avoid getting burned.

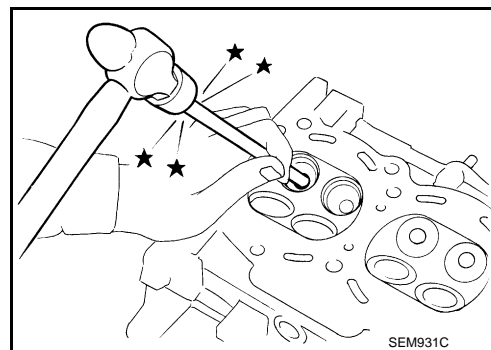

ASSEMBLY

1. Install valve guide (EXH), if removed.

Replace with oversized [0.2 mm (0.008 in)] valve guide (EXH).

 - a. Using the valve guide reamer (commercial service tool) (A), ream cylinder head valve guide (EXH) hole.

Oversize (service) [0.2 mm (0.008 in)]:

: Refer to [EM-285, "Cylinder Head"](#).

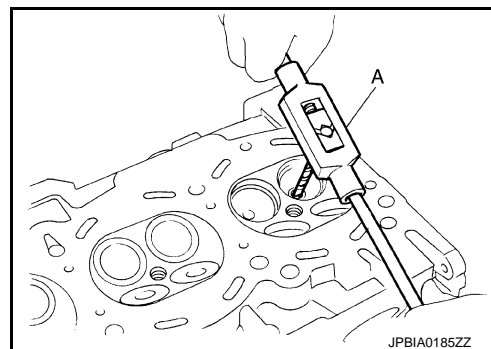

A
EM
C
D
E
F
G
H
I
J
K
L
M
N
O
P

CYLINDER HEAD

< UNIT DISASSEMBLY AND ASSEMBLY >

[VK50VE]

- b. Heat cylinder head to 110 to 130°C (230 to 266°F) by soaking in heated oil (A).

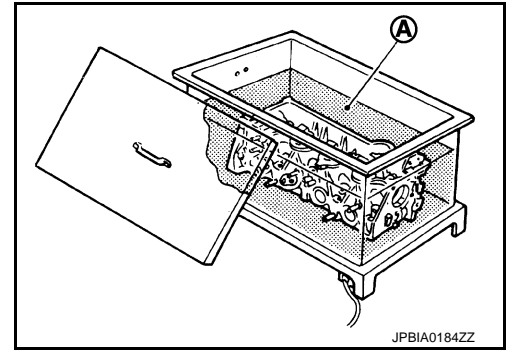

- c. Using the valve guide drift (commercial service tool), press valve guide (EXH) from camshaft side to the dimensions as shown in the figure.

Projection (A)

: Refer to [EM-285, "Cylinder Head"](#).

WARNING:

Cylinder head contains heat. When working, wear protective equipment to avoid getting burned.

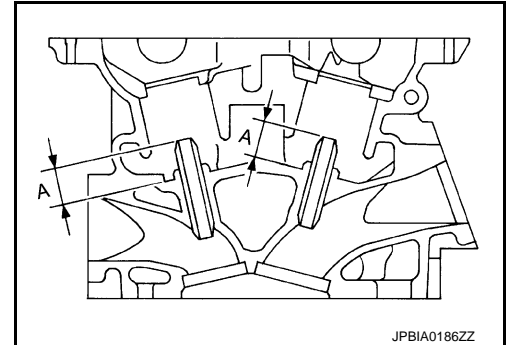

- d. Using the valve guide reamer (commercial service tool) (A), apply reamer finish to valve guide (EXH).

Standard

: Refer to [EM-285, "Cylinder Head"](#).

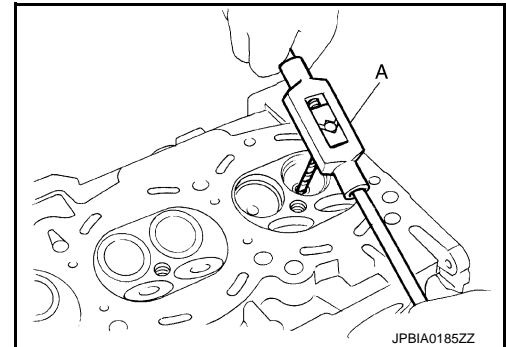

2. Install valve seat (EXH), if removed.
Replace with oversize [0.5 mm (0.020 in)] valve seat (EXH).

- a. Ream cylinder head recess diameter (a) for service valve seat (EXH).

Oversize (service) [0.5 mm (0.020 in)]:

: Refer to [EM-285, "Cylinder Head"](#).

- Be sure to ream in circles concentric to valve guide center. This enables valve to fit correctly.

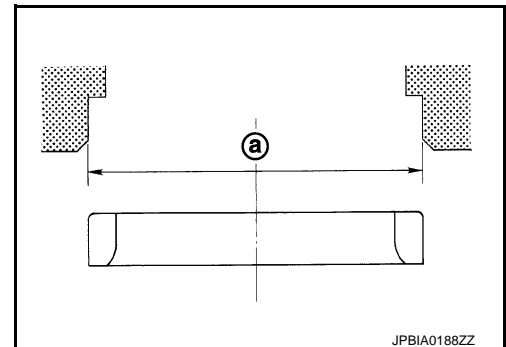

CYLINDER HEAD

< UNIT DISASSEMBLY AND ASSEMBLY >

[VK50VE]

- b. Heat cylinder head to 110 to 130°C (230 to 266°F) by soaking in heated oil (A).

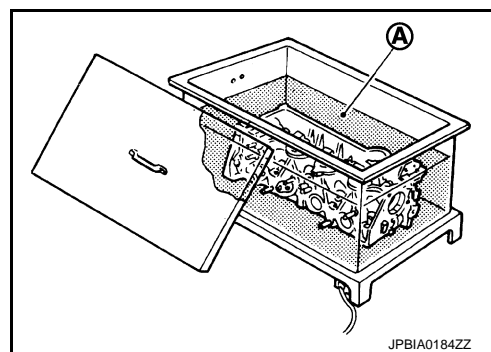

- c. Provide valve seats (EXH) cooled well with dry ice. Force fit valve seat (EXH) into cylinder head.

WARNING:

Cylinder head contains heat. When working, wear protective equipment to avoid getting burned.

CAUTION:

Avoid directly touching cold valve seats.

- d. Using the valve seat cutter set (commercial service tool) or valve seat grinder, finish seat to the specified dimensions. Refer to [EM-285, "Cylinder Head"](#).

CAUTION:

When using the valve seat cutter, firmly grip cutter handle with both hands. Then, press on the contacting surface all around the circumference to cut in a single drive. Improper pressure on cutter or cutting many different times may result in staged valve seat.

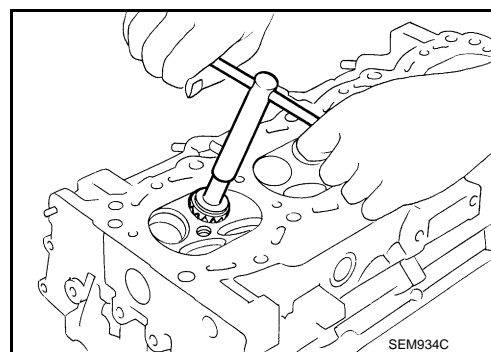

- e. Using compound, grind to adjust valve fitting.

- f. Check again for normal contact. Refer to [EM-251, "Inspection"](#).

3. Install new valve oil seals as per the following:

- a. Apply new engine oil on new valve oil seal joint and seal lip.

- b. Using the valve oil seal drift [SST: KV10115600 (J-38958)] (A), press fit valve seal to height (b) shown in figure.

Height (b)

Intake : 14.3 - 14.9 mm (0.563 - 0.587 in)

Exhaust : 13.6 - 14.2 mm (0.535 - 0.559 in)

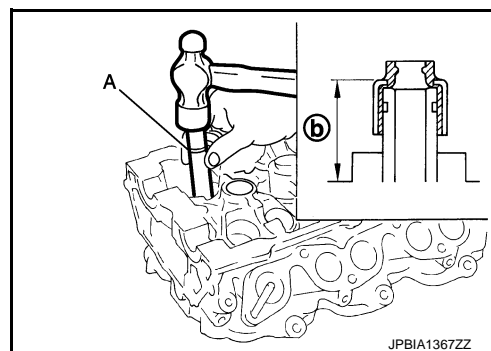

4. Install valve.

NOTE:

Larger diameter valves are for intake side.

CYLINDER HEAD

< UNIT DISASSEMBLY AND ASSEMBLY >

[VK50VE]

5. Install oil filter (for VVEL ladder assembly) (1) in the direction shown in the figure, if removed.
 - Check that the oil filter does not protrude from the upper surface of cylinder block (2) after installation.

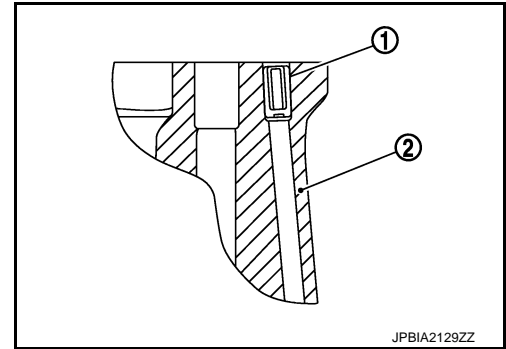

JPBIA2129ZZ

6. Install new cylinder head gaskets.
7. Install cylinder head as per the following:

CAUTION:

- If cylinder head bolts are re-used, check their outer diameters before installation. Refer to [EM-251, "Inspection"](#).
- Before installing cylinder head, inspect cylinder head distortion. Refer to [EM-251, "Inspection"](#).
- Tighten cylinder head bolts in numerical order as shown in figure.

- A : Bank 2
- B : Bank 1
- ← : Engine front

- Use TORX socket.

- a. Apply new engine oil to threads and seat surfaces of cylinder head bolts.
- b. Tighten all cylinder head bolts.

: 40 N·m (4.1 kg·m, 30 ft·lb)

- c. Tighten all cylinder head bolts (clockwise).

Angle tightening: 75 degrees

- d. Completely loosen all cylinder head bolts.

: 0 N·m (0 kg·m, 0 ft·lb)

CAUTION:

In step "d", loosen bolts in the reverse order of that indicated in the figure.

- e. Tighten all cylinder head bolts.

: 40.0 N·m (4.1 kg·m, 30 ft·lb)

- f. Tighten all cylinder head bolts (clockwise).

Angle tightening: 65 degrees

CAUTION:

Check the tightening angle using the angle wrench [SST: KV10112100 (BT8653-A)] (A). Never make judgment by visual inspection.

- Check tightening angle indicated on the angle wrench indicator plate.

- g. Tighten all cylinder head bolts again (clockwise).

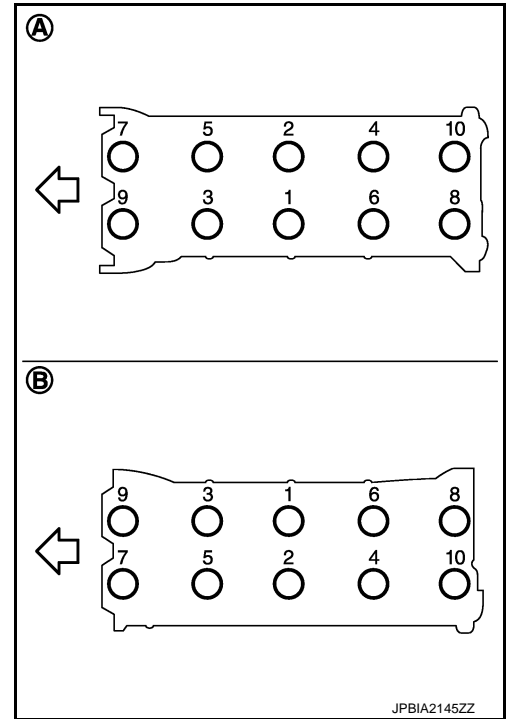

JPBIA2145ZZ

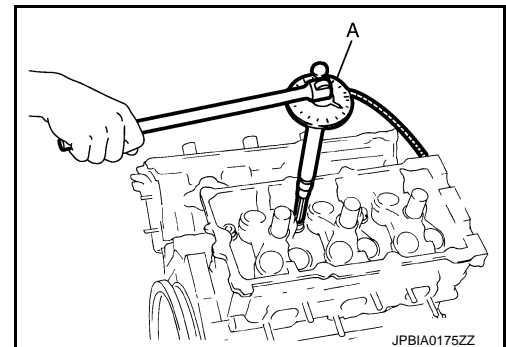

JPBIA0175ZZ

CYLINDER HEAD

< UNIT DISASSEMBLY AND ASSEMBLY >

[VK50VE]

Angle tightening: 65 degrees

8. Install valve spring (with valve spring seat).
 - Install narrow pitch (B) end [paint mark (C)] to cylinder head side (valve spring seat side).

A : Wide pitch

⇐ : Cylinder head side

Paint mark color

Intake : Yellow

Exhaust : Pink

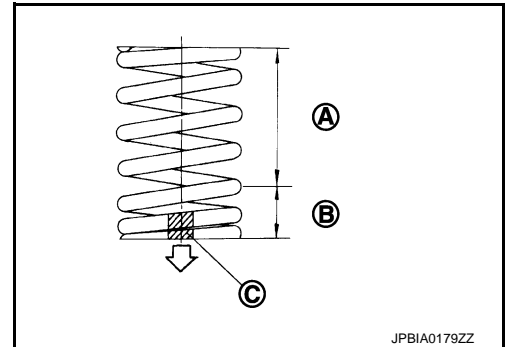

9. Install valve spring retainer.

10. Install valve collet.

- Compress valve spring with the valve spring compressor [SST: KV10116200 (J26336-A)] (A), the attachment [SST: KV10115900 (J26336-20)] (C) and the adapter [SST: KV10109220 (—)] (B). Install valve collet with a magnet hand.

CAUTION:

When working, take care not to damage valve lifter holes.

- Tap valve stem edge lightly with plastic hammer after installation to check its installed condition.

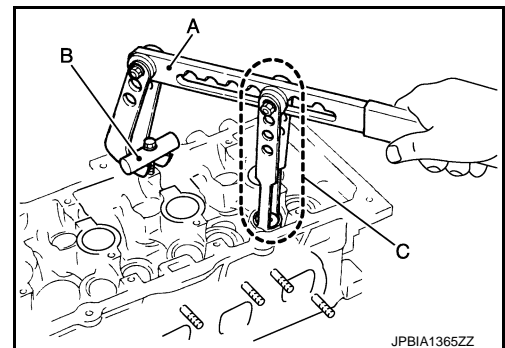

11. Install valve lifter.

- Install it in the original position.

12. Install in the reverse order of removal.

Inspection

INFOID:000000003733455

INSPECTION AFTER DISASSEMBLY

Cylinder Head Bolts Outer Diameter

- Cylinder head bolts are tightened by plastic zone tightening method. Whenever the size difference between (B) and (A) exceeds the limit, replace them with new one.

Limit [(B) - (A)] : 0.18 mm (0.0071 in)

c : 55 mm (2.17 in)

d : 12 mm (0.47 in)

- If reduction of outer diameter appears in a position other than (A), use it as (A) point.

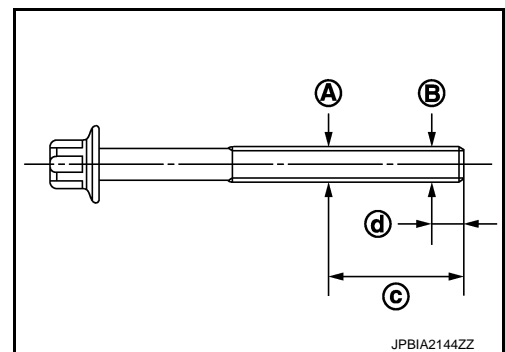

Cylinder Head Distortion

NOTE:

When performing this inspection, cylinder block distortion should be also checked. Refer to [EM-265, "Inspection"](#).

1. Using a scraper, wipe out oil, scale, gasket, sealant and carbon deposits from surface of cylinder head.

CAUTION:

Never allow gasket fragments to enter engine oil or engine coolant passages.

CYLINDER HEAD

< UNIT DISASSEMBLY AND ASSEMBLY >

[VK50VE]

2. At each of several locations on bottom surface of cylinder head, measure the distortion in six directions (A, B, C, D, E, F).

Limit : Refer to [EM-285, "Cylinder Head"](#).

- If it exceeds the limit, replace VVEL ladder assembly & cylinder head assembly.

NOTE:

Cylinder head assembly cannot be replaced as a single part, because it is machined together with VVEL ladder assembly.

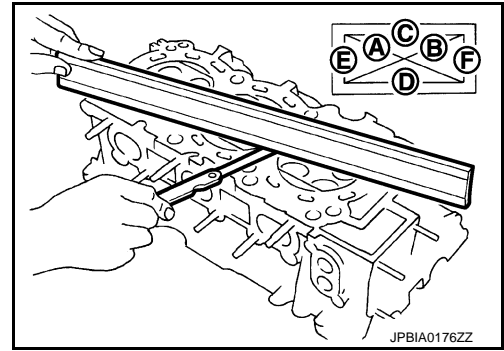

Valve Dimensions

- Check the dimensions of each valve. For the dimensions, refer to [EM-285, "Cylinder Head"](#).
- If dimensions are out of the standard.
 - Replace valve (EXH) and check valve seat contact. Refer to "VALVE SEAT CONTACT". (Exhaust side)
 - Replace VVEL ladder assembly & cylinder head assembly. Refer to [EM-227, "Exploded View"](#). (Intake side)

NOTE:

Since the valve (INT) cannot be replaced by the piece, VVEL ladder assembly & cylinder head assembly replacement are required.

Valve Guide Clearance

Valve Stem Diameter

- Measure the diameter of valve stem with micrometer (A).

Standard : Refer to [EM-285, "Cylinder Head"](#).

Valve Guide Inner Diameter

- Measure the inner diameter of valve guide with bore gauge.

Standard : Refer to [EM-285, "Cylinder Head"](#).

Valve Guide Clearance

- (Valve guide clearance) = (Valve guide inner diameter) – (Valve stem diameter)

Standard : Refer to [EM-285, "Cylinder Head"](#).

- If the calculated value exceeds the limit.
 - Replace valve (EXH) and/or valve guide (EXH). Refer to [EM-245, "Exploded View"](#). (Exhaust side)
 - Replace VVEL ladder assembly & cylinder head assembly. Refer to [EM-227, "Exploded View"](#). (Intake side)

NOTE:

Since the valve (INT) and valve guide (INT) cannot be replaced by the piece, VVEL ladder assembly & cylinder head assembly replacement are required.

Valve Seat Contact

- After confirming that the dimensions of valve guides and valves are within the specifications, perform this procedure.
- Apply prussian blue (or white lead) onto contacting surface of valve seat to check the condition of the valve contact on the surface.
- Check if the contact area band is continuous all around the circumference.

- A : OK
- B : NG

- If not, grind to adjust valve fitting and check again. If the contacting surface still has "NG" conditions even after the re-check, replace valve seat (EXH). Refer to [EM-245, "Exploded View"](#). (Exhaust side)
- If not, replace VVEL ladder assembly & cylinder head assembly. Refer to [EM-227, "Exploded View"](#). (Intake side)

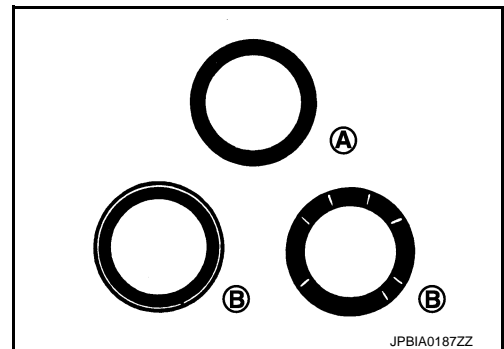
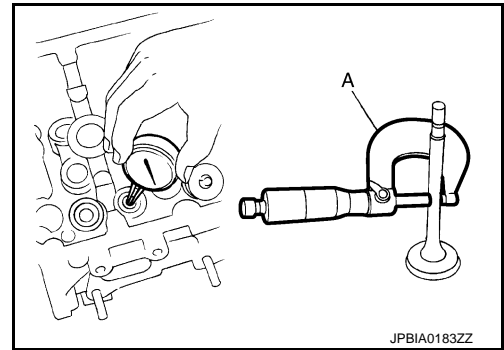

CYLINDER HEAD

< UNIT DISASSEMBLY AND ASSEMBLY >

[VK50VE]

NOTE:

Since the valve seat (INT) cannot be replaced by the piece, VVEL ladder assembly & cylinder head assembly replacement are required.

Valve Spring (with valve spring seat) Squareness

- Set a try square (A) along the side of valve spring (with valve spring seat) and rotate spring. Measure the maximum clearance between the top of spring and try square.

B : Contact

Limit : Refer to [EM-285, "Cylinder Head"](#).

- If it exceeds the limit.
- Replace valve spring (with valve spring seat) (EXH). Refer to [EM-245, "Exploded View"](#). (Exhaust side)
- Replace VVEL ladder assembly & cylinder head assembly. Refer to [EM-227, "Exploded View"](#). (Intake side)

NOTE:

Since the valve spring (with valve spring seat) (INT) cannot be replaced by the piece, VVEL ladder assembly & cylinder head assembly replacement are required.

Valve Spring Dimensions and Valve Spring Pressure Load

- Check the valve spring (with valve spring seat) pressure at specified spring height.

Standard

: Refer to [EM-285, "Cylinder Head"](#).

- If the installation load or load with valve open is out of the standard.
- Replace valve spring (with valve spring seat) (EXH). Refer to [EM-245, "Exploded View"](#). (Exhaust side)
- Replace VVEL ladder assembly & cylinder head assembly. Refer to [EM-227, "Exploded View"](#). (Intake side)

NOTE:

Since the valve spring (with valve spring seat) (INT) cannot be replaced by the piece, VVEL ladder assembly & cylinder head assembly replacement are required.

INSPECTION AFTER ASSEMBLY

Inspection for Leakage

The following are procedures for checking fluid leakage, lubricant leakage.

- Before starting engine, check oil/fluid levels including engine coolant and engine oil. If any are less than the required quantity, fill them to the specified level. Refer to [MA-12, "Fluids and Lubricants"](#).
- Follow the procedure below to check for fuel leakage.
- Turn ignition switch to the "ON" position (with engine stopped). With fuel pressure applied to fuel piping, check for fuel leakage at connection points.
- Start engine. With engine speed increased, check again for fuel leakage at connection points.
- Run engine to check for unusual noise and vibration.

NOTE:

If hydraulic pressure inside chain tensioner drops after removal/installation, slack in guide may generate a pounding noise during and just after the engine start. However, this does not indicate a malfunction. The noise will stop after hydraulic pressure rises.

- Warm up engine thoroughly to check that there is no leakage of fuel, or any oil/fluids including engine oil and engine coolant.
- Bleed air from lines and hoses of applicable lines, such as in cooling system.
- After cooling down engine, again check oil/fluid levels including engine oil and engine coolant. Refill them to the specified level, if necessary.

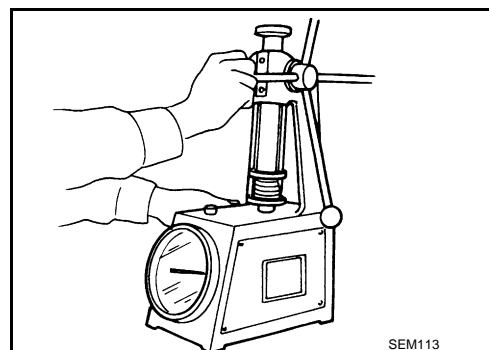
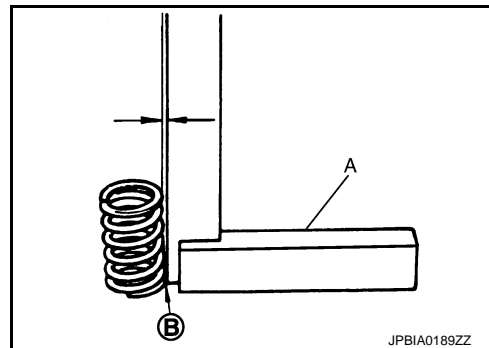

CYLINDER HEAD

< UNIT DISASSEMBLY AND ASSEMBLY >

[VK50VE]

Summary of the inspection items:

Items	Before starting engine	Engine running	After engine stopped
Engine coolant	Level	Leakage	Level
Engine oil	Level	Leakage	Level
Other oils and fluids*	Level	Leakage	Level
Fuel	Leakage	Leakage	Leakage

* Transmission/transaxle/CVT fluid, power steering fluid, brake fluid, etc.

CYLINDER BLOCK

< UNIT DISASSEMBLY AND ASSEMBLY >

[VK50VE]

CYLINDER BLOCK

Exploded View

INFOID:000000003733456

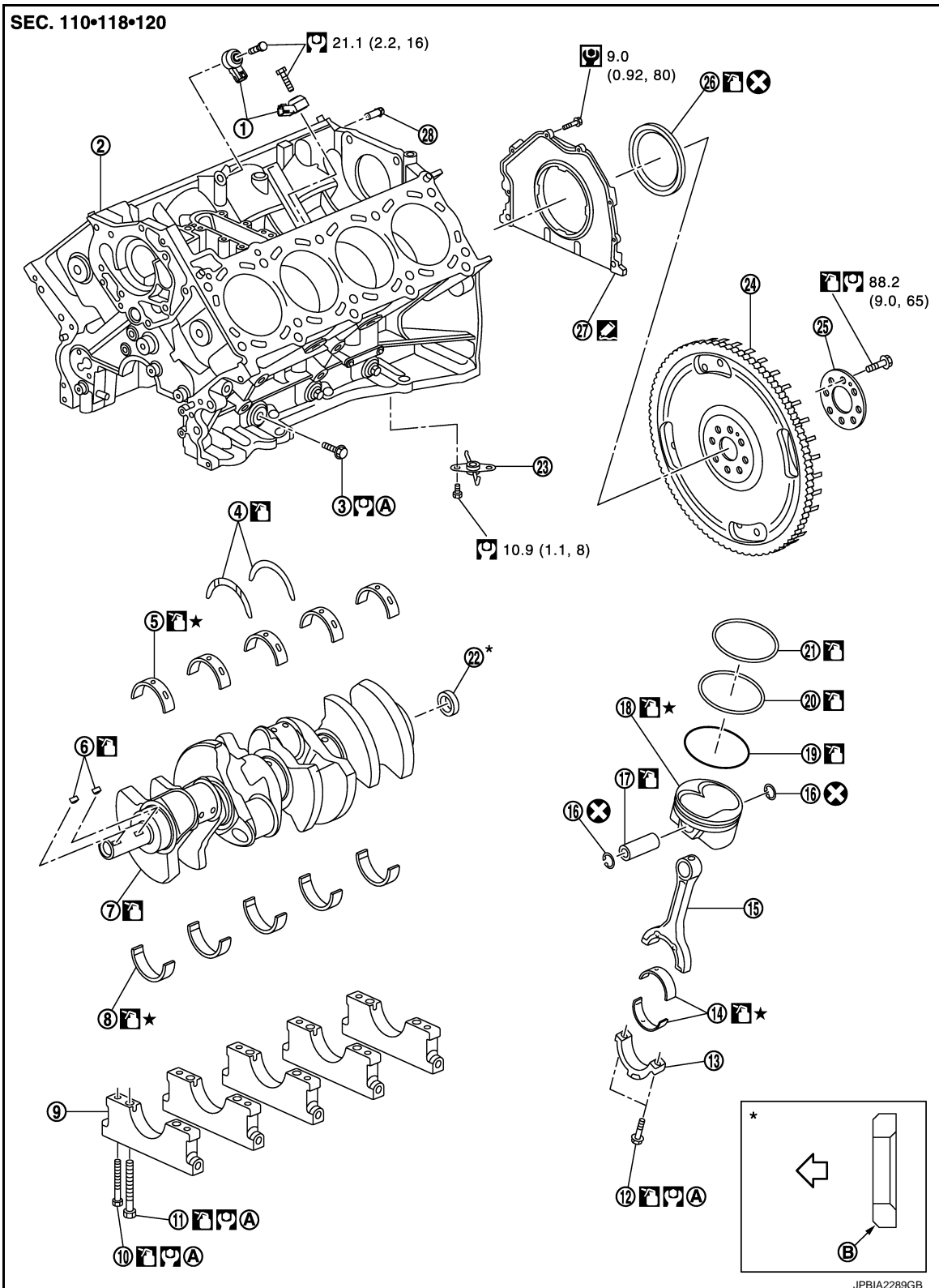

- 1. Knock sensor
- 4. Thrust bearing
- 7. Crankshaft

- 2. Cylinder block
- 5. Main bearing (upper)
- 8. Main bearing (lower)

- 3. Side bolt
- 6. Crankshaft key
- 9. Main bearing cap

A
EM
C
D
E
F
G
H
I
J
K
L
M
N
O
P

CYLINDER BLOCK

[VK50VE]

< UNIT DISASSEMBLY AND ASSEMBLY >

- | | | |
|--|----------------------------|-----------------------------|
| 10. Main bearing cap sub bolt | 11. Main bearing cap bolt | 12. Connecting rod cap bolt |
| 13. Connecting rod cap | 14. Connecting rod bearing | 15. Connecting rod |
| 16. Snap ring | 17. Piston pin | 18. Piston |
| 19. Oil ring | 20. Second ring | 21. Top ring |
| 22. Pilot converter | 23. Piston oil jet | 24. Drive plate |
| 25. Reinforcement plate | 26. Rear oil seal | 27. Rear oil seal retainer |
| 28. Cylinder block heater (for Canada) | | |
| A. Refer to EM-256 | B. Chamfered | |

↶ : Crankshaft side

Refer to [GI-4, "Components"](#) for symbol marks in the figure.

Disassembly and Assembly

INFOID:000000003733457

DISASSEMBLY

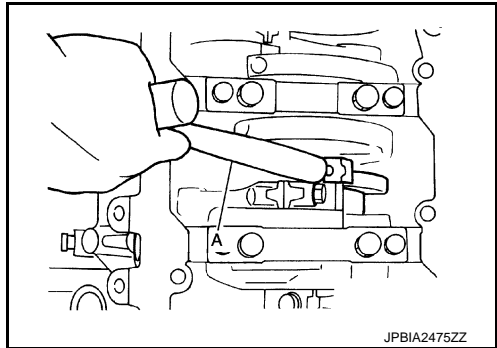
- Remove the following parts:
 - Oil pans (lower and upper): Refer to [EM-208, "Exploded View"](#).
 - Front cover and timing chain: Refer to [EM-212, "Exploded View"](#).
 - Cylinder head: Refer to [EM-245, "Exploded View"](#).
 - Remove knock sensor.
CAUTION:
Carefully handle knock sensor avoiding shocks.
 - Remove oil filter (for VVEL ladder assembly) from cylinder block, if necessary. Refer to [EM-245, "Exploded View"](#).
 - Remove piston and connecting rod assembly as per the following:
 - Before removing piston and connecting rod assembly, check the connecting rod side clearance. Refer to [EM-265, "Inspection"](#).
 - CAUTION:**
Be careful not to drop connecting rod bearing, and to scratch the surface.
 - Position crankshaft pin corresponding to connecting rod to be removed onto the bottom dead center.
 - Loosen mounting bolts, and remove connecting rod bearing cap.
 - Using a hammer handle (A) or similar tool, push piston and connecting rod assembly out to the cylinder head side.
CAUTION:
Be careful not to damage the cylinder wall and crankshaft pin, resulting from an interference of the connecting rod big end.
- 
- JPBIA2475ZZ
- Remove connecting rod bearings from connecting rod and connecting rod bearing cap.
CAUTION:
 - Be careful not to drop connecting rod bearing, and to scratch the surface.
 - Identify installation positions, and store them without mixing them up.
 - Remove piston rings from piston.
 - Before removing piston rings, check the piston ring side clearance. Refer to [EM-265, "Inspection"](#).

CYLINDER BLOCK

< UNIT DISASSEMBLY AND ASSEMBLY >

[VK50VE]

- Use a piston ring expander (commercial service tool) (A).

CAUTION:

- **When removing piston rings, be careful not to damage piston.**
- **Be careful not to damage piston rings by expanding them excessively.**

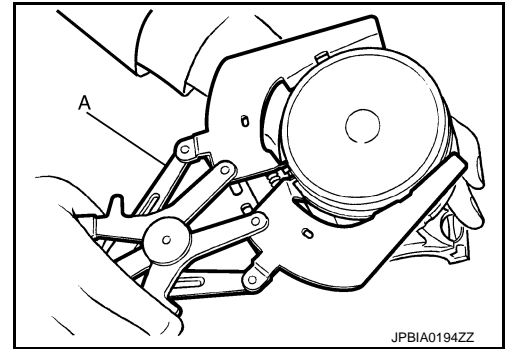

7. Remove piston from connecting rod as per the following:
 - a. Using snap ring pliers (A), remove snap rings.

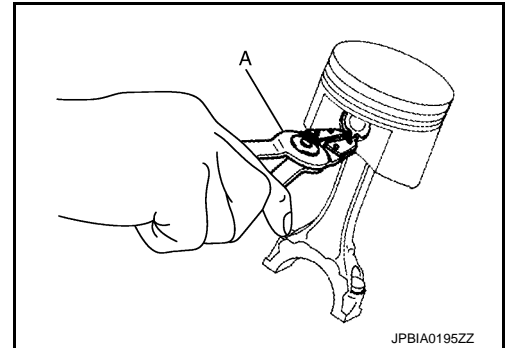

- b. Heat piston to 60 to 70°C (140 to 158°F) with an industrial use dryer (A) or an equivalent.

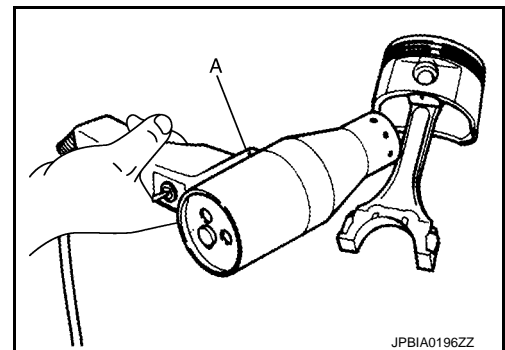

- c. Push out piston pin using a stick that has an outer diameter of approximately 20 mm (0.79 in).

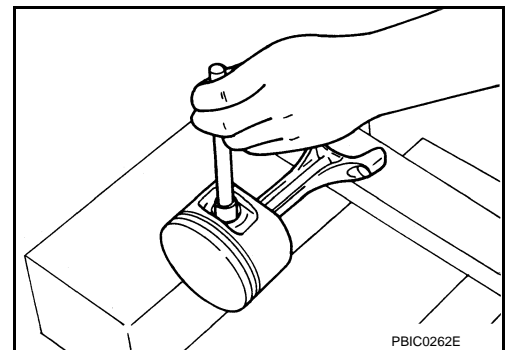

8. Remove rear oil seal and rear oil seal retainer assembly from cylinder block.
 - Insert screwdriver or similar tool between rear end of crankshaft counter weight and rear oil seal retainer, and separate liquid gasket to remove.

CAUTION:
Be careful not to damage the mating surfaces.
9. Using screwdriver or similar tool, and lever off rear oil seal from rear oil seal retainer.
10. Remove main bearing cap as per the following:
 - Before loosening cylinder block bolts, measure the crankshaft end play. Refer to [EM-265, "Inspection"](#).

A
EM
C
D
E
F
G
H
I
J
K
L
M
N
O
P

CYLINDER BLOCK

[VK50VE]

< UNIT DISASSEMBLY AND ASSEMBLY >

- a. Loosen side bolts starting from No. 30 to 21 to remove.

⇐ : Engine front

- b. Loosen main bearing cap sub bolts starting from No. 20 to 11 to remove.
c. Loosen main bearing cap bolts starting from No. 10 to 1 to remove.

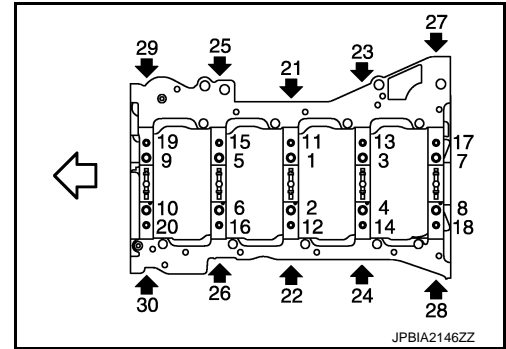

- d. Remove the main bearing cap.
• Insert bolts (1) into bolt holes, and then remove main bearing cap (2) by lifting up and shaking forward and backward.

CAUTION:

Be careful not to damage the mounting surface.

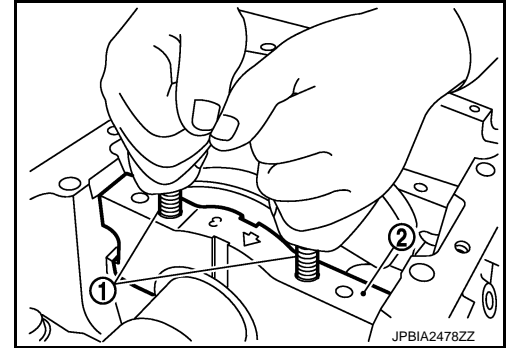

11. Remove crankshaft.
12. Remove main bearings and thrust bearings from main bearing cap and cylinder block.
CAUTION:
• **Be careful not to drop main bearing, and to scratch the surface.**
• **Identify installation positions, and store them without mixing them up.**
13. Remove pilot converter using the pilot bushing puller (commercial service tool), if necessary.
14. Remove oil jet.

ASSEMBLY

1. Fully air-blow engine coolant and engine oil passages in cylinder block, cylinder bore and crankcase to remove any foreign material.

CAUTION:

Use goggles to protect your eyes.

CYLINDER BLOCK

< UNIT DISASSEMBLY AND ASSEMBLY >

[VK50VE]

2. Install each plug to cylinder block as shown in the figure.

↶ : Engine front

- Tighten each plug as specified below.

Part	Tightening torque
Plug (2)	78.0 N·m (8.0 kg·m, 58 ft·lb)
Water drain plug (3)	19.6 N·m (2.0 kg·m, 14 ft·lb)
Plug (4)	65.0 N·m (6.6 kg·m, 48 ft·lb)

- Replace washers (1), (5) with new ones.
- Apply sealant to the thread of water drain plug (3).
Use Genuine RTV Silicone Sealant or an equivalent. Refer to [GI-15, "Recommended Chemical Products and Sealants"](#).
- Apply sealant to the thread of plug (4).
Use Genuine High Strength Thread Locking Sealant or an equivalent. Refer to [GI-15, "Recommended Chemical Products and Sealants"](#).

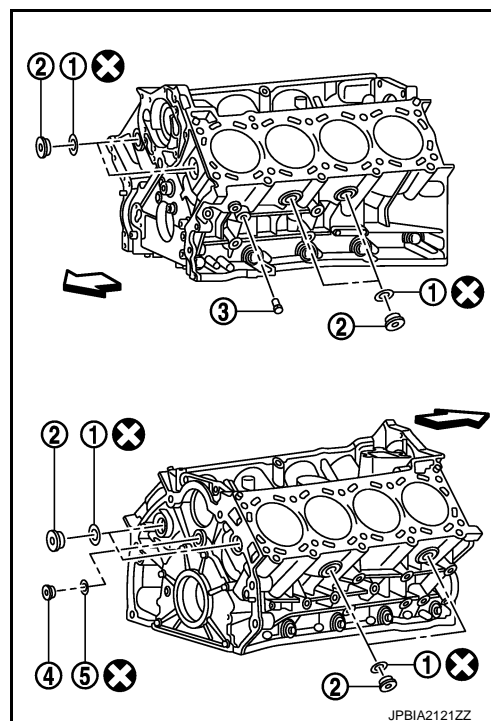

3. Install oil jet.

- Insert oil jet into cylinder block hole, and tighten the mounting bolt on the corner side (A) first.

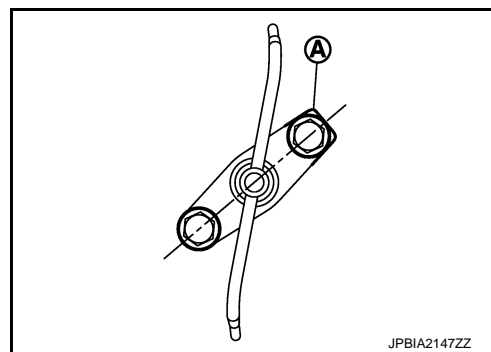

4. Install pilot converter to crankshaft, if removed.

- With drift [outer diameter: approx. 35 mm (1.38 in)], press-fit as far as it will go.

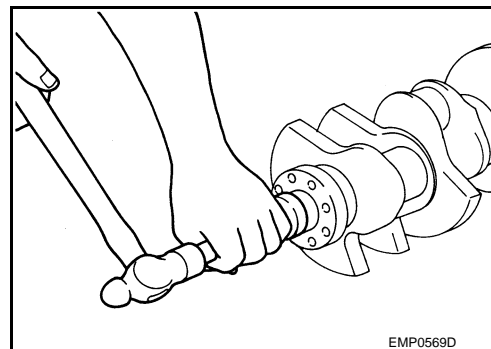

CYLINDER BLOCK

< UNIT DISASSEMBLY AND ASSEMBLY >

[VK50VE]

- Press-fit pilot converter with its chamfering side facing crankshaft as shown in the figure.

⇐ : Crankshaft side

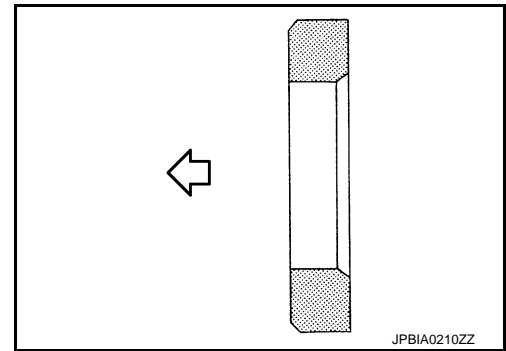

5. Install main bearings and thrust bearings as per the following:

CAUTION:

Be careful not to drop main bearing, and to scratch the surface.

- Remove dust, dirt, and engine oil on bearing mating surfaces of cylinder block and main bearing caps.
- Install thrust bearings (2) to both sides of the No. 3 journal housing on cylinder block (1).

- 3 : Main bearing (upper) (cylinder block side)
- 4 : Crankshaft
- 5 : Main bearing (lower) (main bearing cap side)

⇐ : Engine front

- Install thrust bearings with the oil groove (A) facing crankshaft arm (outside).
- Install main bearings paying attention to the direction.
 - Main bearing with oil hole (B) and groove (C) goes on cylinder block. The one without them goes on main bearing cap.
 - Before installing main bearings, apply engine oil to the bearing surface (inside). Do not apply engine oil to the back surface, but thoroughly clean it.
 - When installing, align main bearing stopper protrusion to cut-out of cylinder block and main bearing.
 - Ensure the oil holes on cylinder block and those on the corresponding bearing are aligned.

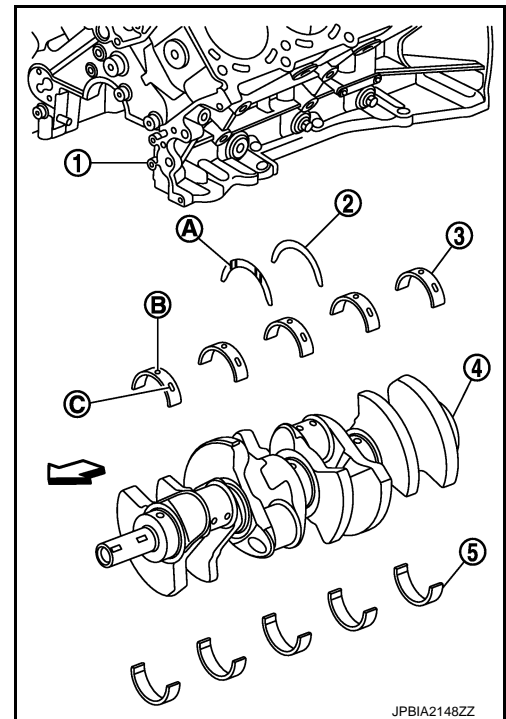

6. Install crankshaft to cylinder block.

- While turning crankshaft by hand, check that it turns smoothly.

7. Install main bearing caps as per the following:

- Align the identification number to the journal position to install.

⇐ : Engine front

- Install it with the front mark (indicated by stamping) facing the front of engine.
- Using plastic hammer or similar tool, tap them lightly to seat them on the installation position.

NOTE:

Main bearing cap cannot be replaced as a single parts, because it is machined together with cylinder block.

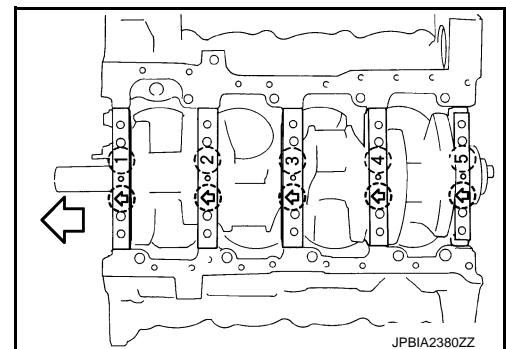

8. Install each main bearing cap bolts as per the following:

CAUTION:

If main bearing cap bolts and sub bolts are re-used, check their outer diameters before installation. Refer to [EM-265, "Inspection"](#).

CYLINDER BLOCK

[VK50VE]

< UNIT DISASSEMBLY AND ASSEMBLY >

- Apply new engine oil to threads and seat surfaces of main bearing cap bolts and sub bolts.
- Tighten all bolts in order of (No. 1 - 30) temporarily.

↶ : Engine front

- Tighten main bearing cap bolts (M12) in order of No. 1 - 10.

: **53.9 N-m (5.5 kg-m, 40 ft-lb)**

- Tighten main bearing cap sub bolts (M9) in order of No. 11 - 20.

: **19.6 N-m (2.0 kg-m, 14 ft-lb)**

- Tighten main bearing cap bolts (M12) in order of No. 1 - 10 (clockwise).

Angle tightening: 90 degrees

CAUTION:

Use the angle wrench [SST: KV10112100 (BT8653-A)] (A) to check tightening angle. Never make judgment by visual inspection.

- Tighten main bearing cap sub bolts (M9) in order of No. 11 - 20 (clockwise).

Angle tightening: 90 degrees

- Tighten side bolts (M10) in order of No. 21 - 30.

: **49.0 N-m (5.0 kg-m, 36 ft-lb)**

- After installing bolts, check that crankshaft can be rotated smoothly by hand.
- Check the crankshaft end play. Refer to [EM-287. "Cylinder Block"](#).

- Install rear oil seal retainer.

- Apply a continuous bead of liquid gasket with tube presser (commercial service tool) to rear oil seal retainer as shown in the figure.

A : Protrusion

b : 4.0 - 5.6 mm (0.157 - 0.220 in)

c : $\phi 3.4 - 4.4$ mm (0.134 - 0.173 in)

Use Genuine RTV Silicone Sealant or an equivalent. Refer to [GI-15. "Recommended Chemical Products and Sealants"](#).

- Install rear oil seal on rear oil seal retainer.

↶ : Engine inside

↔ : Engine outside

- Apply new engine oil to both oil seal lip (A) and dust seal lip (B).
- Install it so that each seal lip is oriented as shown in the figure.

CAUTION:

Be careful not to scratch or make burrs on circumference of oil seal.

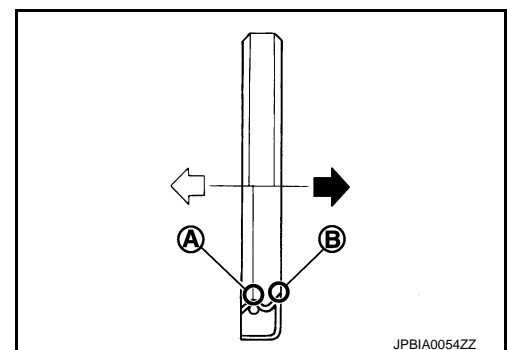
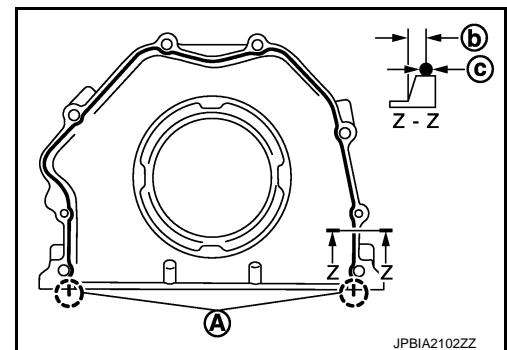
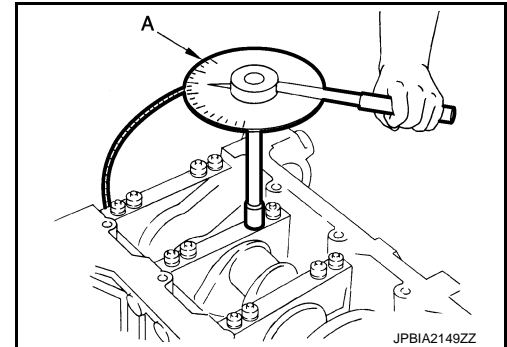
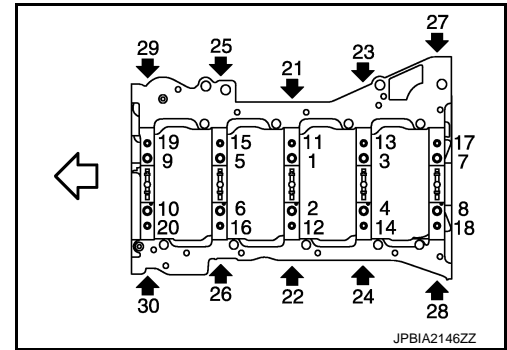

A

EM

C

D

E

F

G

H

I

J

K

L

M

N

O

P

CYLINDER BLOCK

< UNIT DISASSEMBLY AND ASSEMBLY >

[VK50VE]

- Press in rear oil seal (1) to the position as shown in the figure.

B : Rear oil seal retainer rear end face

a : 0 - 0.5 mm (0 - 0.020 in)

- Using a suitable drift [outer diameter: 101 mm (3.98 in)].
- Check the garter spring is in position and seal lips are not inverted.

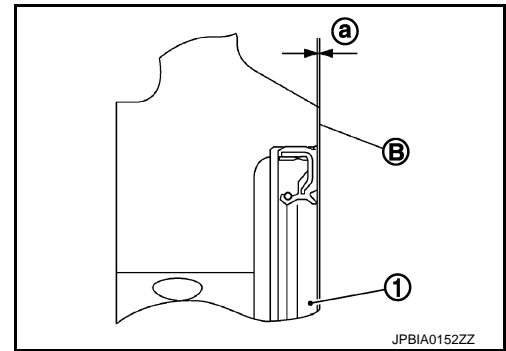

11. Install piston to connecting rod as per the following:

- Assemble so that the front mark (A) on the piston head and the cylinder number (D) on connecting rod are positioned as shown in the figure.

B : Oil hole

C : Front mark

↔ : Engine front

- a. Using snap ring pliers, install new snap ring to the groove of piston rear side.

- Insert it fully into groove to install.

- b. Install piston to connecting rod.

- Using an industrial use dryer or similar tool, heat piston until piston pin can be pushed in by hand without excess force [approximately 60 to 70°C (140 to 158°F)]. From the front to the rear, insert piston pin into piston and connecting rod.

- c. Install new snap ring to the groove of the piston front side.

- Insert it fully into groove to install.
- After installing, check that connecting rod moves smoothly.

12. Using a piston ring expander (commercial service tool) (A), install piston rings.

CAUTION:

- **When installing piston rings, be careful not to damage piston.**
- **Be careful not to damage piston rings by expanding them excessively.**

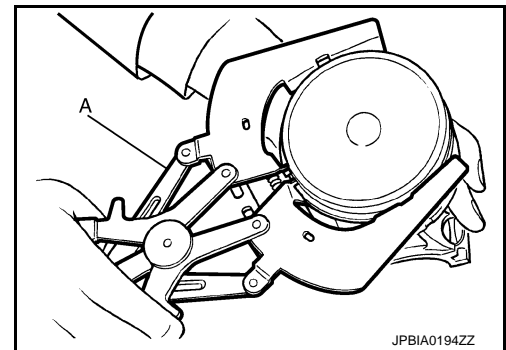
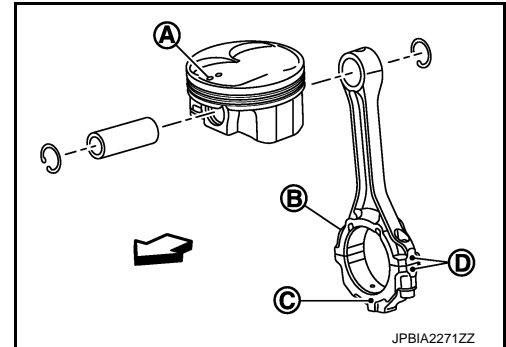

- If there is stamped mark on ring, mount it with marked side up.

Stamped mark:

Top ring (A) : 1 N

Second ring (B) : 2 N

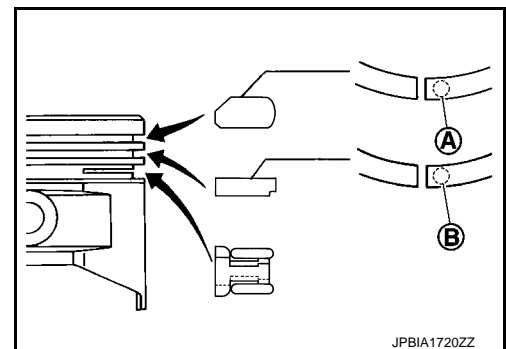

CYLINDER BLOCK

< UNIT DISASSEMBLY AND ASSEMBLY >

[VK50VE]

- Position each ring with the gap as shown in the figure referring to the piston front mark (D).

- a : 90 degrees
- b : 45 degrees
- C : Top ring gap
- E : Oil ring upper or lower rail gap (either of them)
- F : Second ring and oil ring spacer gap

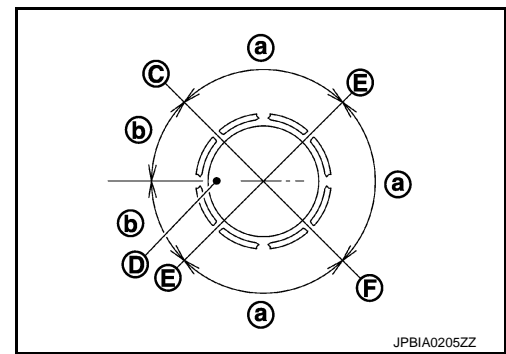

- Check the piston ring side clearance. Refer to [EM-265. "Inspection"](#).

13. Install connecting rod bearings to connecting rod and connecting rod bearing cap.

CAUTION:

Be careful not to drop connecting rod bearing, and to scratch the surface.

- Before installing connecting rod bearings, apply engine oil to the bearing surface (inside). Do not apply engine oil to the back surface, but thoroughly clean it.
- When installing, align connecting rod bearing stopper protrusion (B) with cutout (A) of connecting rods and connecting rod bearing caps to install.
- Ensure the oil hole (C) on connecting rod and that on the corresponding bearing are aligned.

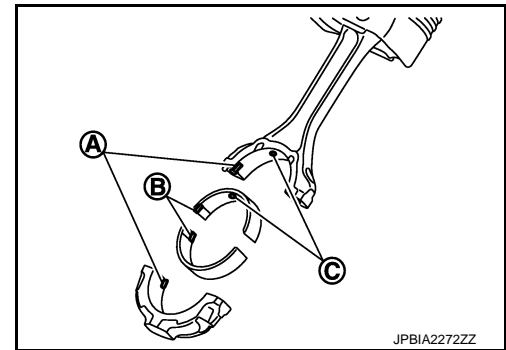

14. Install piston and connecting rod assembly to crankshaft.

- Position crankshaft pin corresponding to connecting rod to be installed onto the bottom dead center.
- Apply engine oil sufficiently to the cylinder bore, piston and crankshaft pin journal.
- Match the cylinder position with the cylinder number on connecting rod to install.
- Be sure that front mark on piston crown is facing the front of the engine.
- Using a piston ring compressor [SST: EM03470000 (J-8037)] (A) or suitable tool, install piston with the front mark on the piston crown facing the front of the engine.

CAUTION:

Be careful not to damage the cylinder wall and crankshaft pin, resulting from an interference of the connecting rod big end.

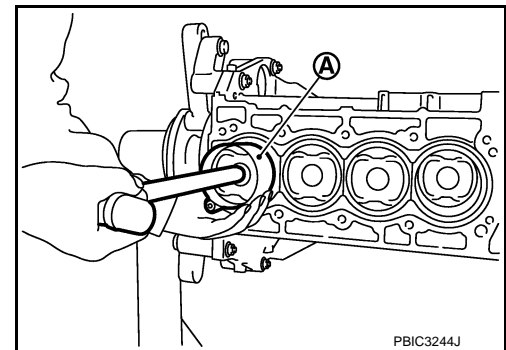

15. Install connecting rod bearing cap.

- Match the stamped cylinder number marks on connecting rod with those on connecting rod bearing cap to install.

- A : Sample codes
- B : Bearing stopper groove
- C : Small-end diameter grade
- D : Big-end diameter grade
- E : Weight grade
- F : Cylinder No.
- G : Management code

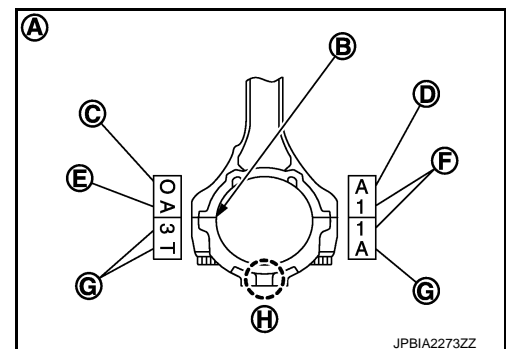

CYLINDER BLOCK

[VK50VE]

< UNIT DISASSEMBLY AND ASSEMBLY >

- Be sure that front mark (H) on connecting rod bearing cap is facing the front of the engine.

16. Tighten connecting rod bolts as per the following:

- Inspect the outer diameter of connecting rod bolt. Refer to [EM-265, "Inspection"](#).
- Apply engine oil to the threads and seats of connecting rod bolts.
- Tighten connecting rod bolts.

: 28.4 N·m (2.9 kg-m, 21 ft-lb)

d. Completely loosen connecting rod bolts.

: 0 N·m (0 kg-m, 0 ft-lb)

e. Tighten connecting rod bolts.

: 24.5 N·m (2.5 kg-m, 18 ft-lb)

f. Tighten connecting rod bolts. (clockwise)

Angle tightening: 90 degrees

CAUTION:

Always use the angle wrench [SST: KV10112100 (BT8653-A)]. Never make judgment by visual inspection.

- After tightening connecting rod bolts, check that crankshaft rotates smoothly.
- Check the connecting rod side clearance. Refer to [EM-265, "Inspection"](#).

17. Install knock sensors.

- Install knock sensors in the direction shown in the figure.

 : Engine front

- After installing knock sensor, connect harness connector, and lay it out to front of the engine.

CAUTION:

- **Never tighten mounting bolts while holding connector.**
- **If any impact by dropping is applied to knock sensor, replace it with new one.**

NOTE:

- Check that there is no foreign material on the cylinder block mating surface and the back surface of knock sensor.
- Check that knock sensor does not interfere with other parts.

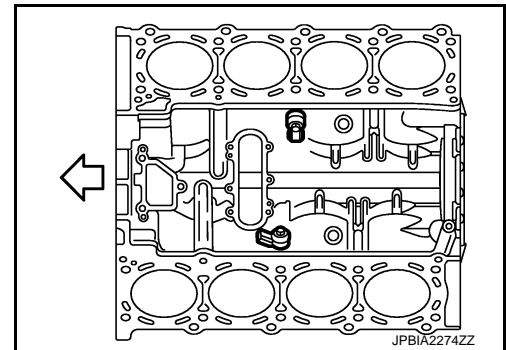

18. Install oil filter (for VVEL ladder assembly).

19. Install drive plate.

- Install drive plate (4) and reinforcement plate (3) as shown in the figure.

2 : Pilot converter

A : Rounded

 : Engine front

- When installing drive plate to crankshaft (1), be sure to correctly align crankshaft side dowel pin and drive plate side dowel pin hole.

CAUTION:

If these are not aligned correctly, engine runs roughly and "MIL" illuminates.

- Holding ring gear with the ring gear stopper [SST: KV10119200 (J-49277)].
- Tighten the mounting bolts crosswise over several times.

20. Assemble in the reverse order of disassembly.

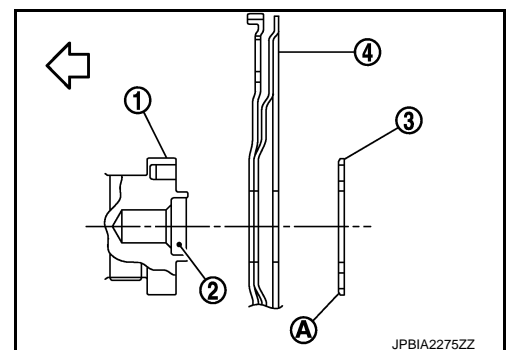

CYLINDER BLOCK

< UNIT DISASSEMBLY AND ASSEMBLY >

[VK50VE]

INFOID:000000003733458

Inspection

CRANKSHAFT END PLAY

- Measure the clearance between thrust bearings and crankshaft arm when crankshaft is moved fully forward or backward with a dial indicator (A).

Standard and limit : Refer to [EM-287, "Cylinder Block"](#).

- If the measured value exceeds the limit, replace thrust bearings, and measure again. If it still exceeds the limit, replace crankshaft also.

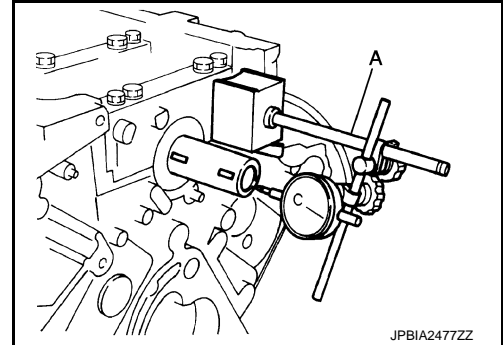

CONNECTING ROD SIDE CLEARANCE

- Measure the side clearance between connecting rod and crankshaft arm with a feeler gauge (A).

Standard and limit : Refer to [EM-287, "Cylinder Block"](#).

- If the measured value exceeds the limit, replace connecting rod, and measure again. If it still exceeds the limit, replace crankshaft also.

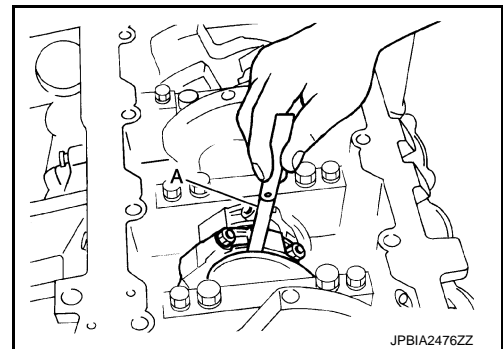

PISTON TO PISTON PIN OIL CLEARANCE

Piston Pin Hole Diameter

Measure the inner diameter of piston pin hole with an inside micrometer (A).

Standard : Refer to [EM-287, "Cylinder Block"](#).

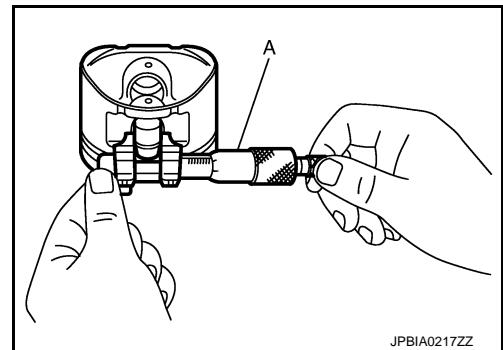

Piston Pin Outer Diameter

Measure the outer diameter of piston pin with a micrometer (A).

Standard : Refer to [EM-287, "Cylinder Block"](#).

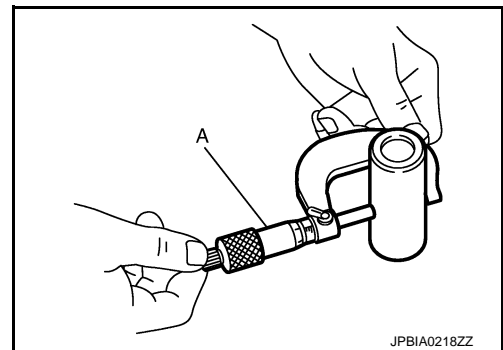

Piston to Piston Pin Oil Clearance

(Piston to piston pin oil clearance) = (Piston pin hole diameter) – (Piston pin outer diameter)

Standard : Refer to [EM-287, "Cylinder Block"](#).

A
EM
C
D
E
F
G
H
I
J
K
L
M
N
O
P

CYLINDER BLOCK

[VK50VE]

< UNIT DISASSEMBLY AND ASSEMBLY >

- If the calculated value is out of the standard, replace piston and piston pin assembly.
- When replacing piston and piston pin assembly, refer to [EM-274, "Description"](#).

NOTE:

Piston is available together with piston pin as assembly.

PISTON RING SIDE CLEARANCE

- Measure the side clearance of piston ring (1) and piston ring groove with a feeler gauge (C).

A : OK

B : NG

Standard and limit : Refer to [EM-287, "Cylinder Block"](#).

- If the measured value exceeds the limit, replace piston ring, and measure again. If it still exceeds the limit, replace piston also.

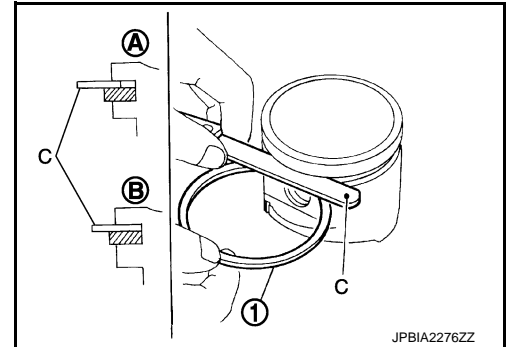

PISTON RING END GAP

- Check that the cylinder bore inner diameter is within the specification.
- Lubricate with new engine oil to piston (1) and piston ring (2), and then insert piston ring until middle of cylinder with piston, and measure the piston ring end gap with a feeler gauge (B).

A : Press-fit

Standard and limit : Refer to [EM-287, "Cylinder Block"](#).

- If the measured value exceeds the limit, replace piston ring, and measure again. If it still exceeds the limit, re-bore cylinder and use oversize piston and piston rings.

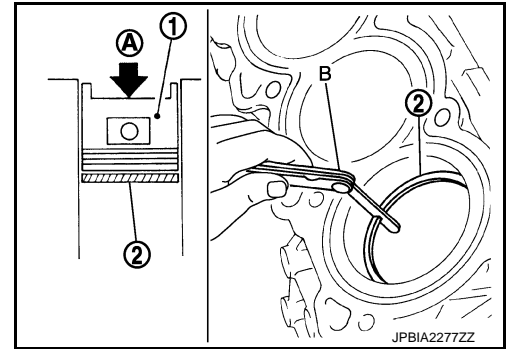

CONNECTING ROD BEND AND TORSION

- Check with a connecting rod aligner.

A : Bend

B : Torsion

C : Feeler gauge

Bend limit : Refer to [EM-287,](#)

Torsion limit ["Cylinder Block"](#).

- If it exceeds the limit, replace connecting rod assembly.

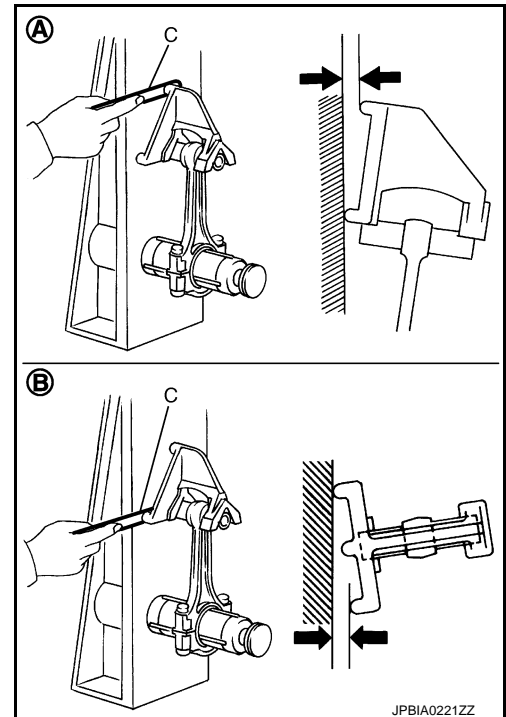

CONNECTING ROD BIG END DIAMETER

CYLINDER BLOCK

[VK50VE]

< UNIT DISASSEMBLY AND ASSEMBLY >

- Install connecting rod bearing cap without installing connecting rod bearing, and tighten connecting rod bolts to the specified torque. Refer to [EM-256, "Disassembly and Assembly"](#) for the tightening procedure.

1 : Connecting rod

- Measure the inner diameter of connecting rod big end with an inside micrometer.

Standard : Refer to [EM-287, "Cylinder Block"](#).

- If out of the standard, replace connecting rod assembly.

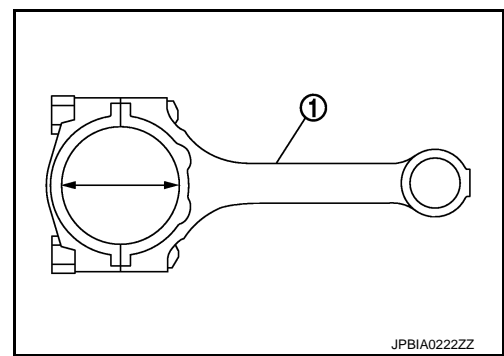

CONNECTING ROD BUSHING OIL CLEARANCE

Connecting Rod Bushing Inner Diameter

Measure the inner diameter of connecting rod bushing with an inside micrometer (A).

Standard : Refer to [EM-287, "Cylinder Block"](#).

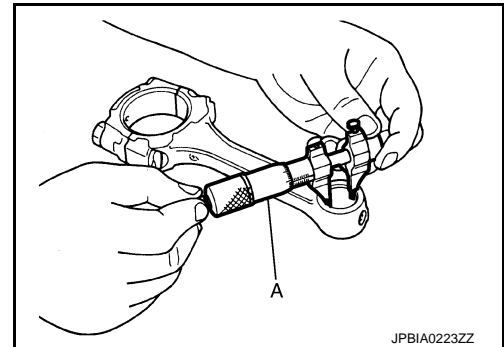

Piston Pin Outer Diameter

Measure the outer diameter of piston pin with a micrometer (A).

Standard : Refer to [EM-287, "Cylinder Block"](#).

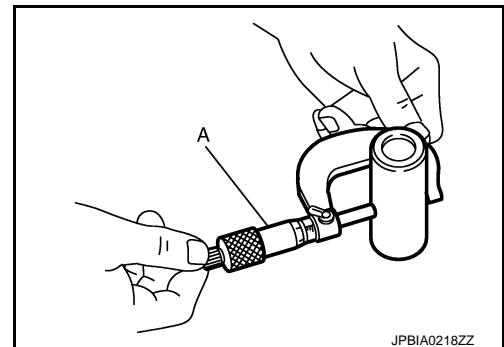

Connecting Rod Bushing Oil Clearance

(Connecting rod bushing oil clearance) = (Connecting rod bushing inner diameter) – (Piston pin outer diameter)

Standard and limit : Refer to [EM-287, "Cylinder Block"](#).

- If the calculated value exceeds the limit, replace connecting rod assembly and/or piston and piston pin assembly.
- If replacing piston and piston pin assembly, refer to [EM-274, "Description"](#).
- If replacing connecting rod assembly, refer to [EM-275, "Connecting Rod Bearing"](#) to select the connecting rod bearing.

CYLINDER BLOCK DISTORTION

- Using a scraper, remove gasket on the cylinder block surface, and also remove engine oil, scale, carbon, or other contamination.

CAUTION:

Be careful not to allow gasket flakes to enter engine oil or engine coolant passages.

CYLINDER BLOCK

[VK50VE]

< UNIT DISASSEMBLY AND ASSEMBLY >

- Measure the distortion on the cylinder block upper face at some different points in six directions (C, D, E, F, G and H) with a straightedge (A) and a feeler gauge (B).

Limit : Refer to [EM-287, "Cylinder Block"](#).

- If it exceeds the limit, replace cylinder block.

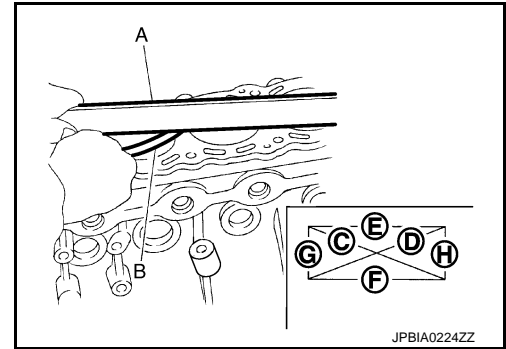

MAIN BEARING HOUSING INNER DIAMETER

- Install main bearing cap (2) without installing main bearings, and tighten main bearing cap bolts to the specified torque. Refer to [EM-256, "Disassembly and Assembly"](#) for the tightening procedure.
- Measure the inner diameter of main bearing housing with a bore gauge.

Standard : Refer to [EM-287, "Cylinder Block"](#).

- If out of the standard, replace cylinder block (1) and main bearing cap as assembly.

NOTE:

Cylinder block cannot be replaced as a single part, because it is machined together with main bearing cap.

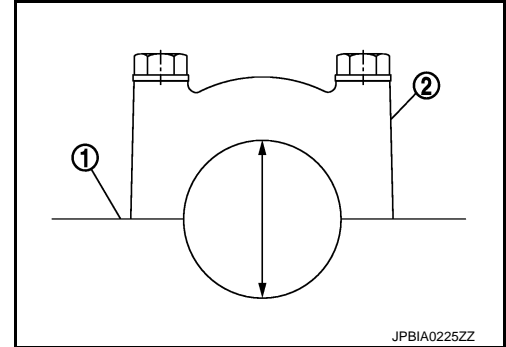

PISTON TO CYLINDER BORE CLEARANCE

Cylinder Bore inner Diameter

- Using a bore gauge, measure cylinder bore for wear, out-of-round and taper at six different points on each cylinder. [(A) and (B) directions at (C), (D) and (E)] is in longitudinal direction of engine.

f : 10 mm (0.39 in)

g : 60 mm (2.36 in)

h : 120 mm (4.72 in)

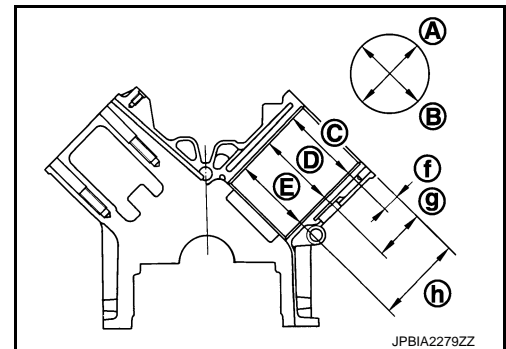

Wear limit:

Out-of-round (Difference between "A" and "B"):

Refer to [EM-287, "Cylinder Block"](#).

Taper limit (Difference between "C" and "E"):

- If the measured value exceeds the limit, or if there are scratches and/or seizure on the cylinder inner wall, hone or re-bore the inner wall.
- Oversize piston is provided. When using oversize piston, re-bore cylinder so that the clearance of the piston-to-cylinder bore satisfies the standard.

CAUTION:

When using oversize piston, use oversize pistons for all cylinders with oversize piston rings.

Oversize (O/S) : 0.2 mm (0.008 in)

Piston Skirt Diameter

CYLINDER BLOCK

< UNIT DISASSEMBLY AND ASSEMBLY >

[VK50VE]

Measure the outer diameter of piston skirt with a micrometer (A).

Measure point
Standard : Refer to [EM-287, "Cylinder Block"](#).

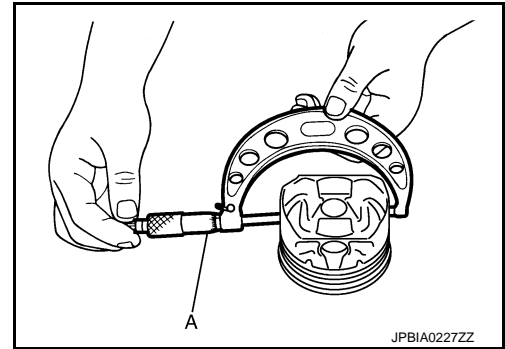

Piston-to-Cylinder Bore Clearance

Calculate by piston skirt diameter and cylinder bore inner diameter [direction (B), position (D)].

(Clearance) = (Cylinder bore inner diameter) – (Piston skirt diameter).

Standard and limit : Refer to [EM-287, "Cylinder Block"](#).

- If the calculated value exceeds the limit, replace piston and piston pin assembly. Refer to [EM-287, "Cylinder Block"](#).

Re-boring Cylinder Bore

1. Cylinder bore size is determined by adding piston to cylinder bore clearance to piston skirt diameter.

Re-bored size calculation: $D = A + B - C$

where,

A: Piston skirt diameter as measured

B: Piston to cylinder bore clearance (standard value)

C: Honing allowance 0.02 mm (0.0008 in)

D: Bored diameter

2. Install main bearing cap, and tighten to the specified torque. Otherwise, cylinder bores may be distorted in final assembly.
3. Cut cylinder bores.
NOTE:
 - When any cylinder needs boring, all other cylinders must also be bored.
 - Do not cut too much out of cylinder bore at a time. Cut only 0.05 mm (0.0020 in) or so in diameter at a time.
- 4.hone cylinders to obtain the specified piston to cylinder bore clearance.
5. Measure finished cylinder bore for the out-of-round and taper.

NOTE:

Perform measurement after cylinder bore cools down.

CRANKSHAFT MAIN JOURNAL DIAMETER

- Measure the outer diameter of crankshaft main journals with a micrometer.

Standard : Refer to [EM-287, "Cylinder Block"](#).

- If out of the standard, measure the main bearing oil clearance. Then use undersize bearing. Refer to [EM-277, "Main Bearing"](#).

CRANKSHAFT PIN JOURNAL DIAMETER

CYLINDER BLOCK

[VK50VE]

< UNIT DISASSEMBLY AND ASSEMBLY >

- Measure the outer diameter of crankshaft pin journal with a micrometer (A).

Standard : Refer to [EM-287, "Cylinder Block"](#).

- If out of the standard, measure the connecting rod bearing oil clearance. Then use undersize bearing. Refer to [EM-275, "Connecting Rod Bearing"](#).

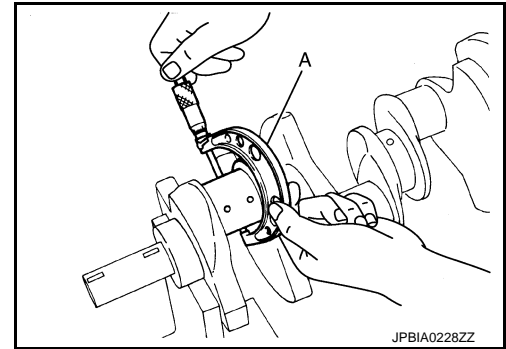

CRANKSHAFT OUT-OF-ROUND AND TAPER

- Measure the dimensions at four different points as shown in the figure on each main journal and pin journal with a micrometer.
- Out-of-round is indicated by the difference in the dimensions between (d) and (c) at (a) and (b).
- Taper is indicated by the difference in the dimensions between.

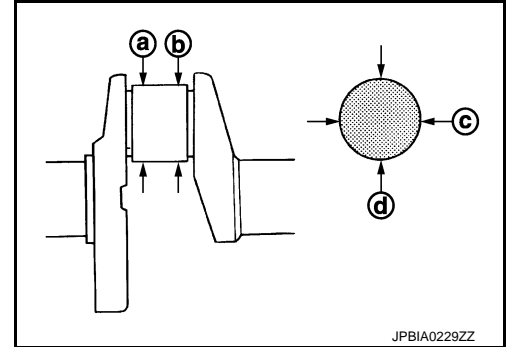

Out-of-round (Difference between "c" and "d")

Taper (Difference between "a" and "b")

: Refer to [EM-287, "Cylinder Block"](#).

- If the measured value exceeds the limit, correct or replace crankshaft.
- If corrected, measure the bearing oil clearance of the corrected main journal and/or pin journal. Then select the main bearing and/or connecting rod bearing. Refer to [EM-277, "Main Bearing"](#) and/or [EM-275, "Connecting Rod Bearing"](#).

CRANKSHAFT RUNOUT

- Place V-block on precise flat table, and support the journals on both ends of crankshaft.
- Place a dial indicator straight up on the No. 3 journal.
- While rotating crankshaft, read the movement of the pointer on a dial indicator. (Total indicator reading)

Standard and limit : Refer to [EM-287, "Cylinder Block"](#).

- If it exceeds the limit, replace crankshaft.

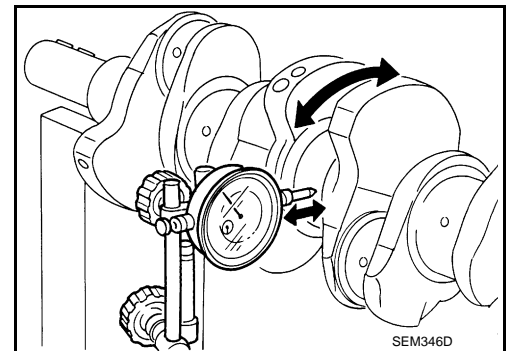

CONNECTING ROD BEARING OIL CLEARANCE

Method by Calculation

- Install connecting rod bearings (1) to connecting rod (2) and connecting rod cap, and tighten connecting rod bolts to the specified torque. Refer to [EM-256, "Disassembly and Assembly"](#) for the tightening procedure.

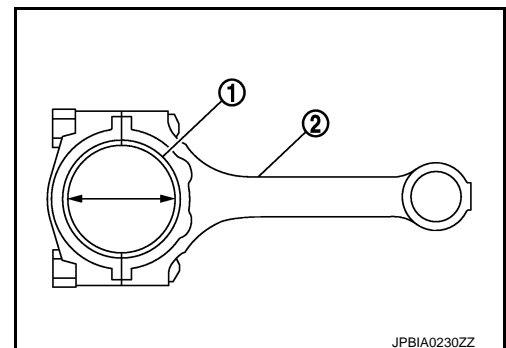

CYLINDER BLOCK

< UNIT DISASSEMBLY AND ASSEMBLY >

[VK50VE]

- Measure the inner diameter of connecting rod bearing with an inside micrometer.
(Oil clearance) = (Connecting rod bearing inner diameter) – (Crankshaft pin journal diameter)

Standard and limit : Refer to [EM-292, "Connecting Rod Bearing"](#).

- If the calculated value exceeds the limit, select proper connecting rod bearing according to connecting rod big end diameter and crankshaft pin journal diameter to obtain the specified bearing oil clearance. Refer to [EM-274, "Description"](#).

Method of Using Plastigage

- Remove oil and dust on crankshaft pin journal and the surfaces of each bearing completely.
- Cut a plastigage slightly shorter than the bearing width, and place it in crankshaft axial direction, avoiding oil holes.
- Install connecting rod bearings to connecting rod and connecting rod bearing cap, and tighten connecting rod bolts to the specified torque. Refer to [EM-256, "Disassembly and Assembly"](#) for the tightening procedure.

CAUTION:

Never rotate crankshaft.

- Remove connecting rod bearing cap and bearings, and using the scale on the plastigage bag, measure the plastigage width.

NOTE:

The procedure when the measured value exceeds the limit is the same as that described in the "Method by Calculation".

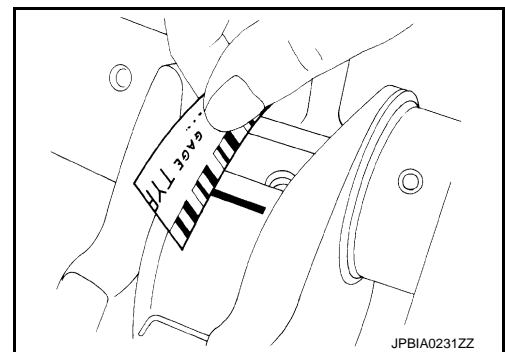

MAIN BEARING OIL CLEARANCE

Method by Calculation

- Install main bearings (3) to cylinder block (1) and main bearing cap (2), and tighten main bearing cap bolts to the specified torque. Refer to [EM-256, "Disassembly and Assembly"](#) for the tightening procedure.
- Measure the inner diameter of main bearing with a bore gauge.
(Oil clearance) = (Main bearing inner diameter) – (Crankshaft main journal diameter)

Standard and limit : Refer to [EM-291, "Main Bearing"](#).

- If the calculated value exceeds the limit, select proper main bearing according to main bearing inner diameter and crankshaft main journal diameter to obtain the specified bearing oil clearance. Refer to [EM-274, "Description"](#).

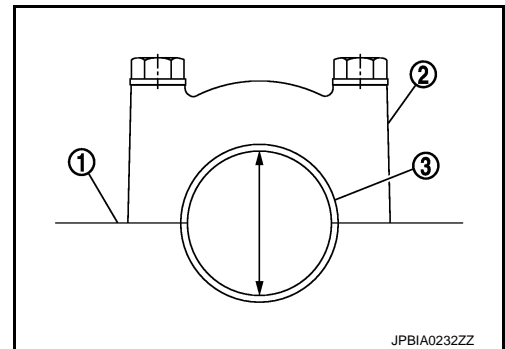

Method of Using Plastigage

- Remove engine oil and dust on crankshaft journal and the surfaces of each bearing completely.
- Cut a plastigage slightly shorter than the bearing width, and place it in crankshaft axial direction, avoiding oil holes.
- Install main bearing to cylinder block and main bearing cap, and tighten main bearing cap bolts with main bearing cap to the specified torque. Refer to [EM-256, "Disassembly and Assembly"](#) for the tightening procedure.

CAUTION:

Never rotate crankshaft.

A
EM
C
D
E
F
G
H
I
J
K
L
M
N
O
P

CYLINDER BLOCK

[VK50VE]

< UNIT DISASSEMBLY AND ASSEMBLY >

- Remove main bearing cap and bearings, and using the scale on the plastigage bag, measure the plastigage width.

NOTE:

The procedure when the measured value exceeds the limit is the same as that described in the "Method by Calculation".

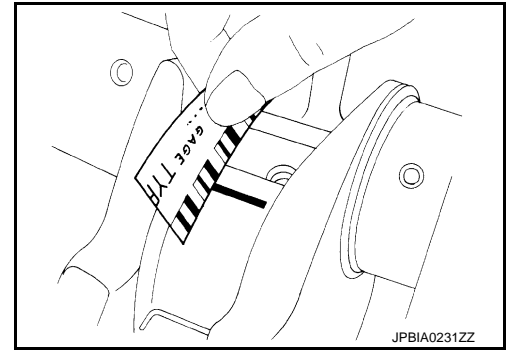

MAIN BEARING CRUSH HEIGHT

- When main bearing cap is removed after being tightened to the specified torque with main bearings (1) installed, the tip end of bearing must protrude. Refer to [EM-256, "Disassembly and Assembly"](#) for the tightening procedure.

A : Crush height

Standard : There must be crush height.

- If the standard is not met, replace main bearings.

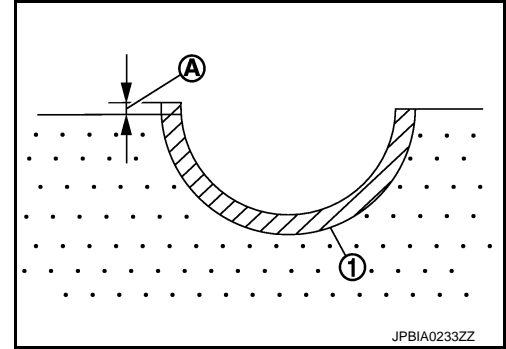

CONNECTING ROD BEARING CRUSH HEIGHT

- When connecting rod bearing cap is removed after being tightened to the specified torque with connecting rod bearings (1) installed, the tip end of bearing must protrude. Refer to [EM-256, "Disassembly and Assembly"](#) for the tightening procedure.

A : Crush height

Standard : There must be crush height.

- If the standard is not met, replace connecting rod bearings.

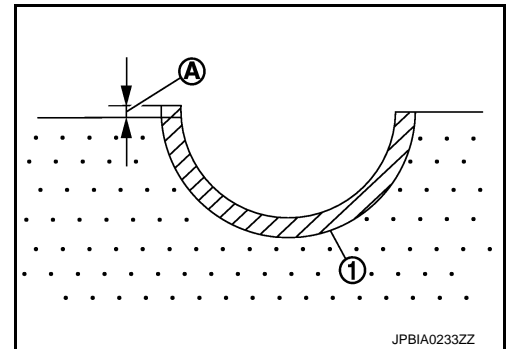

MAIN BEARING CAP BOLT OUTER DIAMETER

- Measure the outer diameters (A), (B) at two positions as shown in the figure.

c : 20 mm (0.79 in)

d : 40 mm (1.57 in)

e : 12 mm (0.47 in)

- If reduction appears in (A) range, regard it (B).

Limit [(B) – (A)] : 0.18 mm (0.0071 in)

- If it exceeds the limit (large difference in dimensions), replace main bearing cap bolts with new one.

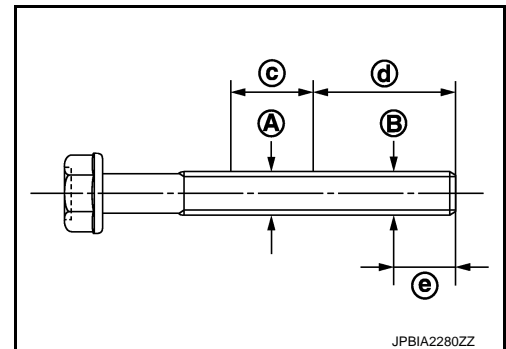

MAIN BEARING CAP SUB BOLT OUTER DIAMETER

CYLINDER BLOCK

[VK50VE]

< UNIT DISASSEMBLY AND ASSEMBLY >

- Measure the outer diameters (A), (B) at two positions as shown in the figure.

c : 20 mm (0.79 in)
 d : 50 mm (1.97 in)
 e : 9 mm (0.35 in)

- If reduction appears in (A) range, regard it (B).

Limit [(B) – (A)] : 0.13 mm (0.0051 in)

- If it exceeds the limit (large difference in dimensions), replace main bearing cap sub bolts with new one.

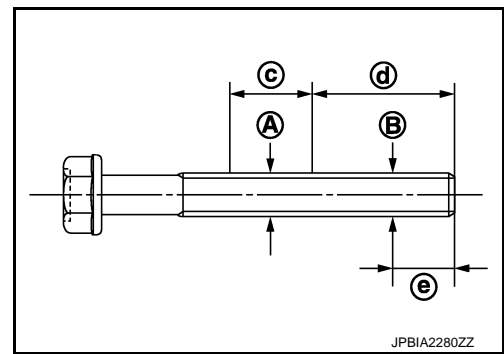

CONNECTING ROD BOLT OUTER DIAMETER

1. Measure the outer diameters [(a), (b) and (c)] at the position shown in the figure.

a : Value at the end of the smaller diameter of the bolt
 b : Value at the end of the smaller diameter of the bolt [opposite side of (a)]
 c : Value of the smallest diameter of the smaller of the bolt

2. Obtain a mean value (d) of (a) and (b).
3. Subtract (c) from (d).

Limit [(d) – (c)] : 0.09 mm (0.0035 in)

4. If it exceeds the limit (large difference in dimensions), replace the bolt with new one.

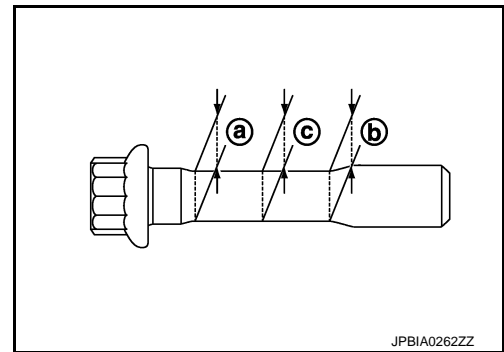

DRIVE PLATE

- Check drive plate and signal plate (A) for deformation or damage.

B : Ring gear
 ← : Engine front

CAUTION:

- Never disassemble drive plate.
- Never place drive plate with signal plate facing down.
- When handling signal plate, take care not to damage or scratch it.
- Handle signal plate in a manner that prevents it from becoming magnetized.
- If damage is found, replace drive plate.

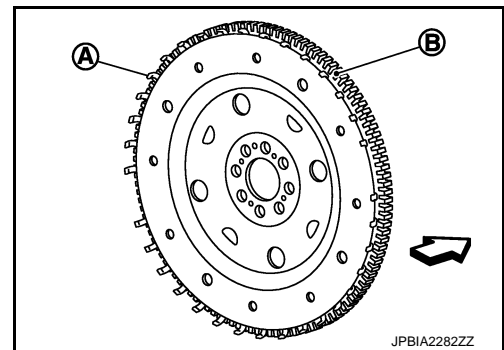

OIL JET

- Check nozzle for deformation and damage.
- Blow compressed air from nozzle, and check for clogs.
- Using a clean plastic stick, press check valve in oil jet relief valve. Check that valve moves smoothly with proper reaction force.
- If it is not satisfied, clean or replace oil jet.

HOW TO SELECT PISTON AND BEARING

< UNIT DISASSEMBLY AND ASSEMBLY >

[VK50VE]

HOW TO SELECT PISTON AND BEARING

Description

INFOID:000000003733459

Selection points	Selection parts	Selection items	Selection methods
Between cylinder block and crankshaft	Main bearing	Main bearing grade (bearing thickness)	Determined by match of cylinder block bearing housing grade (inner diameter of housing) and crankshaft journal grade (outer diameter of journal)
Between crankshaft and connecting rod	Connecting rod bearing	Connecting rod bearing grade (bearing thickness)	Determined by match of connecting rod big end diameter grade (inner diameter of housing) and crankshaft pin outer diameter.
Between cylinder block and piston	Piston and piston pin assembly (Piston is available together with piston pin as assembly.)	Piston grade (piston skirt diameter)	Piston grade = cylinder bore grade (inner diameter of bore)

- The identification grade stamped on each part is the grade for the dimension measured in new condition. This grade cannot apply to reused parts.
- For reused or repaired parts, measure the dimension accurately. Determine the grade by comparing the measurement with the values of each selection table.
- For details of the measurement method of each part, the reuse standards and the selection method of the selective fitting parts, refer to the text.

Piston

INFOID:000000003733460

WHEN NEW CYLINDER BLOCK IS USED

Check the cylinder bore grade ("1", "2" or "3") on rear side of cylinder block, and select piston of the same grade.

- A : Bearing housing grade No. 1
 - B : Bearing housing grade No. 2
 - C : Bearing housing grade No. 3
 - D : Bearing housing grade No. 4
 - E : Bearing housing grade No. 5
 - F : Cylinder bore grade No. 1
 - G : Cylinder bore grade No. 2
 - H : Cylinder bore grade No. 3
 - I : Cylinder bore grade No. 4
 - J : Cylinder bore grade No. 5
 - K : Cylinder bore grade No. 6
 - L : Cylinder bore grade No. 7
 - M : Cylinder bore grade No. 8
- ⇐ : Engine front

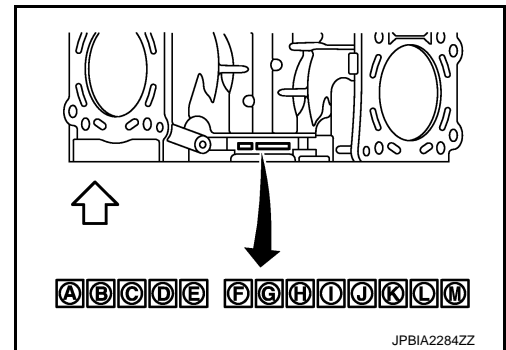

NOTE:

Piston is available with piston pin as a set for the service part.

WHEN NEW CYLINDER BLOCK IS REUSED

1. Measure the cylinder bore inner diameter. Refer to [EM-287, "Cylinder Block"](#).

HOW TO SELECT PISTON AND BEARING

< UNIT DISASSEMBLY AND ASSEMBLY >

[VK50VE]

- Determine the bore grade by comparing the measurement with the values under the cylinder bore inner diameter of the "PISTON SELECTION TABLE".

- A : Bank 2
- B : Bank 1
- C : Front mark
- D : Piston grade number
- E : Piston pin grade number
- F : Identification code

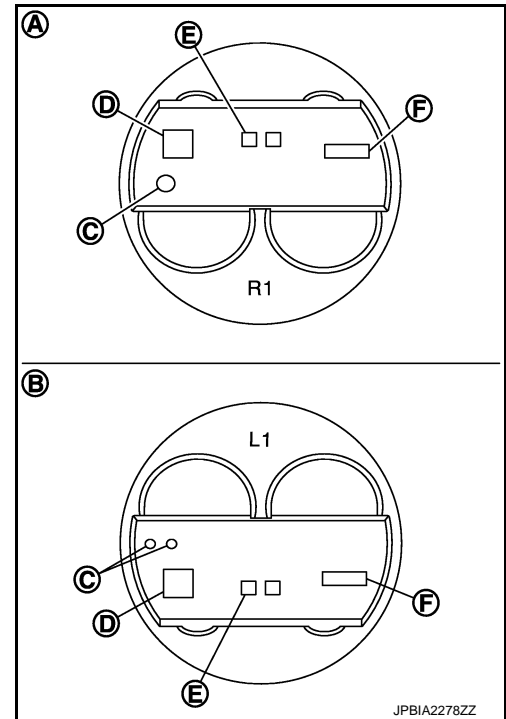

- Select piston of the same grade.

PISTON SELECTION TABLE

Unit: mm (in)

Grade	1	2	3
Cylinder bore inner diameter	95.500 - 95.510 (3.7598 - 3.7602)	95.510 - 95.520 (3.7602 - 3.7606)	95.520 - 95.530 (3.7606 - 3.7610)
Piston skirt diameter	95.480 - 95.490 (3.7590 - 3.7594)	95.490 - 95.500 (3.7594 - 3.7598)	95.500 - 95.510 (3.7598 - 3.7602)

NOTE:

Piston is available together with piston pin as assembly.

Connecting Rod Bearing

INFOID:000000003733461

WHEN NEW CONNECTING ROD AND CRANKSHAFT ARE USED

- Apply connecting rod big end diameter grade stamped (D) on connecting rod side face to the row in the "CONNECTING ROD BEARING SELECTION TABLE".

- A : Sample codes
- B : Bearing stopper groove
- C : Small-end diameter grade
- E : Weight grade
- F : Cylinder No.
- G : Management code
- H : Front mark

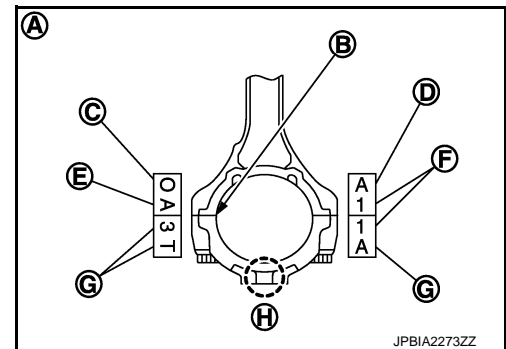

HOW TO SELECT PISTON AND BEARING

< UNIT DISASSEMBLY AND ASSEMBLY >

[VK50VE]

- Apply crankshaft pin journal diameter grade stamped on crankshaft front side to the column in the "CONNECTING ROD BEARING SELECTION TABLE"

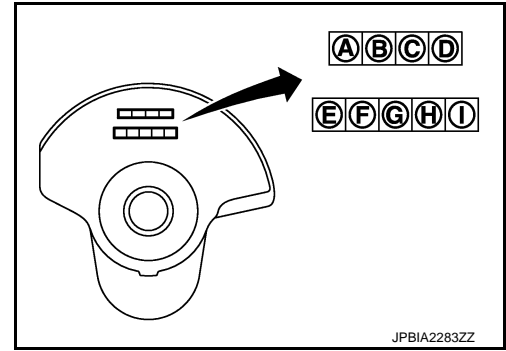

- A : Pin diameter grade No. 1
- B : Pin diameter grade No. 2
- C : Pin diameter grade No. 3
- D : Pin diameter grade No. 4
- E : Journal diameter grade No. 1
- F : Journal diameter grade No. 2
- G : Journal diameter grade No. 3
- H : Journal diameter grade No. 4
- I : Journal diameter grade No. 5

- Read the symbol at the cross point of selected row and column in the "CONNECTING ROD BEARING SELECTION TABLE".
- Apply the symbol obtained to the "CONNECTING ROD BEARING GRADE TABLE" to select connecting rod bearing.

WHEN CONNECTING ROD AND CRANKSHAFT ARE REUSED

- Measure connecting rod big end diameter and crankshaft pin journal diameter. Refer to [EM-265. "Inspection"](#).
- Correspond the measured dimension in connecting rod big end diameter row of "CONNECTING ROD BEARING SELECTION TABLE".
- Correspond the measured dimension in crankshaft pin journal diameter column of "CONNECTING ROD BEARING SELECTION TABLE".
- Follow from step 3 in "WHEN NEW CONNECTING ROD AND CRANKSHAFT ARE USED".

CONNECTING ROD BEARING SELECTION TABLE

Mark	Axle diameter	Connecting rod big end diameter Unit: mm (in)		Crankshaft pin journal diameter Unit: mm (in)													
		Hole diameter		Hole diameter													
				A	B	C	D	E	F	G	H	J	K	L	M	N	
A	53.974 - 53.973 (2.1250 - 2.1249)	57.000 - 57.001 (2.2441 - 2.2441)	57.001 - 57.002 (2.2441 - 2.2442)	0	0	0	0	0	0	0	1	1	1	1	1	2	
B	53.973 - 53.972 (2.1249 - 2.1249)	57.001 - 57.002 (2.2441 - 2.2442)	57.002 - 57.003 (2.2442 - 2.2442)	0	0	0	0	0	0	1	1	1	1	1	1	2	
C	53.972 - 53.971 (2.1249 - 2.1248)	57.002 - 57.003 (2.2442 - 2.2442)	57.003 - 57.004 (2.2442 - 2.2442)	0	0	0	0	1	1	1	1	1	1	1	2	2	
D	53.971 - 53.970 (2.1248 - 2.1248)	57.003 - 57.004 (2.2442 - 2.2442)	57.004 - 57.005 (2.2442 - 2.2443)	0	0	1	1	1	1	1	1	1	2	2	2	2	
E	53.970 - 53.969 (2.1248 - 2.1248)	57.004 - 57.005 (2.2442 - 2.2443)	57.005 - 57.006 (2.2443 - 2.2443)	0	1	1	1	1	1	1	2	2	2	2	2	2	
F	53.969 - 53.968 (2.1248 - 2.1247)	57.005 - 57.006 (2.2443 - 2.2443)	57.006 - 57.007 (2.2443 - 2.2444)	1	1	1	1	1	1	2	2	2	2	2	2	3	
G	53.968 - 53.967 (2.1247 - 2.1247)	57.006 - 57.007 (2.2443 - 2.2444)	57.007 - 57.008 (2.2444 - 2.2444)	1	1	1	1	1	2	2	2	2	2	2	3	3	
H	53.967 - 53.966 (2.1247 - 2.1246)	57.007 - 57.008 (2.2444 - 2.2444)	57.008 - 57.009 (2.2444 - 2.2444)	1	1	1	1	2	2	2	2	2	2	3	3	3	
J	53.966 - 53.965 (2.1246 - 2.1246)	57.008 - 57.009 (2.2444 - 2.2444)	57.009 - 57.010 (2.2444 - 2.2445)	1	1	1	2	2	2	2	2	2	3	3	3	3	
K	53.965 - 53.964 (2.1246 - 2.1246)	57.009 - 57.010 (2.2444 - 2.2445)	57.010 - 57.011 (2.2445 - 2.2445)	1	1	2	2	2	2	2	2	3	3	3	3	3	
L	53.964 - 53.963 (2.1246 - 2.1245)	57.010 - 57.011 (2.2445 - 2.2445)	57.011 - 57.012 (2.2445 - 2.2446)	1	1	2	2	2	2	2	3	3	3	3	3	3	
M	53.963 - 53.962 (2.1245 - 2.1245)	57.011 - 57.012 (2.2445 - 2.2446)	57.012 - 57.013 (2.2446 - 2.2446)	1	2	2	2	2	2	2	3	3	3	3	3	3	
N	53.962 - 53.961 (2.1245 - 2.1244)	57.012 - 57.013 (2.2446 - 2.2446)		2	2	2	2	2	2	3	3	3	3	3	3	4	
P	53.961 - 53.960 (2.1244 - 2.1244)			2	2	2	2	2	3	3	3	3	3	3	4	4	
R	53.960 - 53.959 (2.1244 - 2.1244)			2	2	2	3	3	3	3	3	3	3	4	4	4	
S	53.959 - 53.958 (2.1244 - 2.1243)			2	2	3	3	3	3	3	3	3	4	4	4	4	
T	53.958 - 53.957 (2.1243 - 2.1243)			2	2	3	3	3	3	3	3	4	4	4	4	4	
U	53.957 - 53.956 (2.1243 - 2.1242)			2	3	3	3	3	3	3	4	4	4	4	4	4	

JPBIA2287GB

HOW TO SELECT PISTON AND BEARING

< UNIT DISASSEMBLY AND ASSEMBLY >

[VK50VE]

CONNECTING ROD BEARING GRADE TABLE

Connecting rod bearing grade table : Refer to [EM-292, "Connecting Rod Bearing"](#).

UNDERSIZE BEARING USAGE GUIDE

- When the specified connecting rod bearing oil clearance is not obtained with standard size connecting rod bearings, use undersize (US) bearings.
- When using undersize (US) bearing, measure the connecting rod bearing inner diameter with bearing installed, and grind crankshaft pin so that the connecting rod bearing oil clearance satisfies the standard.

CAUTION:

In grinding crankshaft pin to use undersize bearings, keep the fillet R (A) [1.5 - 1.7 mm (0.059 - 0.067 in)].

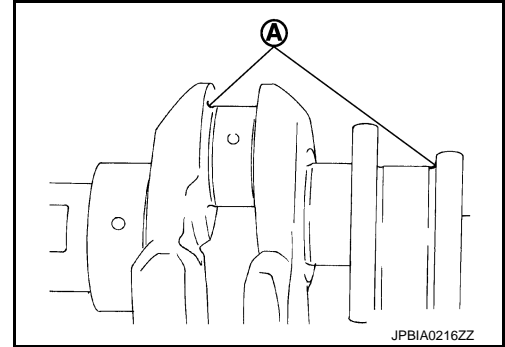

Bearing undersize table : Refer to [EM-292, "Connecting Rod Bearing"](#).

Main Bearing

INFOID:000000003733462

WHEN NEW CYLINDER BLOCK AND CRANKSHAFT ARE USED

1. "MAIN BEARING SELECTION TABLE" rows correspond to bearing housing grade on rear side of cylinder block.

- A : Bearing housing grade No. 1
- B : Bearing housing grade No. 2
- C : Bearing housing grade No. 3
- D : Bearing housing grade No. 4
- E : Bearing housing grade No. 5
- F : Cylinder bore grade No. 1
- G : Cylinder bore grade No. 2
- H : Cylinder bore grade No. 3
- I : Cylinder bore grade No. 4
- J : Cylinder bore grade No. 5
- K : Cylinder bore grade No. 6
- L : Cylinder bore grade No. 7
- M : Cylinder bore grade No. 8
- ⇐ : Engine front

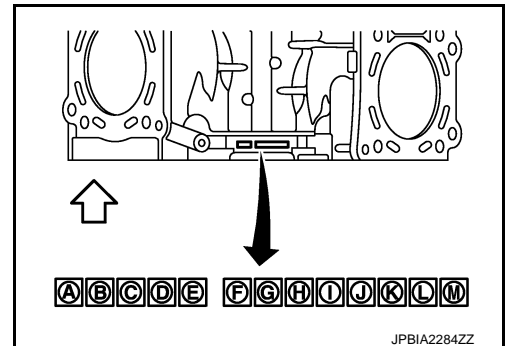

2. "MAIN BEARING SELECTION TABLE" columns correspond to journal diameter grade on front side of crankshaft.

- A : Pin diameter grade No. 1
- B : Pin diameter grade No. 2
- C : Pin diameter grade No. 3
- D : Pin diameter grade No. 4
- E : Journal diameter grade No. 1
- F : Journal diameter grade No. 2
- G : Journal diameter grade No. 3

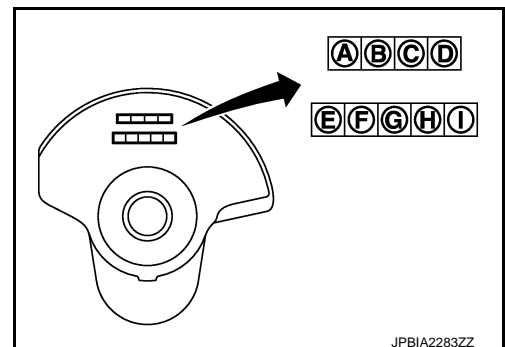

HOW TO SELECT PISTON AND BEARING

< UNIT DISASSEMBLY AND ASSEMBLY >

[VK50VE]

H : Journal diameter grade No. 4

I : Journal diameter grade No. 5

3. Select main bearing grade at the point where selected row and column meet in "MAIN BEARING SELECTION TABLE".

CAUTION:

- Initial clearance for No. 1, 5 journal and No. 2, 3, 4 journal is different. Use two different selection table for each part.
- No. 1, 5 journal and No. 2, 3, 4 journal have the same signs but different measures. Never confuse.

4. Apply sign at crossing in above step 3 to "MAIN BEARING GRADE TABLE".

NOTE:

- "MAIN BEARING GRADE TABLE" applies to all journals.
- Service parts are available as a set of both upper and lower.

WHEN CYLINDER BLOCK AND CRANKSHAFT ARE REUSED

1. Measure cylinder block main bearing housing inner diameter and crankshaft main journal diameter. Refer to [EM-265. "Inspection"](#).
2. Correspond the measured dimension in "Cylinder block main bearing housing inner diameter" row of "MAIN BEARING SELECTION TABLE".
3. Correspond the measured dimension in "Crankshaft main journal diameter" column of "MAIN BEARING SELECTION TABLE".
4. Follow from step 3 in "When New Cylinder Block and Crankshaft are Used".

HOW TO SELECT PISTON AND BEARING

< UNIT DISASSEMBLY AND ASSEMBLY >

[VK50VE]

MAIN BEARING SELECTION TABLE (No. 1 and 5 Journal)

I.D. mark	Cylinder block main bearing housing inner diameter	Crankshaft main journal diameter	Axle diameter Unit: mm (in)	I.D. mark	A	B	C	D	E	F	G	H	J	K	L	M	N	P	R	S	T	U	V	W	X	Y	4	7		
					Hole diameter Unit: mm (in)	68.944 - 68.945 (2.7143 - 2.7144)	68.945 - 68.946 (2.7144 - 2.7144)	68.946 - 68.947 (2.7144 - 2.7144)	68.947 - 68.948 (2.7144 - 2.7145)	68.948 - 68.949 (2.7145 - 2.7145)	68.949 - 68.950 (2.7145 - 2.7146)	68.950 - 68.951 (2.7146 - 2.7146)	68.951 - 68.952 (2.7146 - 2.7146)	68.952 - 68.953 (2.7146 - 2.7147)	68.953 - 68.954 (2.7147 - 2.7147)	68.954 - 68.955 (2.7147 - 2.7148)	68.955 - 68.956 (2.7148 - 2.7148)	68.956 - 68.957 (2.7148 - 2.7148)	68.957 - 68.958 (2.7148 - 2.7149)	68.958 - 68.959 (2.7149 - 2.7149)	68.959 - 68.960 (2.7149 - 2.7150)	68.960 - 68.961 (2.7150 - 2.7150)	68.961 - 68.962 (2.7150 - 2.7150)	68.962 - 68.963 (2.7150 - 2.7151)	68.963 - 68.964 (2.7151 - 2.7151)	68.964 - 68.965 (2.7151 - 2.7152)	68.965 - 68.966 (2.7152 - 2.7152)	68.966 - 68.967 (2.7152 - 2.7152)	68.967 - 68.968 (2.7152 - 2.7153)	
G	63.964 - 63.963 (2.5183 - 2.5182)	1	1	12	12	12	2	2	2	23	23	23	3	3	3	34	34	34	4	4	4	4	4	4	45	45	45	5	5	
H	63.963 - 63.962 (2.5182 - 2.5182)	1	12	12	12	2	2	2	2	23	23	23	3	3	3	34	34	34	4	4	4	4	4	4	45	45	45	5	5	
J	63.962 - 63.961 (2.5182 - 2.5181)	12	12	12	2	2	2	2	23	23	23	3	3	3	34	34	34	4	4	4	4	4	4	45	45	45	5	5		
K	63.961 - 63.960 (2.5181 - 2.5181)	12	12	2	2	2	23	23	23	3	3	3	34	34	34	4	4	4	4	4	45	45	45	5	5	5	5	56		
L	63.960 - 63.959 (2.5181 - 2.5181)	12	2	2	2	23	23	23	3	3	3	34	34	34	4	4	4	4	4	45	45	45	5	5	5	5	56	56		
M	63.959 - 63.958 (2.5181 - 2.5180)	2	2	2	23	23	23	3	3	3	34	34	34	4	4	4	4	4	45	45	45	5	5	5	5	56	56	56		
N	63.958 - 63.957 (2.5180 - 2.5180)	2	2	23	23	23	3	3	3	34	34	34	4	4	4	4	4	4	45	45	45	5	5	5	5	56	56	56	6	
P	63.957 - 63.956 (2.5180 - 2.5179)	2	23	23	23	3	3	3	34	34	34	4	4	4	4	4	4	4	45	45	45	5	5	5	5	56	56	56	6	
R	63.956 - 63.955 (2.5179 - 2.5179)	23	23	23	3	3	3	34	34	34	4	4	4	4	4	4	4	4	45	45	45	5	5	5	5	56	56	56	6	
S	63.955 - 63.954 (2.5179 - 2.5179)	23	23	3	3	3	34	34	34	4	4	4	4	4	4	4	4	4	45	45	45	5	5	5	5	56	56	56	6	
T	63.954 - 63.953 (2.5179 - 2.5178)	23	3	3	3	34	34	34	4	4	4	4	4	4	4	4	4	4	45	45	45	5	5	5	5	56	56	56	6	
U	63.953 - 63.952 (2.5178 - 2.5178)	3	3	3	34	34	34	4	4	4	4	4	4	4	4	4	4	4	45	45	45	5	5	5	5	56	56	56	6	
V	63.952 - 63.951 (2.5178 - 2.5178)	3	3	34	34	34	4	4	4	4	4	4	4	4	4	4	4	4	45	45	45	5	5	5	5	56	56	56	6	
W	63.951 - 63.950 (2.5178 - 2.5177)	3	34	34	34	4	4	4	4	4	4	4	4	4	4	4	4	4	45	45	45	5	5	5	5	56	56	56	6	
X	63.950 - 63.949 (2.5177 - 2.5177)	34	34	34	4	4	4	4	4	4	4	4	4	4	4	4	4	4	45	45	45	5	5	5	5	56	56	56	6	
Y	63.949 - 63.948 (2.5177 - 2.5176)	34	34	4	4	4	4	4	4	4	4	4	4	4	4	4	4	4	45	45	45	5	5	5	5	56	56	56	6	
1	63.948 - 63.947 (2.5176 - 2.5176)	34	4	4	4	4	4	4	4	4	4	4	4	4	4	4	4	4	45	45	45	5	5	5	5	56	56	56	6	
2	63.947 - 63.946 (2.5176 - 2.5176)	4	4	4	4	4	4	4	4	4	4	4	4	4	4	4	4	4	4	45	45	45	5	5	5	5	56	56	56	6
3	63.946 - 63.945 (2.5176 - 2.5175)	4	4	4	4	4	4	4	4	4	4	4	4	4	4	4	4	4	4	45	45	45	5	5	5	5	56	56	56	6
4	63.945 - 63.944 (2.5175 - 2.5175)	4	4	4	4	4	4	4	4	4	4	4	4	4	4	4	4	4	4	45	45	45	5	5	5	5	56	56	56	6
5	63.944 - 63.943 (2.5175 - 2.5174)	4	4	4	4	4	4	4	4	4	4	4	4	4	4	4	4	4	4	45	45	45	5	5	5	5	56	56	56	6
6	63.943 - 63.942 (2.5174 - 2.5174)	4	4	4	4	4	4	4	4	4	4	4	4	4	4	4	4	4	4	45	45	45	5	5	5	5	56	56	56	6
7	63.942 - 63.941 (2.5174 - 2.5174)	4	4	4	4	4	4	4	4	4	4	4	4	4	4	4	4	4	4	45	45	45	5	5	5	5	56	56	56	6
9	63.941 - 63.940 (2.5174 - 2.5173)	5	5	5	5	5	5	5	5	5	5	5	5	5	5	5	5	5	5	5	5	5	5	5	5	5	5	5	5	5

JPBIA2285GB

A
EM
C
D
E
F
G
H
I
J
K
L
M
N
O
P

HOW TO SELECT PISTON AND BEARING

< UNIT DISASSEMBLY AND ASSEMBLY >

[VK50VE]

MAIN BEARING SELECTION TABLE (No. 2, 3 and 4 Journal)

I.D. mark	Axle diameter Unit: mm (in)	Cylinder block main bearing housing inner diameter	Crankshaft main journal diameter	I.D. mark		Hole diameter Unit: mm (in)																																
				A	B	C	D	E	F	G	H	J	K	L	M	N	P	R	S	T	U	V	W	X	Y	4	7											
A	63.964 - 63.963 (2.5183 - 2.5182)	0	0	01	01	01	01	1	1	1	1	12	12	12	12	2	2	2	23	23	23	3	3	3	3	34	34	34	34	4	4	4	4					
B	63.963 - 63.962 (2.5182 - 2.5182)	0	01	01	01	01	1	1	1	1	12	12	12	12	2	2	2	23	23	23	3	3	3	3	3	34	34	34	34	4	4	4	4					
C	63.962 - 63.961 (2.5182 - 2.5181)	01	01	01	1	1	1	1	12	12	12	12	2	2	2	23	23	23	3	3	3	3	3	3	34	34	34	34	4	4	4	4						
D	63.961 - 63.960 (2.5181 - 2.5181)	01	01	1	1	1	1	12	12	12	12	2	2	2	23	23	23	3	3	3	3	3	3	34	34	34	34	4	4	4	4	45						
E	63.960 - 63.959 (2.5181 - 2.5181)	01	1	1	1	1	12	12	12	12	2	2	2	23	23	23	3	3	3	3	3	3	34	34	34	34	4	4	4	4	45	45						
F	63.959 - 63.958 (2.5181 - 2.5180)	1	1	1	12	12	12	2	2	2	2	23	23	23	3	3	3	34	34	34	4	4	4	4	4	4	4	4	4	45	45	45						
G	63.958 - 63.957 (2.5180 - 2.5180)	1	1	12	12	12	2	2	2	2	23	23	23	3	3	3	34	34	34	4	4	4	4	4	4	4	4	4	4	45	45	45	5					
H	63.957 - 63.956 (2.5180 - 2.5179)	1	12	12	12	2	2	2	2	23	23	23	3	3	3	3	34	34	34	4	4	4	4	4	4	4	4	4	4	45	45	45	5	5				
J	63.956 - 63.955 (2.5179 - 2.5179)	12	12	12	2	2	2	2	23	23	23	3	3	3	3	34	34	34	4	4	4	4	4	4	4	4	4	4	4	45	45	45	5	5				
K	63.955 - 63.954 (2.5179 - 2.5179)	12	12	2	2	2	23	23	23	3	3	3	3	34	34	34	4	4	4	4	4	4	4	4	4	4	4	4	4	45	45	45	5	5	56			
L	63.954 - 63.953 (2.5179 - 2.5178)	12	2	2	2	23	23	23	3	3	3	3	34	34	34	4	4	4	4	4	4	4	4	4	4	4	4	4	4	45	45	45	5	5	56	56		
M	63.953 - 63.952 (2.5178 - 2.5178)	2	2	2	23	23	23	3	3	3	3	34	34	34	4	4	4	4	4	4	4	4	4	4	4	4	4	4	4	4	45	45	45	5	5	56	56	
N	63.952 - 63.951 (2.5178 - 2.5178)	2	2	23	23	23	3	3	3	3	34	34	34	4	4	4	4	4	4	4	4	4	4	4	4	4	4	4	4	4	4	45	45	45	5	5	56	56
P	63.951 - 63.950 (2.5178 - 2.5177)	2	23	23	23	3	3	3	3	34	34	34	4	4	4	4	4	4	4	4	4	4	4	4	4	4	4	4	4	4	4	4	4	4	4	4	4	4
R	63.950 - 63.949 (2.5177 - 2.5177)	23	23	23	3	3	3	3	34	34	34	4	4	4	4	4	4	4	4	4	4	4	4	4	4	4	4	4	4	4	4	4	4	4	4	4	4	4
S	63.949 - 63.948 (2.5177 - 2.5176)	23	23	3	3	3	34	34	34	4	4	4	4	4	4	4	4	4	4	4	4	4	4	4	4	4	4	4	4	4	4	4	4	4	4	4	4	4
T	63.948 - 63.947 (2.5176 - 2.5176)	23	3	3	3	34	34	34	4	4	4	4	4	4	4	4	4	4	4	4	4	4	4	4	4	4	4	4	4	4	4	4	4	4	4	4	4	4
U	63.947 - 63.946 (2.5176 - 2.5176)	3	3	3	34	34	34	4	4	4	4	4	4	4	4	4	4	4	4	4	4	4	4	4	4	4	4	4	4	4	4	4	4	4	4	4	4	4
V	63.946 - 63.945 (2.5176 - 2.5175)	3	3	34	34	34	4	4	4	4	4	4	4	4	4	4	4	4	4	4	4	4	4	4	4	4	4	4	4	4	4	4	4	4	4	4	4	4
W	63.945 - 63.944 (2.5175 - 2.5175)	3	34	34	34	4	4	4	4	4	4	4	4	4	4	4	4	4	4	4	4	4	4	4	4	4	4	4	4	4	4	4	4	4	4	4	4	4
X	63.944 - 63.943 (2.5175 - 2.5174)	34	34	34	4	4	4	4	4	4	4	4	4	4	4	4	4	4	4	4	4	4	4	4	4	4	4	4	4	4	4	4	4	4	4	4	4	4
Y	63.943 - 63.942 (2.5174 - 2.5174)	34	34	4	4	4	4	4	4	4	4	4	4	4	4	4	4	4	4	4	4	4	4	4	4	4	4	4	4	4	4	4	4	4	4	4	4	4
1	63.942 - 63.941 (2.5174 - 2.5174)	34	4	4	4	4	4	4	4	4	4	4	4	4	4	4	4	4	4	4	4	4	4	4	4	4	4	4	4	4	4	4	4	4	4	4	4	4
2	63.941 - 63.940 (2.5174 - 2.5173)	4	4	4	4	4	4	4	4	4	4	4	4	4	4	4	4	4	4	4	4	4	4	4	4	4	4	4	4	4	4	4	4	4	4	4	4	4

JPBIA2286GB

MAIN BEARING GRADE TABLE (ALL JOURNALS)

Main bearing grade table (All journals) : Refer to [EM-291, "Main Bearing"](#).

UNDERSIZE BEARING USAGE GUIDE

- When the specified main bearing oil clearance is not obtained with standard size main bearings, use under-size (US) bearing.
- When using under-size (US) bearing, measure the main bearing inner diameter with bearing installed, and grind main journal so that the main bearing oil clearance satisfies the standard.

CAUTION:

HOW TO SELECT PISTON AND BEARING

< UNIT DISASSEMBLY AND ASSEMBLY >

[VK50VE]

In grinding crankshaft main journal to use undersize bearings, keep the fillet R (A) [1.5 - 1.7 mm (0.059 - 0.067 in)].

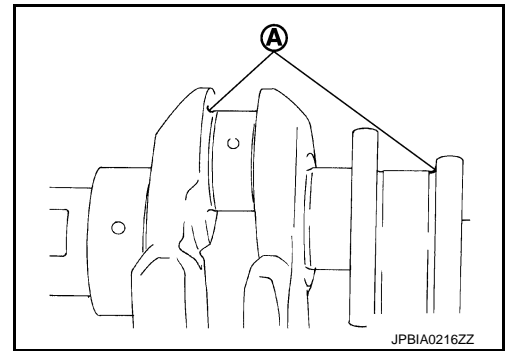

A

EM

C

D

Bearing undersize table : Refer to [EM-291, "Main Bearing"](#).

E

F

G

H

I

J

K

L

M

N

O

P

SERVICE DATA AND SPECIFICATIONS (SDS)

< SERVICE DATA AND SPECIFICATIONS (SDS)

[VK50VE]

SERVICE DATA AND SPECIFICATIONS (SDS)

SERVICE DATA AND SPECIFICATIONS (SDS)

General Specification

INFOID:000000003733463

GENERAL SPECIFICATIONS

Cylinder arrangement	V-8	
Displacement cm ³ (cu in)	5,026 (306.69)	
Bore and stroke mm (in)	95.5 x 87.7 (3.76 x 3.453)	
Valve arrangement	DOHC	
Firing order	1-8-7-3-6-5-4-2	
Number of piston rings	Compression	2
	Oil	1
Number of main bearings	5	
Compression ratio	10.9	
Compression pressure kPa (kg/cm ² , psi)/200 rpm	Standard	1,667 (17, 242)
	Minimum	1,226 (12.5, 178)
	Differential limit between cylinders	98 (1.0, 14)

Cylinder number

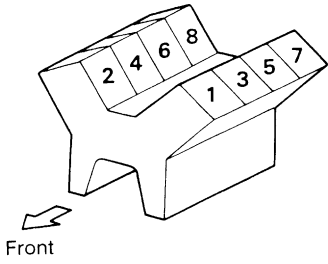

SEM957C

Unit: degree

Valve timing	Intake valve open (BTDC)	-66 - 61
	Intake valve close (ABDC)	-71 - 84
	Exhaust valve open (BBDC)	32 - 62
	Exhaust valve close (ATDC)	-2 - 28

Drive Belts

INFOID:000000003733464

DRIVE BELT

Tension of drive belts	Belt tension is not necessary, as it is automatically adjusted by drive belt auto-tensioner.
------------------------	--

Spark Plug

INFOID:000000003733465

SPARK PLUG

Unit: mm (in)

Make	DENSO
Standard type	FXE22HR11

SERVICE DATA AND SPECIFICATIONS (SDS)

< SERVICE DATA AND SPECIFICATIONS (SDS)

[VK50VE]

Gap	Standard	1.1 (0.043)
	Limit	1.4 (0.055)

Exhaust Manifold

INFOID:000000003733467

EXHAUST MANIFOLD

Unit: mm (in)

Items		Limit
Surface distortion	Exhaust manifold	0.7 (0.028)

Camshaft

INFOID:000000003733468

CAMSHAFT (EXH)

Unit: mm (in)

Items		Standard	Limit
Camshaft (EXH) journal oil clearance	No. 1	0.045 - 0.086 (0.0018 - 0.0034)	0.150 (0.0059)
	No. 2, 3, 4, 5	0.030 - 0.071 (0.0012 - 0.0028)	
VVEL ladder assembly bracket inner diameter (EXH side)		26.000 - 26.021 (1.0236 - 1.0244)	—
Camshaft (EXH) journal diameter	No. 1	25.935 - 25.955 (1.0211 - 1.0218)	—
	No. 2, 3, 4, 5	25.950 - 25.970 (1.0217 - 1.0224)	—
Camshaft (EXH) end play		0.115 - 0.188 (0.0045 - 0.0074)	0.24 (0.0094)
Camshaft (EXH) cam height "A"		45.475 - 45.665 (1.7904 - 1.7978)	44.275 (1.7431)
Camshaft (EXH) runout [TIR*]		Less than 0.02 mm (0.0008)	0.05 (0.002)
Camshaft sprocket (EXH) runout [TIR*]		—	0.2 (0.0079)

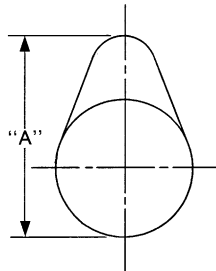

SEM671

*: Total indicator reading

CAMSHAFT (INT)

Unit: mm (in)

Items	Standard	Limit
Drive shaft end play	0.115 - 0.188 (0.0045 - 0.0074)	0.24 (0.0094)
Camshaft sprocket (INT) runout [TIR* ¹]	—	0.15 (0.0059)

*¹: Total indicator reading

VALVE LIFTER

Unit: mm (in)

Items	Standard
Valve lifter outer diameter	33.980 - 33.990 (1.3378 - 1.3382)
Valve lifter hole diameter	34.000 - 34.016 (1.3386 - 1.3392)
Valve lifter clearance	0.010 - 0.036 (0.0004 - 0.0014)

SERVICE DATA AND SPECIFICATIONS (SDS)

< SERVICE DATA AND SPECIFICATIONS (SDS)

[VK50VE]

VALVE CLEARANCE

Unit: mm (in)

Items	Cold	Hot* (reference data)
Intake	0.26 - 0.34 (0.010 - 0.013)	0.304 - 0.416 (0.012 - 0.016)
Exhaust	0.29 - 0.37 (0.011 - 0.015)	0.308 - 0.432 (0.012 - 0.017)

*: Approximately 80°C (176°F)

AVAILABLE VALVE LIFTER

Unit: mm (in)

Identification (stamped) mark	Thickness
788P	7.88 (0.3102)
790P	7.90 (0.3110)
792P	7.92 (0.3118)
794P	7.94 (0.3126)
796P	7.96 (0.3134)
798P	7.98 (0.3142)
800P	8.00 (0.3150)
802P	8.02 (0.3157)
804P	8.04 (0.3165)
806P	8.06 (0.3173)
808P	8.08 (0.3181)
810P	8.10 (0.3189)
812P	8.12 (0.3197)
814P	8.14 (0.3205)
816P	8.16 (0.3213)
818P	8.18 (0.3220)
820P	8.20 (0.3228)
822P	8.22 (0.3236)
824P	8.24 (0.3244)
826P	8.26 (0.3252)
828P	8.28 (0.3260)
830P	8.30 (0.3268)
832P	8.32 (0.3276)
834P	8.34 (0.3283)
836P	8.36 (0.3291)
838P	8.38 (0.3299)
840P	8.40 (0.3307)

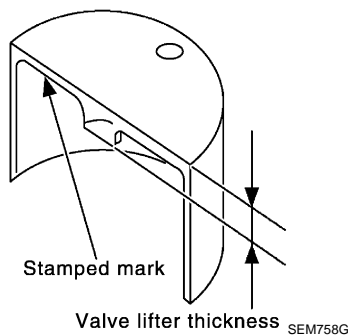

SERVICE DATA AND SPECIFICATIONS (SDS)

< SERVICE DATA AND SPECIFICATIONS (SDS)

[VK50VE]

Cylinder Head

INFOID:000000003733469

CYLINDER HEAD

Unit: mm (in)

Items	Standard	Limit
Head surface distortion	Less than 0.03 (0.0012)	0.1 (0.004)
Normal cylinder head height "H"	126.4 (4.98)	—

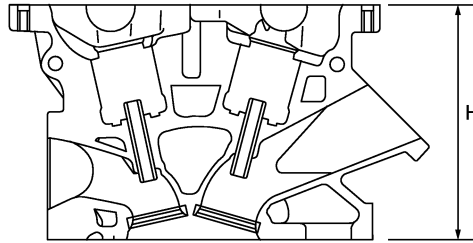

PBIC0924E

VALVE DIMENSIONS

Unit: mm (in)

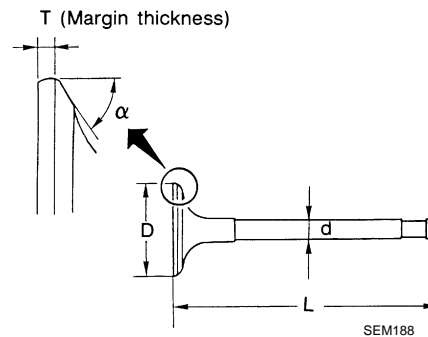

SEM188

Valve head diameter "D"	Intake	36.6 - 36.9 (1.441 - 1.453)
	Exhaust	30.2 - 30.5 (1.189 - 1.201)
Valve length "L"	Intake	100.11 (3.94)
	Exhaust	94.67 (3.7272)
Valve stem diameter "d"	Intake	5.965 - 5.980 (0.2348 - 0.2354)
	Exhaust	5.955 - 5.970 (0.2344 - 0.2350)
Valve seat angle " α "	Intake	45°15' - 45°45'
	Exhaust	
Valve margin "T"	Intake	1.1 (0.043)
	Exhaust	1.3 (0.051)
Valve margin "T" limit		0.5 (0.020)
Valve stem end surface grinding limit		0.2 (0.008)

VALVE GUIDE

SERVICE DATA AND SPECIFICATIONS (SDS)

< SERVICE DATA AND SPECIFICATIONS (SDS)

[VK50VE]

Unit: mm (in)

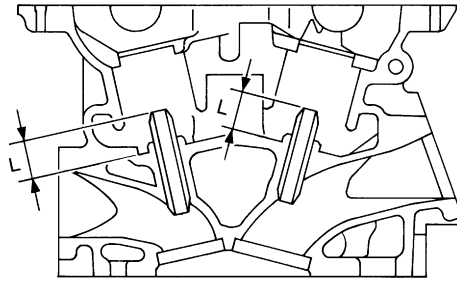

SEM950E

Items		Standard	Oversize (Service) [0.2 (0.008)]*
Valve guide	Outer diameter	10.023 - 10.034 (0.3946 - 0.3950)	10.223 - 10.234 (0.4025 - 0.4029)*
	Inner diameter (Finished size)	6.000 - 6.018 (0.2362 - 0.2369)	
Cylinder head valve guide hole diameter		9.975 - 9.996 (0.3927 - 0.3935)	10.175 - 10.196 (0.4006 - 0.4014)*
Interference fit of valve guide		0.027 - 0.059 (0.0011 - 0.0023)	
Items		Standard	Limit
Valve guide clearance	Intake	0.020 - 0.053 (0.0008 - 0.0021)	0.08 (0.003)
	Exhaust	0.030 - 0.063 (0.0012 - 0.0025)	0.09 (0.004)
Projection length "L"	Intake	12.6 - 12.8 (0.496 - 0.504)	
	Exhaust	11.9 - 12.1 (0.469 - 0.476)	

*: Parts settings are for exhaust side only

VALVE SEAT

Unit: mm (in)

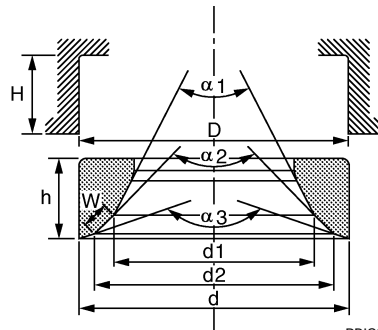

PBIC2745E

Items		Standard	Oversize (Service) [0.5 (0.02)] *4
Cylinder head seat recess diameter "D"	Intake	38.000 - 38.016 (1.4961 - 1.4967)	—
	Exhaust	31.600 - 31.616 (1.2441 - 1.2447)	32.100 - 32.116 (1.2638 - 1.2644)*4
Valve seat outer diameter "d"	Intake	38.097 - 38.113 (1.4999 - 1.5005)	—
	Exhaust	31.680 - 31.696 (1.2472 - 1.2479)	32.180 - 32.196 (1.2669 - 1.2676)*4
Valve seat interference fit	Intake	0.081 - 0.113 (0.0032 - 0.0044)	
	Exhaust	0.064 - 0.096 (0.0025 - 0.0038)	
Diameter "d1"*1	Intake	34.6 (1.362)	
	Exhaust	27.7 (1.091)	
Diameter "d2"*2	Intake	35.9 - 36.4 (1.413 - 1.433)	
	Exhaust	29.3 - 29.8 (1.154 - 1.173)	
Angle "alpha 1"		59 - 61°	

SERVICE DATA AND SPECIFICATIONS (SDS)

< SERVICE DATA AND SPECIFICATIONS (SDS)

[VK50VE]

Angle "α2"		88°45' - 90°15'	
Angle "α3"		119 - 121°	
Contacting width "W"*3	Intake	1.0 - 1.4 (0.039 - 0.055)	
	Exhaust	1.2 - 1.6 (0.047 - 0.063)	
Height "h"	Intake	5.9 - 6.0 (0.232 - 0.236)	—
	Exhaust	5.9 - 6.0 (0.232 - 0.236)	4.9 - 5.0 (0.1949 - 0.1988)*4
Depth "H"		6.0 (0.236)	

*1: Diameter made by intersection point of conic angles "α1" and "α2"

*2: Diameter made by intersection point of conic angles "α2" and "α3"

*3: Machining data

*4: Parts settings are for exhaust side only

VALVE SPRING

Item		Standard	
		Intake	Exhaust
Free height		48.69 mm (1.9169 in)	47.35 mm (1.8642 in)
Pressure	Installation	162 - 192 N (16.5 - 19.6 kg, 36 - 43 lb) at 42.40 mm (1.6693 in)	163 - 191 N (16.6 - 19.5 kg, 37 - 43 lb) at 35.45 mm (1.3957 in)
	Valve open	609 - 695 N (62.1 - 70.9 kg, 137 - 156 lb) at 28.83 mm (1.1350 in)	370 - 426 N (37.7 - 43.5 kg, 83 - 96 lb) at 25.65 mm (1.0098 in)
Identification color		Yellow	Pink

Item		Limit	
		Intake	Exhaust
Out-of-square		2.1 mm (0.083 in)	2.0 mm (0.079 in)

Cylinder Block

INFOID:000000003733470

CYLINDER BLOCK

Unit: mm (in)

Surface flatness		Limit		0.1 (0.004)
Main bearing housing inner diameter		Standard		68.944 - 68.968 (2.7143 - 2.7153)
Cylinder bore	Inner diameter	Standard	Grade No. 1	95.500 - 95.510 (3.7598 - 3.7602)
			Grade No. 2	95.510 - 95.520 (3.7602 - 3.7606)
			Grade No. 3	95.520 - 95.530 (3.7606 - 3.7610)
		Wear limit	0.2 (0.008)	
Out-of-round		Limit		0.015 (0.0006)
Taper				0.010 (0.0004)

SERVICE DATA AND SPECIFICATIONS (SDS)

< SERVICE DATA AND SPECIFICATIONS (SDS)

[VK50VE]

Main bearing housing inner diameter grade (Without bearing)	Grade No. A	68.944 - 68.945 (2.7143 - 2.7144)
	Grade No. B	68.945 - 68.946 (2.7144 - 2.7144)
	Grade No. C	68.946 - 68.947 (2.7144 - 2.7144)
	Grade No. D	68.947 - 68.948 (2.7144 - 2.7145)
	Grade No. E	68.948 - 68.949 (2.7145 - 2.7145)
	Grade No. F	68.949 - 68.950 (2.7145 - 2.7146)
	Grade No. G	68.950 - 68.951 (2.7146 - 2.7146)
	Grade No. H	68.951 - 68.952 (2.7146 - 2.7146)
	Grade No. J	68.952 - 68.953 (2.7146 - 2.7147)
	Grade No. K	68.953 - 68.954 (2.7147 - 2.7147)
	Grade No. L	68.954 - 68.955 (2.7147 - 2.7148)
	Grade No. M	68.955 - 68.956 (2.7148 - 2.7148)
	Grade No. N	68.956 - 68.957 (2.7148 - 2.7148)
	Grade No. P	68.957 - 68.958 (2.7148 - 2.7149)
	Grade No. R	68.958 - 68.959 (2.7149 - 2.7149)
	Grade No. S	68.959 - 68.960 (2.7149 - 2.7150)
	Grade No. T	68.960 - 68.961 (2.7150 - 2.7150)
	Grade No. U	68.961 - 68.962 (2.7150 - 2.7150)
	Grade No. V	68.962 - 68.963 (2.7150 - 2.7151)
Grade No. W	68.963 - 68.964 (2.7151 - 2.7151)	
Grade No. X	68.964 - 68.965 (2.7151 - 2.7152)	
Grade No. Y	68.965 - 68.966 (2.7152 - 2.7152)	
Grade No. 4	68.966 - 68.967 (2.7152 - 2.7152)	
Grade No. 7	68.967 - 68.968 (2.7152 - 2.7153)	
Difference in inner diameter between cylinders	Standard	Less than 0.03 (0.0012)

AVAILABLE PISTON

Unit: mm (in)

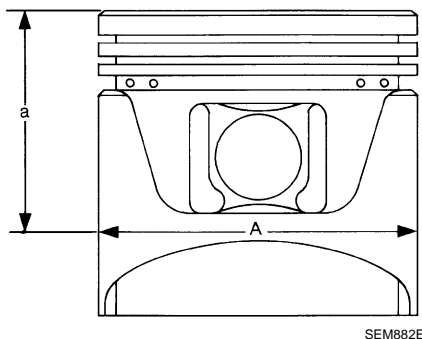

Items	Standard	Oversize (Service) [0.2 (0.008)]
Piston skirt diameter "A"	Grade No. 1	95.480 - 95.490 (3.7590 - 3.7594)
	Grade No. 2	95.490 - 95.500 (3.7594 - 3.7598)
	Grade No. 3	95.500 - 95.510 (3.7598 - 3.7602)
	Service	—
95.680 - 95.710 (3.7669 - 3.7681)		
Items	Standard	Limit
"a" dimension	38.8 (1.528)	—
Piston pin hole diameter	21.993 - 21.999 (0.8659 - 0.8661)	—
Piston to cylinder bore clearance	0.010 - 0.030 (0.0004 - 0.0012)	0.08 (0.0031)

PISTON RING

Unit: mm (in)

Items	Standard	Limit
Side clearance	Top	0.040 - 0.080 (0.0016 - 0.0031)
	2nd	0.030 - 0.070 (0.0012 - 0.0028)
	Oil ring	0.055 - 0.155 (0.0022 - 0.0061)
		0.11 (0.0043)
		0.10 (0.0039)
		0.19 (0.0075)

SERVICE DATA AND SPECIFICATIONS (SDS)

< SERVICE DATA AND SPECIFICATIONS (SDS)

[VK50VE]

End gap	Top	0.23 - 0.33 (0.0091 - 0.0130)	0.55 (0.0217)
	2nd	0.33 - 0.48 (0.0130 - 0.0189)	0.67 (0.0264)
	Oil (rail ring)	0.17 - 0.47 (0.0067 - 0.0185)	0.82 (0.0323)

PISTON PIN

Unit: mm (in)

Items	Standard	Limit
Piston pin outer diameter	21.989 - 21.995 (0.8657 - 0.8659)	—
Piston to piston pin oil clearance	0.002 - 0.006 (0.0001 - 0.0002)	—
Connecting rod bushing oil clearance	0.005 - 0.017 (0.0002 - 0.0007)	0.030 (0.0012)

CONNECTING ROD

Unit: mm (in)

Items	Standard	Limit
Center distance	157.68 - 157.78 (6.21 - 6.21)	—
Bend [per 100 (3.94)]	—	0.15 (0.0059)
Torsion [per 100 (3.94)]	—	0.30 (0.0118)
Connecting rod bushing inner diameter*	22.000 - 22.006 (0.8661 - 0.8664)	—
Connecting rod big end diameter (Without bearing)	Grade No. A	57.000 - 57.001 (2.2441 - 2.2441)
	Grade No. B	57.001 - 57.002 (2.2441 - 2.2442)
	Grade No. C	57.002 - 57.003 (2.2442 - 2.2442)
	Grade No. D	57.003 - 57.004 (2.2442 - 2.2442)
	Grade No. E	57.004 - 57.005 (2.2442 - 2.2443)
	Grade No. F	57.005 - 57.006 (2.2443 - 2.2443)
	Grade No. G	57.006 - 57.007 (2.2443 - 2.2444)
	Grade No. H	57.007 - 57.008 (2.2444 - 2.2444)
	Grade No. J	57.008 - 57.009 (2.2444 - 2.2444)
	Grade No. K	57.009 - 57.010 (2.2444 - 2.2445)
	Grade No. L	57.010 - 57.011 (2.2445 - 2.2445)
Grade No. M	57.011 - 57.012 (2.2445 - 2.2446)	
Grade No. N	57.012 - 57.013 (2.2446 - 2.2446)	
Side clearance	0.20 - 0.35 (0.0079 - 0.0138)	0.40 (0.0157)

*: After installing in connecting rod

CRANKSHAFT

SERVICE DATA AND SPECIFICATIONS (SDS)

< SERVICE DATA AND SPECIFICATIONS (SDS)

[VK50VE]

Unit: mm (in)

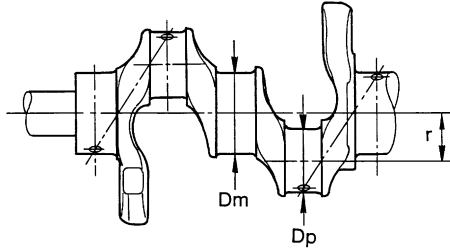

Main journal diameter. "Dm" grade (No. 1 and 5 journal)	Standard	Grade No. G Grade No. H Grade No. J Grade No. K Grade No. L Grade No. M Grade No. N Grade No. P Grade No. R Grade No. S Grade No. T Grade No. U Grade No. V Grade No. W Grade No. X Grade No. Y Grade No. 1 Grade No. 2 Grade No. 3 Grade No. 4 Grade No. 5 Grade No. 6 Grade No. 7 Grade No. 9	63.964 - 63.963 (2.5183 - 2.5182) 63.963 - 63.962 (2.5182 - 2.5182) 63.962 - 63.961 (2.5182 - 2.5181) 63.961 - 63.960 (2.5181 - 2.5181) 63.960 - 63.959 (2.5181 - 2.5181) 63.959 - 63.958 (2.5181 - 2.5180) 63.958 - 63.957 (2.5180 - 2.5180) 63.957 - 63.956 (2.5180 - 2.5179) 63.956 - 63.955 (2.5179 - 2.5179) 63.955 - 63.954 (2.5179 - 2.5179) 63.954 - 63.953 (2.5179 - 2.5178) 63.953 - 63.952 (2.5178 - 2.5178) 63.952 - 63.951 (2.5178 - 2.5178) 63.951 - 63.950 (2.5178 - 2.5177) 63.950 - 63.949 (2.5177 - 2.5177) 63.949 - 63.948 (2.5177 - 2.5176) 63.948 - 63.947 (2.5176 - 2.5176) 63.947 - 63.946 (2.5176 - 2.5176) 63.946 - 63.945 (2.5176 - 2.5175) 63.945 - 63.944 (2.5175 - 2.5175) 63.944 - 63.943 (2.5175 - 2.5174) 63.943 - 63.942 (2.5174 - 2.5174) 63.942 - 63.941 (2.5174 - 2.5174) 63.941 - 63.940 (2.5174 - 2.5173)
Main journal diameter. "Dm" grade (No. 2, 3 and 4 journal)	Standard	Grade No. A Grade No. B Grade No. C Grade No. D Grade No. E Grade No. F Grade No. G Grade No. H Grade No. J Grade No. K Grade No. L Grade No. M Grade No. N Grade No. P Grade No. R Grade No. S Grade No. T Grade No. U Grade No. V Grade No. W Grade No. X Grade No. Y Grade No. 1 Grade No. 2	63.963 - 63.964 (2.5182 - 2.5183) 63.962 - 63.963 (2.5182 - 2.5182) 63.961 - 63.962 (2.5181 - 2.5182) 63.960 - 63.961 (2.5181 - 2.5181) 63.959 - 63.960 (2.5181 - 2.5181) 63.958 - 63.959 (2.5180 - 2.5181) 63.957 - 63.958 (2.5180 - 2.5180) 63.956 - 63.957 (2.5179 - 2.5180) 63.955 - 63.956 (2.5179 - 2.5179) 63.954 - 63.955 (2.5179 - 2.5179) 63.953 - 63.954 (2.5178 - 2.5179) 63.952 - 63.953 (2.5178 - 2.5178) 63.951 - 63.952 (2.5178 - 2.5178) 63.950 - 63.951 (2.5177 - 2.5178) 63.949 - 63.950 (2.5177 - 2.5177) 63.948 - 63.949 (2.5176 - 2.5177) 63.947 - 63.948 (2.5176 - 2.5176) 63.946 - 63.947 (2.5176 - 2.5176) 63.945 - 63.946 (2.5175 - 2.5176) 63.944 - 63.945 (2.5175 - 2.5175) 63.943 - 63.944 (2.5174 - 2.5175) 63.942 - 63.943 (2.5174 - 2.5174) 63.941 - 63.942 (2.5174 - 2.5174) 63.940 - 63.941 (2.5173 - 2.5174)

SERVICE DATA AND SPECIFICATIONS (SDS)

< SERVICE DATA AND SPECIFICATIONS (SDS)

[VK50VE]

Pin journal diameter. "Dp" grade	Standard	Grade No. A	53.974 - 53.973 (2.1250 - 2.1249)	A
		Grade No. B	53.973 - 53.972 (2.1249 - 2.1249)	
		Grade No. C	53.972 - 53.971 (2.1249 - 2.1248)	
		Grade No. D	53.971 - 53.970 (2.1248 - 2.1248)	
		Grade No. E	53.970 - 53.969 (2.1248 - 2.1248)	
		Grade No. F	53.969 - 53.968 (2.1248 - 2.1247)	EM
		Grade No. G	53.968 - 53.967 (2.1247 - 2.1247)	
		Grade No. H	53.967 - 53.966 (2.1247 - 2.1246)	
		Grade No. J	53.966 - 53.965 (2.1246 - 2.1246)	C
		Grade No. K	53.965 - 53.964 (2.1246 - 2.1246)	
		Grade No. L	53.964 - 53.963 (2.1246 - 2.1245)	
		Grade No. M	53.963 - 53.962 (2.1245 - 2.1245)	
		Grade No. N	53.962 - 53.961 (2.1245 - 2.1244)	D
		Grade No. P	53.961 - 53.960 (2.1244 - 2.1244)	
		Grade No. R	53.960 - 53.959 (2.1244 - 2.1244)	
		Grade No. S	53.959 - 53.958 (2.1244 - 2.1243)	
		Grade No. T	53.958 - 53.957 (2.1243 - 2.1243)	E
Grade No. U	53.957 - 53.956 (2.1243 - 2.1242)			
Center distance "r"			43.81 - 43.89 (1.7248 - 1.7279)	
Taper	Limit	0.0025 (0.0001)		F
Out-of-round		0.0025 (0.0001)		
Crankshaft runout [TIR*]	Standard	Less than 0.05 (0.002)		G
	Limit	0.10 (0.0039)		
Crankshaft end play	Standard	0.10 - 0.26 (0.0039 - 0.0102)		
	Limit	0.30 (0.012)		H

*: Total indicator reading

Main Bearing

INFOID:000000003733471

MAIN BEARING

SERVICE DATA AND SPECIFICATIONS (SDS)

< SERVICE DATA AND SPECIFICATIONS (SDS)

[VK50VE]

Grade number	Thickness mm (in)	Width mm (in)	Identification color	Remarks	
0	2.483 - 2.486 (0.0978 - 0.0979)	19.9 - 20.1 (0.783 - 0.791)	Black	Grade is the same for upper and lower bearings.	
1	2.486 - 2.489 (0.0979 - 0.0980)		Brown		
2	2.489 - 2.492 (0.0980 - 0.0981)		Green		
3	2.492 - 2.495 (0.0981 - 0.0982)		Yellow		
4	2.495 - 2.498 (0.0982 - 0.0983)		Blue		
5	2.498 - 2.501 (0.0983 - 0.0985)		Pink		
6	2.501 - 2.504 (0.0985 - 0.0986)		Purple		
7	2.504 - 2.507 (0.0986 - 0.0987)		White		
8	2.507 - 2.510 (0.0987 - 0.0988)		Red	Grade and color are different for upper and lower bearings.	
01	UPR		2.483 - 2.486 (0.0978 - 0.0979)		Black
	LWR		2.486 - 2.489 (0.0979 - 0.0980)		Brown
12	UPR		2.486 - 2.489 (0.0979 - 0.0980)		Brown
	LWR		2.489 - 2.492 (0.0980 - 0.0981)		Green
23	UPR		2.489 - 2.492 (0.0980 - 0.0981)		Green
	LWR		2.492 - 2.495 (0.0981 - 0.0982)		Yellow
34	UPR		2.492 - 2.495 (0.0981 - 0.0982)		Yellow
	LWR	2.495 - 2.498 (0.0982 - 0.0983)	Blue		
45	UPR	2.495 - 2.498 (0.0982 - 0.0983)	Blue		
	LWR	2.498 - 2.501 (0.0983 - 0.0985)	Pink		
56	UPR	2.498 - 2.501 (0.0983 - 0.0985)	Pink		
	LWR	2.501 - 2.504 (0.0985 - 0.0986)	Purple		
67	UPR	2.501 - 2.504 (0.0985 - 0.0986)	Purple		
	LWR	2.504 - 2.507 (0.0986 - 0.0987)	White		
78	UPR	2.504 - 2.507 (0.0986 - 0.0987)	White		
	LWR	2.507 - 2.510 (0.0987 - 0.0988)	Red		

UNDERSIZE

Unit: mm (in)

Items	Thickness	Main journal diameter
0.25 (0.0098)	2.618 - 2.626 (0.1031 - 0.1034)	Grind so that bearing clearance is the specified value.

MAIN BEARING OIL CLEARANCE

Unit: mm (in)

Items	Standard	Limit
Main bearing oil clearance	0.035 - 0.045 (0.0014 - 0.0018)*	0.065 (0.0026)

*: Actual clearance

Connecting Rod Bearing

INFOID:000000003733472

CONNECTING ROD BEARING

Grade number	Thickness mm (in)	Width mm (in)	Identification color (mark)
0	1.497 - 1.500 (0.0589 - 0.0591)	18.1 - 18.3 (0.713 - 0.720)	Red
1	1.500 - 1.503 (0.0591 - 0.0592)		Black
2	1.503 - 1.506 (0.0592 - 0.0593)		Brown
3	1.506 - 1.509 (0.0593 - 0.0594)		Green
4	1.509 - 1.512 (0.0594 - 0.0595)		Yellow

SERVICE DATA AND SPECIFICATIONS (SDS)

< SERVICE DATA AND SPECIFICATIONS (SDS)

[VK50VE]

UNDERSIZE

Unit: mm (in)

Items	Thickness	Pin journal diameter
0.25 (0.0098)	1.626 - 1.634 (0.0640 - 0.0643)	Grind so that bearing clearance is the specified value.

CONNECTING ROD BEARING OIL CLEARANCE

Unit: mm (in)

Items	Standard	Limit
Connecting rod bearing oil clearance	0.040 - 0.053 (0.0016 - 0.0021)*	0.070 (0.0028)

*: Actual clearance

A

EM

C

D

E

F

G

H

I

J

K

L

M

N

O

P