

SECTION **INT**  
INTERIOR

A  
B  
C  
D  
E  
F  
G  
H  
I  
INT  
K  
L  
M  
N  
O  
P

CONTENTS

<b>SYMPTOM DIAGNOSIS</b> .....	2	Exploded View .....	11
<b>SQUEAK AND RATTLE TROUBLE DIAG- NOSES</b> .....	2	Removal and Installation .....	11
Work Flow .....	2	Disassembly and Assembly .....	13
Inspection Procedure .....	4	<b>REAR DOOR FINISHER</b> .....	14
Diagnostic Worksheet .....	6	Exploded View .....	14
<b>PRECAUTION</b> .....	8	Removal and Installation .....	14
<b>PRECAUTIONS</b> .....	8	Disassembly and Assembly .....	16
Precaution for Supplemental Restraint System (SRS) "AIR BAG" and "SEAT BELT PRE-TEN- SIONER" .....	8	<b>BODY SIDE TRIM</b> .....	17
Precaution Necessary for Steering Wheel Rota- tion after Battery Disconnect .....	8	Exploded View .....	17
Precaution for Procedure without Cowl Top Cover.....	9	Removal and Installation .....	17
Precaution for Work .....	9	<b>FLOOR TRIM</b> .....	21
<b>PREPARATION</b> .....	10	Exploded View .....	21
<b>PREPARATION</b> .....	10	Removal and Installation .....	21
Special Service Tools .....	10	<b>HEADLINING</b> .....	23
Commercial Service Tools .....	10	Exploded View .....	23
<b>REMOVAL AND INSTALLATION</b> .....	11	Removal and Installation .....	24
<b>FRONT DOOR FINISHER</b> .....	11	<b>LUGGAGE FLOOR TRIM</b> .....	28
		Exploded View .....	28
		Removal and Installation .....	29
		<b>BACK DOOR TRIM</b> .....	32
		Exploded View .....	32
		Removal and Installation .....	32

# SQUEAK AND RATTLE TROUBLE DIAGNOSES

< SYMPTOM DIAGNOSIS >

## SYMPTOM DIAGNOSIS

### SQUEAK AND RATTLE TROUBLE DIAGNOSES

#### Work Flow

INFOID:000000004062135

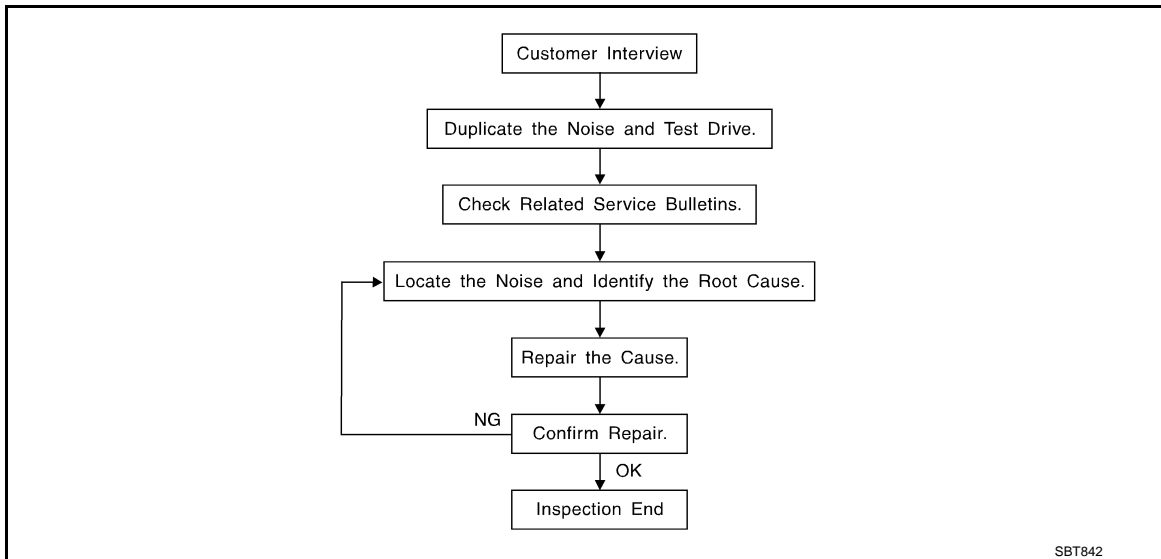

#### CUSTOMER INTERVIEW

Interview the customer if possible, to determine the conditions that exist when the noise occurs. Use the Diagnostic Worksheet during the interview to document the facts and conditions when the noise occurs and any of customer's comments; refer to [INT-6. "Diagnostic Worksheet"](#). This information is necessary to duplicate the conditions that exist when the noise occurs.

- The customer may not be able to provide a detailed description or the location of the noise. Attempt to obtain all the facts and conditions that exist when the noise occurs (or does not occur).
- If there is more than one noise in the vehicle, perform a diagnosis and repair the noise that the customer is concerned about. This can be accomplished by performing a cruise test on the vehicle with the customer.
- After identifying the type of noise, isolate the noise in terms of its characteristics. The noise characteristics are provided so the customer, service adviser and technician are all speaking the same language when defining the noise.
- Squeak – (Like tennis shoes on a clean floor)  
Squeak characteristics include the light contact/fast movement/brought on by road conditions/hard surfaces = higher pitch noise/softer surfaces = lower pitch noises/edge to surface = chirping
- Creak – (Like walking on an old wooden floor)  
Creak characteristics include firm contact/slow movement/twisting with a rotational movement/pitch dependent on materials/often brought on by activity.
- Rattle – (Like shaking a baby rattle)  
Rattle characteristics include the fast repeated contact/vibration or similar movement/loose parts/missing clip or fastener/incorrect clearance.
- Knock – (Like a knock on a door)  
Knock characteristics include hollow sounding/sometimes repeating/often brought on by driver action.
- Tick – (Like a clock second hand)  
Tick characteristics include gentle contacting of light materials/loose components/can be caused by driver action or road conditions.
- Thump – (Heavy, muffled knock noise)  
Thump characteristics include softer knock/dead sound often brought on by activity.
- Buzz – (Like a bumblebee)  
Buzz characteristics include high frequency rattle/firm contact.
- Often the degree of acceptable noise level will vary depending up on the person. A noise that a technician may judge as acceptable may be very irritating to the customer.
- Weather conditions, especially humidity and temperature, may have a great effect on noise level.

#### DUPLICATE THE NOISE AND TEST DRIVE

# SQUEAK AND RATTLE TROUBLE DIAGNOSES

## < SYMPTOM DIAGNOSIS >

If possible, drive the vehicle with the customer until the noise is duplicated. Note any additional information on the Diagnostic Worksheet regarding the conditions or location of the noise. This information can be used to duplicate the same conditions when the repair is reconfirmed.

If the noise can be duplicated easily during the test drive, to help identify the source of the noise, try to duplicate the noise with the vehicle stopped by doing one or all of the following:

- 1) Close a door.
  - 2) Tap or push/pull around the area where the noise appears to be coming from.
  - 3) Rev the engine.
  - 4) Use a floor jack to recreate vehicle "twist".
  - 5) At idle, apply engine load (electrical load, half-clutch on M/T models, drive position on A/T models).
  - 6) Raise the vehicle on a hoist and hit a tire with a rubber hammer.
- Drive the vehicle and attempt to duplicate the conditions the customer states exist when the noise occurs.
  - If it is difficult to duplicate the noise, drive the vehicle slowly on an undulating or rough road to stress the vehicle body.

## CHECK RELATED SERVICE BULLETINS

After verifying the customer concern or symptom, check ASIST for Technical Service Bulletins (TSBs) related to that concern or symptom.

If a TSB relates to the symptom, follow the procedure to repair the noise.

## LOCATE THE NOISE AND IDENTIFY THE ROOT CAUSE

1. Narrow down the noise to a general area. To help pinpoint the source of the noise, use a listening tool (Chassis ear: J-39570, Engine ear and mechanics stethoscope).
2. Narrow down the noise to a more specific area and identify the cause of the noise by:
  - Removing the components in the area that is are suspected to be the cause of the noise.  
Do not use too much force when removing clips and fasteners, otherwise clips and fastener can be broken or lost during the repair, resulting in the creation of new noise.
  - Tapping or pushing/pulling the component that is are suspected to be the cause of the noise.  
Do not tap or push/pull the component with excessive force, otherwise the noise will be eliminated only temporarily.
  - Feeling for a vibration by hand by touching the component(s) that is are suspected to be the cause of the noise.
  - Placing a piece of paper between components that are suspected to be the cause of the noise.
  - Looking for loose components and contact marks.  
Refer to [INT-4, "Inspection Procedure"](#).

## REPAIR THE CAUSE

- If the cause is a loose component, tighten the component securely.
- If the cause is insufficient clearance between components:
  - Separate components by repositioning or loosening and retightening the component, if possible.
  - Insulate components with a suitable insulator such as urethane pads, foam blocks, felt cloth tape or urethane tape. A Nissan Squeak and Rattle Kit (J-43980) is available through the authorized Nissan Parts Department.

### **CAUTION:**

**Never use excessive force as many components are constructed of plastic and may be damaged.**

### **NOTE:**

Always check with the Parts Department for the latest parts information.

The following materials are contained in the Nissan Squeak and Rattle Kit (J-43980). Each item can be ordered separately as needed.

URETHANE PADS [1.5 mm (0.059 in) thick]

Insulates connectors, harness, etc.

76268-9E005: 100 × 135 mm (3.94 × 5.31 in)/76884-71L01: 60 × 85 mm (2.36 × 3.35 in)/76884-71L02: 15 × 25 mm (0.59 × 0.98 in)

INSULATOR (Foam blocks)

Insulates components from contact. Can be used to fill space behind a panel.

73982-9E000: 45 mm (1.77 in) thick, 50 × 50 mm (1.97 × 1.97 in)/73982-

50Y00: 10 mm (0.39 in) thick, 50 × 50 mm (1.97 × 1.97 in)

INSULATOR (Light foam block)

80845-71L00: 30 mm (1.18 in) thick, 30 × 50 mm (1.18 × 1.97in)

FELT CLOTHTAPE

Used to insulate where movement does not occur. Ideal for instrument panel applications.

# SQUEAK AND RATTLE TROUBLE DIAGNOSES

## < SYMPTOM DIAGNOSIS >

68370-4B000: 15 × 25 mm (0.59 × 0.98 in) pad/68239-13E00: 5 mm (0.20 in) wide tape roll

The following materials, not found in the kit, can also be used to repair squeaks and rattles.

### UHMW (TEFLON) TAPE

Insulates where slight movement is present. Ideal for instrument panel applications.

### SILICONE GREASE

Used in place of UHMW tape that is be visible or does not fit. Will only last a few months.

### SILICONE SPRAY

Used when grease cannot be applied.

### DUCT TAPE

Used to eliminate movement.

## CONFIRM THE REPAIR

Confirm that the cause of a noise is repaired by test driving the vehicle. Operate the vehicle under the same conditions as when the noise originally occurred. Refer to the notes on the Diagnostic Worksheet.

## Inspection Procedure

INFOID:000000004062136

Refer to Table of Contents for specific component removal and installation information.

## INSTRUMENT PANEL

Most incidents are caused by contact and movement between:

1. The cluster lid A and instrument panel
2. Acrylic lens and combination meter housing
3. Instrument panel to front pillar garnish
4. Instrument panel to windshield
5. Instrument panel mounting pins
6. Wiring harnesses behind the combination meter
7. A/C defroster duct and duct joint

These incidents can usually be located by tapping or moving the components to duplicate the noise or by pressing on the components while driving to stop the noise. Most of these incidents can be repaired by applying felt cloth tape or silicon spray (in hard to reach areas). Urethane pads can be used to insulate wiring harness.

### **CAUTION:**

**Never use silicone spray to isolate a squeak or rattle. If the area is saturated with silicone, the recheck of repair becomes impossible.**

## CENTER CONSOLE

Components to pay attention to include:

1. Shifter assembly cover to finisher
2. A/C control unit and cluster lid C
3. Wiring harnesses behind audio and A/C control unit

The instrument panel repair and isolation procedures also apply to the center console.

## DOORS

Pay attention to the following:

1. Finisher and inner panel making a slapping noise
2. Inside handle escutcheon to door finisher
3. Wiring harnesses tapping
4. Door striker out of alignment causing a popping noise on starts and stops

Tapping or moving the components or pressing on them while driving to duplicate the conditions can isolate many of these incidents. The areas can usually be insulated with felt cloth tape or insulator foam blocks from the Nissan Squeak and Rattle Kit (J-43980) to repair the noise.

## TRUNK

Trunk noises are often caused by a loose jack or loose items put into the trunk by the customer.

In addition look for the following:

1. Trunk lid dumpers out of adjustment
2. Trunk lid striker out of adjustment

# SQUEAK AND RATTLE TROUBLE DIAGNOSES

## < SYMPTOM DIAGNOSIS >

---

3. The trunk lid torsion bars knocking together

4. A loose license plate or bracket

Most of these incidents can be repaired by adjusting, securing or insulating the item(s) or component(s) causing the noise.

### SUNROOF/HEADLINING

Noises in the sunroof/headlining area can often be traced to one of the following:

1. Sunroof lid, rail, linkage or seals making a rattle or light knocking noise

2. Sunvisor shaft shaking in the holder

3. Front or rear windshield touching headlining and squeaking

Again, pressing on the components to stop the noise while duplicating the conditions can isolate most of these incidents. Repairs usually consist of insulating with felt cloth tape.

### SEATS

When isolating seat noise it's important to note the position the seats in and the load placed on the seat when the noise occurs. These conditions should be duplicated when verifying and isolating the cause of the noise.

Cause of seat noise include:

1. Headrest rods and holder

2. A squeak between the seat pad cushion and frame

3. The rear seatback lock and bracket

These noises can be isolated by moving or pressing on the suspected components while duplicating the conditions under which the noise occurs. Most of these incidents can be repaired by repositioning the component or applying urethane tape to the contact area.

### UNDERHOOD

Some interior noise may be caused by components under the hood or on the engine wall. The noise is then transmitted into the passenger compartment.

Causes of transmitted underhood noise include:

1. Any component mounted to the engine wall

2. Components that pass through the engine wall

3. Engine wall mounts and connectors

4. Loose radiator mounting pins

5. Hood bumpers out of adjustment

6. Hood striker out of adjustment

These noises can be difficult to isolate since they cannot be reached from the interior of the vehicle. The best method is to secure, move or insulate one component at a time and test drive the vehicle. Also, engine RPM or load can be changed to isolate the noise. Repairs can usually be made by moving, adjusting, securing, or insulating the component causing the noise.

A

B

C

D

E

F

G

H

I

INT

K

L

M

N

O

P

# SQUEAK AND RATTLE TROUBLE DIAGNOSES

< SYMPTOM DIAGNOSIS >

## Diagnostic Worksheet

INFOID:000000004062137



### SQUEAK & RATTLE DIAGNOSTIC WORKSHEET

Dear Infiniti Customer:

We are concerned about your satisfaction with your Infiniti vehicle. Repairing a squeak or rattle sometimes can be very difficult. To help us fix your Infiniti right the first time, please take a moment to note the area of the vehicle where the squeak or rattle occurs and under what conditions. You may be asked to take a test drive with a service consultant or technician to ensure we confirm the noise you are hearing.

#### I. WHERE DOES THE NOISE COME FROM? (circle the area of the vehicle)

The illustrations are for reference only, and may not reflect the actual configuration of your vehicle.

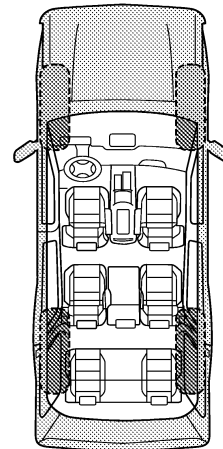
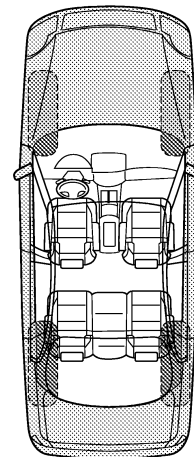

Continue to page 2 of the worksheet and briefly describe the location of the noise or rattle. In addition, please indicate the conditions which are present when the noise occurs.

PIIB8741E

# SQUEAK AND RATTLE TROUBLE DIAGNOSES

< SYMPTOM DIAGNOSIS >

## SQUEAK & RATTLE DIAGNOSTIC WORKSHEET - page 2

Briefly describe the location where the noise occurs:

---

---

### II. WHEN DOES IT OCCUR? (please check the boxes that apply)

- |   |  |
|---|--|
| <input type="checkbox"/> anytime                      | <input type="checkbox"/> after sitting out in the rain |
| <input type="checkbox"/> 1st time in the morning      | <input type="checkbox"/> when it is raining or wet     |
| <input type="checkbox"/> only when it is cold outside | <input type="checkbox"/> dry or dusty conditions       |
| <input type="checkbox"/> only when it is hot outside  | <input type="checkbox"/> other:                        |

### III. WHEN DRIVING:

- through driveways
- over rough roads
- over speed bumps
- only about \_\_\_\_ mph
- on acceleration
- coming to a stop
- on turns: left, right or either (circle)
- with passengers or cargo
- other: \_\_\_\_\_
- after driving \_\_\_\_ miles or \_\_\_\_ minutes

### IV. WHAT TYPE OF NOISE

- squeak (like tennis shoes on a clean floor)
- creak (like walking on an old wooden floor)
- rattle (like shaking a baby rattle)
- knock (like a knock at the door)
- tick (like a clock second hand)
- thump (heavy, muffled knock noise)
- buzz (like a bumble bee)

### TO BE COMPLETED BY DEALERSHIP PERSONNEL

#### Test Drive Notes:

---

---

---

	YES	NO	Initials of person performing
Vehicle test driven with customer	<input type="checkbox"/>	<input type="checkbox"/>	_____
- Noise verified on test drive	<input type="checkbox"/>	<input type="checkbox"/>	_____
- Noise source located and repaired	<input type="checkbox"/>	<input type="checkbox"/>	_____
- Follow up test drive performed to confirm repair	<input type="checkbox"/>	<input type="checkbox"/>	_____

VIN: \_\_\_\_\_ Customer Name: \_\_\_\_\_  
W.O.# \_\_\_\_\_ Date: \_\_\_\_\_

This form must be attached to Work Order

PIIB8742E

A  
B  
C  
D  
E  
F  
G  
H  
I  
INT  
K  
L  
M  
N  
O  
P

# PRECAUTIONS

< PRECAUTION >

## PRECAUTION

### PRECAUTIONS

#### Precaution for Supplemental Restraint System (SRS) "AIR BAG" and "SEAT BELT PRE-TENSIONER"

INFOID:000000005188794

The Supplemental Restraint System such as "AIR BAG" and "SEAT BELT PRE-TENSIONER", used along with a front seat belt, helps to reduce the risk or severity of injury to the driver and front passenger for certain types of collision. This system includes seat belt switch inputs and dual stage front air bag modules. The SRS system uses the seat belt switches to determine the front air bag deployment, and may only deploy one front air bag, depending on the severity of a collision and whether the front occupants are belted or unbelted. Information necessary to service the system safely is included in the "SRS AIR BAG" and "SEAT BELT" of this Service Manual.

#### **WARNING:**

- To avoid rendering the SRS inoperative, which could increase the risk of personal injury or death in the event of a collision which would result in air bag inflation, all maintenance must be performed by an authorized NISSAN/INFINITI dealer.
- Improper maintenance, including incorrect removal and installation of the SRS, can lead to personal injury caused by unintentional activation of the system. For removal of Spiral Cable and Air Bag Module, see the "SRS AIR BAG".
- Do not use electrical test equipment on any circuit related to the SRS unless instructed to in this Service Manual. SRS wiring harnesses can be identified by yellow and/or orange harnesses or harness connectors.

#### PRECAUTIONS WHEN USING POWER TOOLS (AIR OR ELECTRIC) AND HAMMERS

#### **WARNING:**

- When working near the Air Bag Diagnosis Sensor Unit or other Air Bag System sensors with the ignition ON or engine running, DO NOT use air or electric power tools or strike near the sensor(s) with a hammer. Heavy vibration could activate the sensor(s) and deploy the air bag(s), possibly causing serious injury.
- When using air or electric power tools or hammers, always switch the ignition OFF, disconnect the battery, and wait at least 3 minutes before performing any service.

#### Precaution Necessary for Steering Wheel Rotation after Battery Disconnect

INFOID:000000004172908

#### **NOTE:**

- Before removing and installing any control units, first turn the push-button ignition switch to the LOCK position, then disconnect both battery cables.
- After finishing work, confirm that all control unit connectors are connected properly, then re-connect both battery cables.
- Always use CONSULT-III to perform self-diagnosis as a part of each function inspection after finishing work. If a DTC is detected, perform trouble diagnosis according to self-diagnosis results.

This vehicle is equipped with a push-button ignition switch and a steering lock unit.

If the battery is disconnected or discharged, the steering wheel will lock and cannot be turned.

If turning the steering wheel is required with the battery disconnected or discharged, follow the procedure below before starting the repair operation.

#### OPERATION PROCEDURE

1. Connect both battery cables.

#### **NOTE:**

Supply power using jumper cables if battery is discharged.

2. Turn the push-button ignition switch to ACC position.  
(At this time, the steering lock will be released.)
3. Disconnect both battery cables. The steering lock will remain released with both battery cables disconnected and the steering wheel can be turned.
4. Perform the necessary repair operation.



# PRECAUTIONS

## < PRECAUTION >

5. When the repair work is completed, re-connect both battery cables. With the brake pedal released, turn the push-button ignition switch from ACC position to ON position, then to LOCK position. (The steering wheel will lock when the push-button ignition switch is turned to LOCK position.)
6. Perform self-diagnosis check of all control units using CONSULT-III.

### Precaution for Procedure without Cowl Top Cover

INFOID:000000004172909

When performing the procedure after removing cowl top cover, cover the lower end of windshield with urethane, etc.

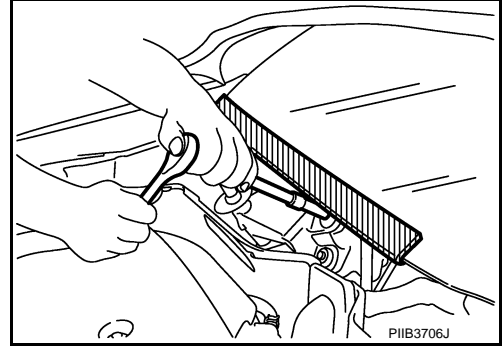

### Precaution for Work

INFOID:000000003854265

- After removing and installing the opening/closing parts, be sure to carry out fitting adjustments to check their operation.
- Check the lubrication level, damage, and wear of each part. If necessary, grease or replace it.

A  
B  
C  
D  
E  
F  
G  
H  
I  
K  
L  
M  
N  
O  
P

INT

# PREPARATION

< PREPARATION >

## PREPARATION

### PREPARATION

#### Special Service Tools

INFOID:000000003854266

The actual shapes of Kent-Moore tools may differ from those of special service tools illustrated here.

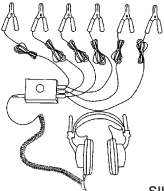
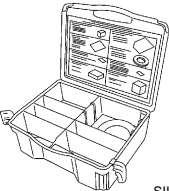
Tool number (Kent-Moore No.) Tool name	Description
(J-39570) Chassis ear   SIIA0993E	Locates the noise
(J-43980) NISSAN Squeak and Rattle Kit   SIIA0994E	Repairs the cause of noise

#### Commercial Service Tools

INFOID:000000003854267

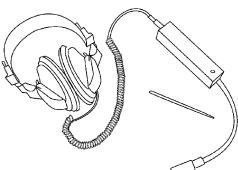
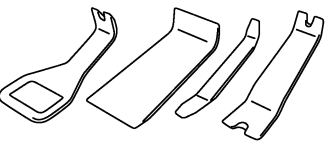
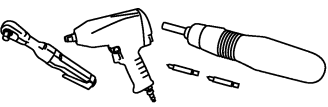
Tool name	Description
Engine ear   SIIA0995E	Locates the noise
Remover tool   PIIB7923J	Removes clips, pawls and metal clips
Power tool   PIIB1407E	

# FRONT DOOR FINISHER

< REMOVAL AND INSTALLATION >

## REMOVAL AND INSTALLATION

### FRONT DOOR FINISHER

Exploded View

INFOID:000000003854294

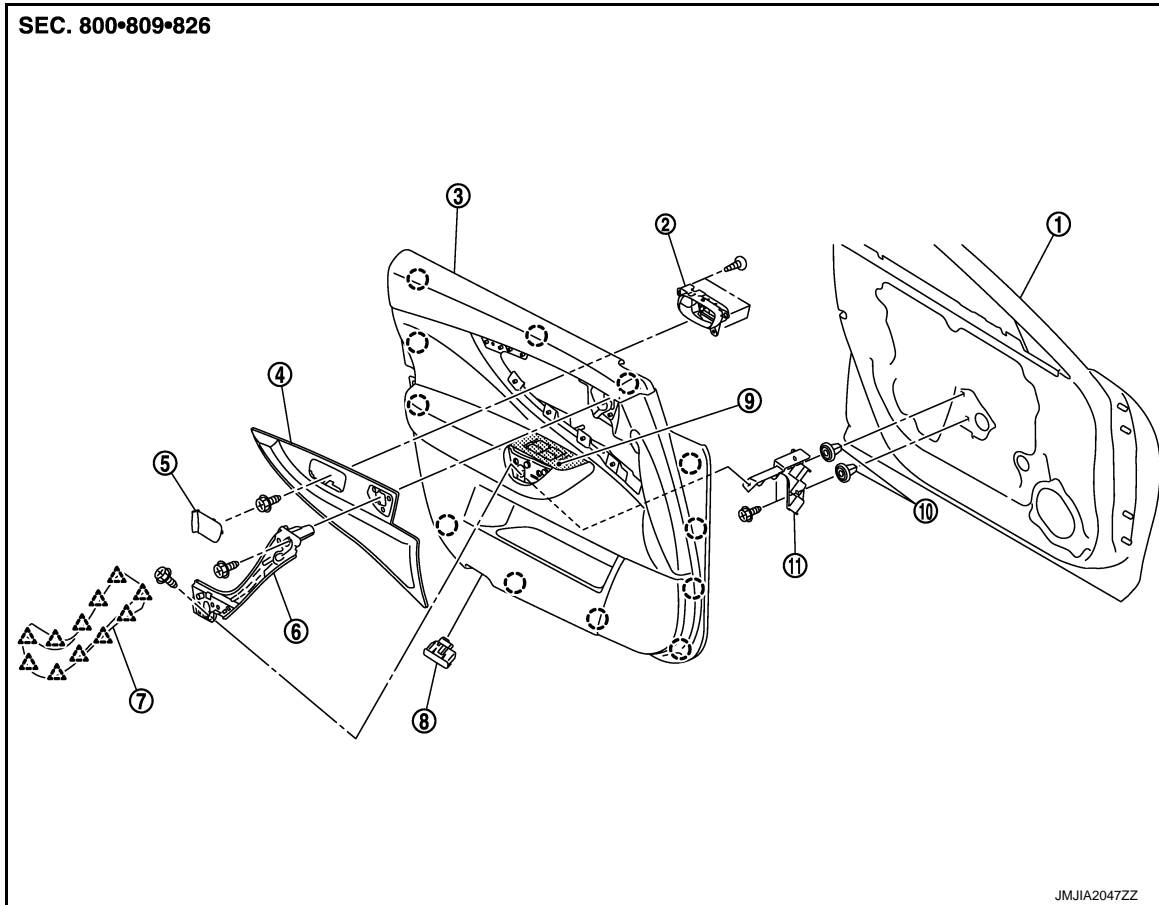

- |                               |                             |                                 |
|-------------------------------|-----------------------------|---------------------------------|
| 1. Front door panel           | 2. Front door inside handle | 3. Front door finisher          |
| 4. Front door center finisher | 5. Inside handle escutcheon | 6. Front door grip              |
| 7. Front door grip cap        | 8. Step lamp                | 9. Power window switch finisher |
| 10. Grommet                   | 11. Front door grip bracket |                                 |

- : Clip  
△ : Pawl

### Removal and Installation

INFOID:000000003854299

#### **CAUTION:**

**Wrap the tip of flat-bladed screwdriver with a cloth before remove.**

#### REMOVAL

1. Fully open door window.

# FRONT DOOR FINISHER

## < REMOVAL AND INSTALLATION >

2. Remove inside handle escutcheon (1) with a flat-bladed screwdriver (A) wrapped in a tape as shown in the figure.

 : Pawl

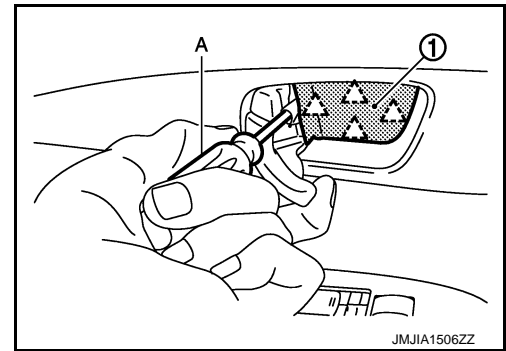

3. Insert a remover tool (A) between the front door grip cap (1) and the front door grip to disengage the pawls and remove the cap.

 : Pawl

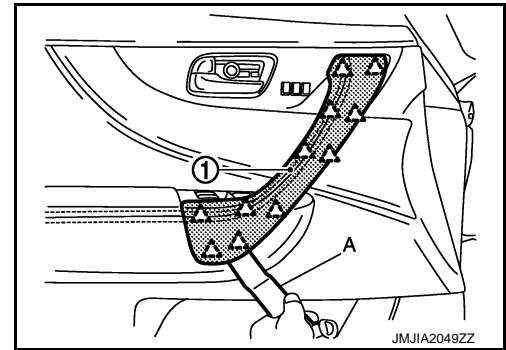

4. Remove the bolts shown by the arrows in the figure with an appropriate tool.

 : Bolt

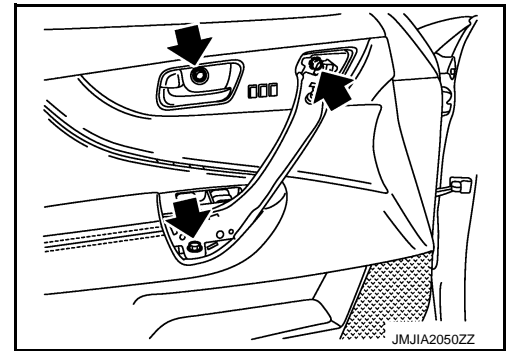

5. Remove the step lamp. Refer to [INL-178. "Removal and Installation"](#).  
6. Insert a remover tool (A) between the door finisher (1) and door panel to disengage the clips.

 : Clip

**CAUTION:**  
Insert a remover tool into the part shown in the figure.  
(Between the clips and the door panel)

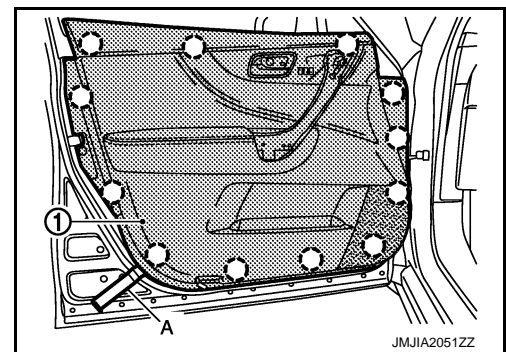

7. Disconnect lock knob cable (1), inside handle cable (2) and the seat memory switch harness connector (A).

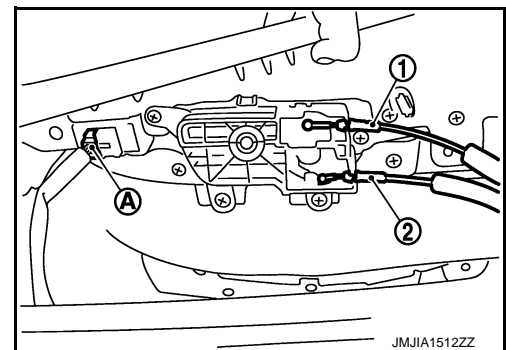

# FRONT DOOR FINISHER

## < REMOVAL AND INSTALLATION >

8. Disconnect the mood lamp harness connector. Refer to [INL-176, "FRONT DOOR ARMREST : Exploded View"](#).
9. Disconnect the power window switch finisher harness connectors.
10. Remove the front door finisher.

## INSTALLATION

Install in the reverse order of removal.

### **CAUTION:**

**When installing door finisher, check that clips are securely fitted in panel holes on body, and then press them in.**

## Disassembly and Assembly

INFOID:000000003940112

## DISASSEMBLY

1. Remove seat memory switch finisher. Refer to [ADP-209, "Removal and Installation"](#).
2. Remove front door inside handle. Refer to [DLK-259, "INSIDE HANDLE : Removal and Installation"](#).
3. Remove front door grip (1) fixing screws from front door finisher (2) and then remove it.

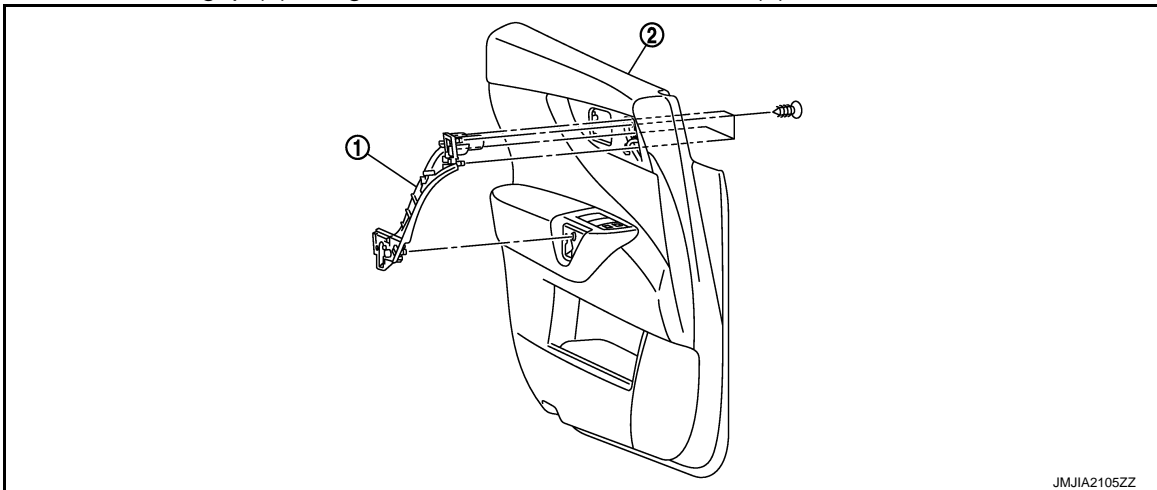

4. Remove front door center finisher (1) fixing screws from door finisher (2) and then remove it.

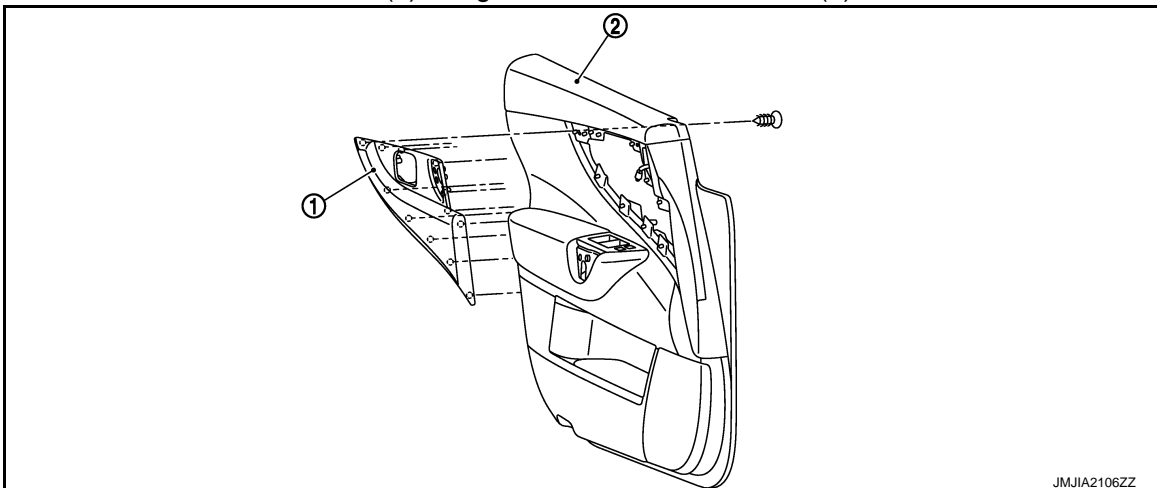

## ASSEMBLY

Assemble in the reverse order of removal.

A  
B  
C  
D  
E  
F  
G  
H  
I  
INT  
K  
L  
M  
N  
O  
P

# REAR DOOR FINISHER

< REMOVAL AND INSTALLATION >

## REAR DOOR FINISHER

Exploded View

INFOID:000000003854272

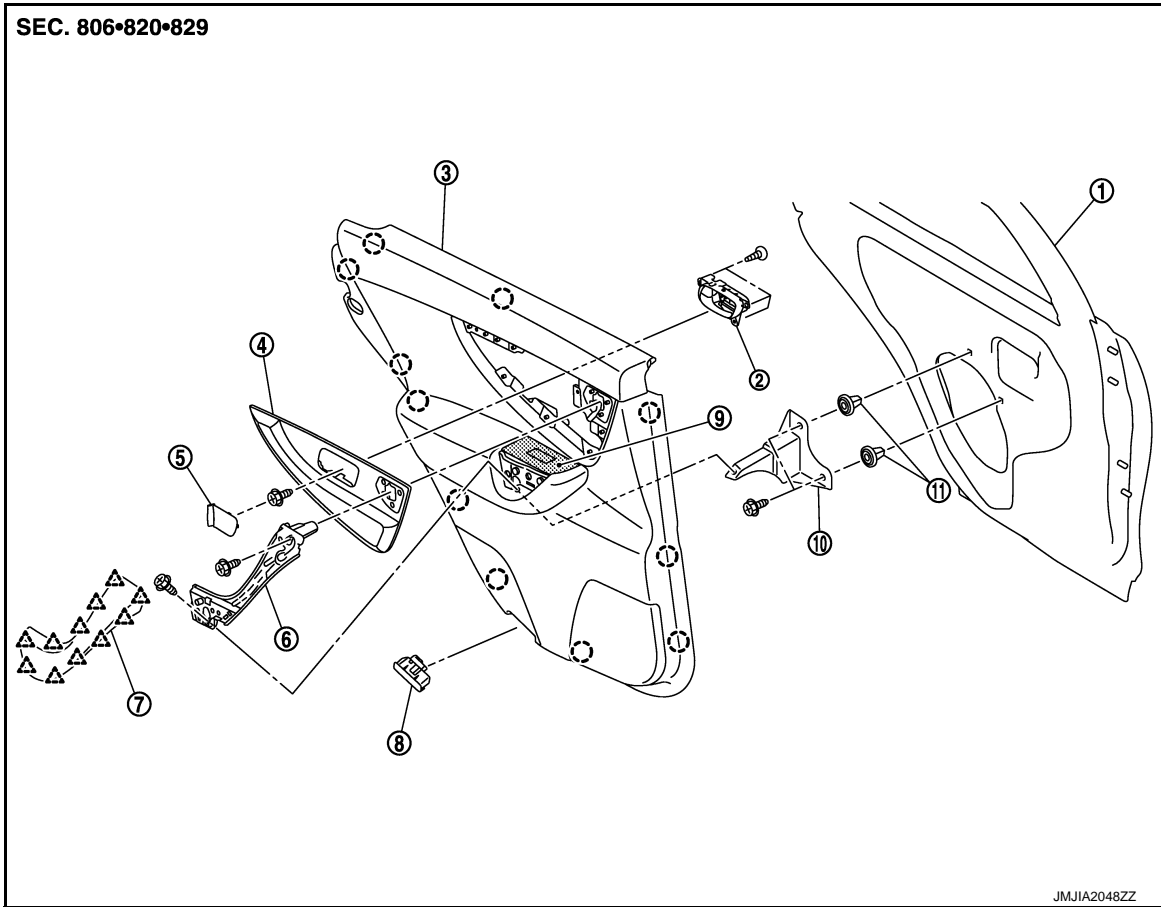

- |                              |                             |                                 |
|------------------------------|-----------------------------|---------------------------------|
| 1. Rear door panel           | 2. Rear door inside handle  | 3. Rear door finisher           |
| 4. Rear door center finisher | 5. Inside handle escutcheon | 6. Rear door grip               |
| 7. Rear door grip cap        | 8. Step lamp                | 9. Power window switch finisher |
| 10. Rear door grip bracket   | 11. Grommet                 |                                 |

- : Clip  
△ : Pawl

### Removal and Installation

INFOID:000000003854273

**CAUTION:**  
Wrap the tip of flat-bladed screwdriver with a cloth before remove.

#### REMOVAL

1. Fully open door window.

# REAR DOOR FINISHER

## < REMOVAL AND INSTALLATION >

2. Remove inside handle escutcheon (1) with a flat-bladed screwdriver (A) wrapped in a tape as shown in the figure.

 : Pawl

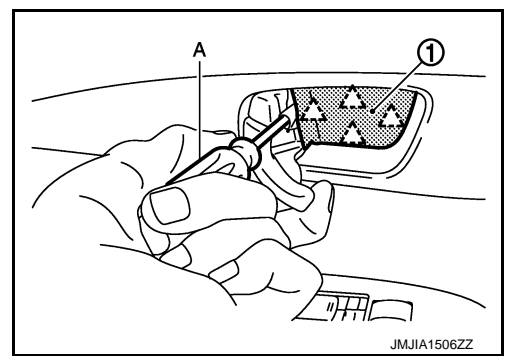

3. Insert a remover tool (A) between the rear door grip cap (1) and the rear door grip to disengage the pawls and remove the cap.

 : Pawl

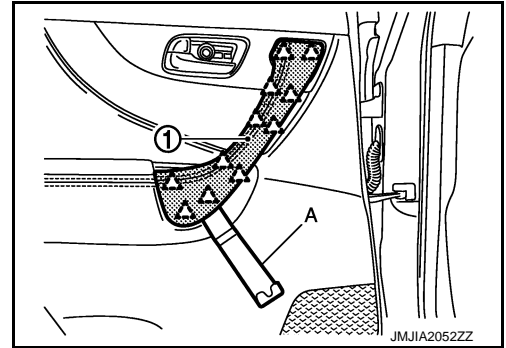

4. Remove the bolts shown by the arrows in the figure with an appropriate tool.

 : Bolt

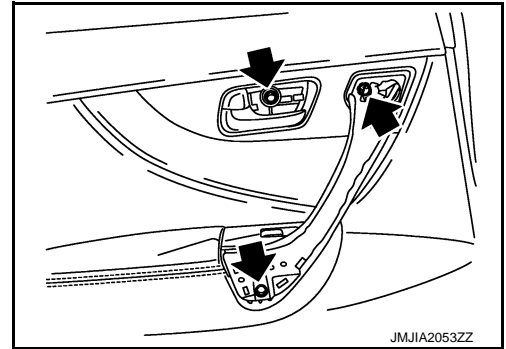

5. Remove the step lamp. Refer to [INL-178, "Removal and Installation"](#).
6. Insert a remover tool (A) between the door finisher (1) and door panel to disengage the clips.

 : Clip

**CAUTION:**  
Insert a remover tool into the part show in the figure.  
(Between the clips and the door panel)

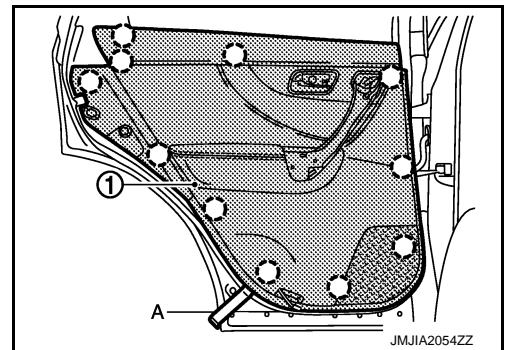

7. Disconnect lock knob cable (1) and inside handle cable (2) from rear inside handle (3).

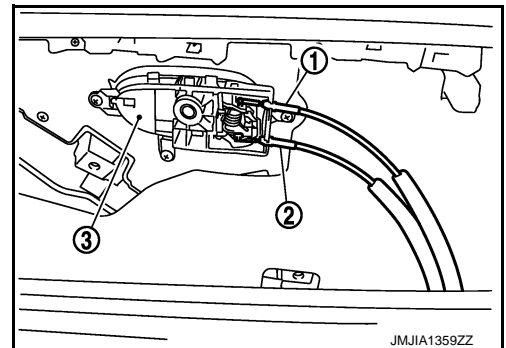

A  
B  
C  
D  
E  
F  
G  
H  
I  
INT  
K  
L  
M  
N  
O  
P

## REAR DOOR FINISHER

### < REMOVAL AND INSTALLATION >

---

8. Remove the mood lamp harness connector. Refer to [INL-176. "REAR DOOR ARMREST : Exploded View"](#).
9. Disconnect the rear door power window switch harness connector.
10. Remove the rear door finisher.

### INSTALLATION

Install in the reverse order of removal.

#### **CAUTION:**

**When installing door finisher, check that clips are securely fitted in panel holes on body, and then press them in.**

### Disassembly and Assembly

INFOID:000000003940131

### DISASSEMBLY

1. Remove the rear door grip and the rear door center finisher.

#### **NOTE:**

The procedure is same as for the front door finisher. Refer to [INT-13. "Disassembly and Assembly"](#).

2. Remove rear door inside handle. Refer to [DLK-263. "INSIDE HANDLE : Removal and Installation"](#).

### ASSEMBLY

Assemble in the reverse order of disassembly.



# BODY SIDE TRIM

< REMOVAL AND INSTALLATION >

## BODY SIDE TRIM

Exploded View

INFOID:000000003854274

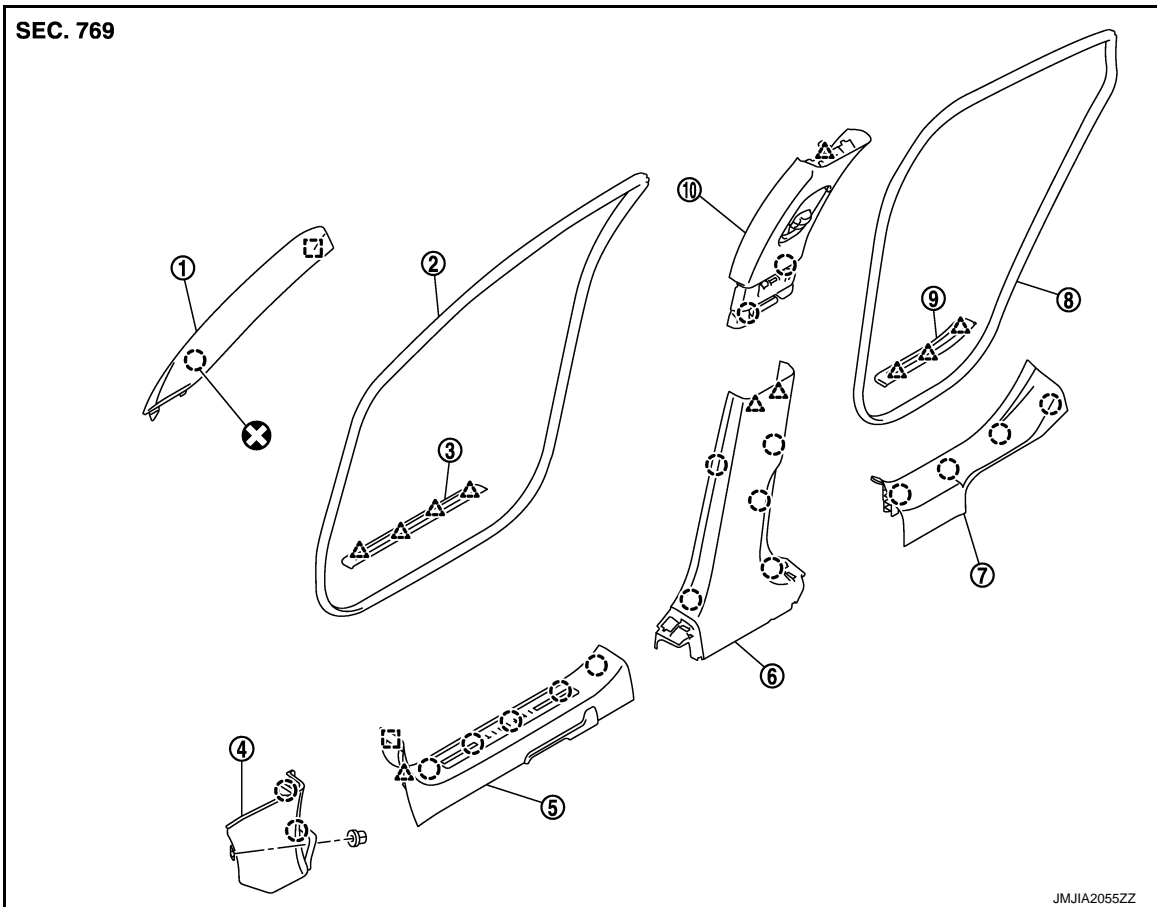

- |                                 |                                |                                |
|---------------------------------|--------------------------------|--------------------------------|
| 1. Front pillar garnish         | 2. Front body side welt        | 3. Front kicking plate (outer) |
| 4. Dash side finisher           | 5. Front kicking plate (inner) | 6. Center pillar lower garnish |
| 7. Rear kicking plate (inner)   | 8. Rear body side welt         | 9. Rear kicking plate (outer)  |
| 10. Center pillar upper garnish |                                |                                |

○ : Clip

△ : Pawl

□ : Metal clip

Refer to [GI-4, "Components"](#) for symbols in the figure.

### Removal and Installation

INFOID:000000003854275

#### **CAUTION:**

**Wrap the tip of flat-bladed screwdriver with a shop cloth when removing metal clips from garnishes.**

#### REMOVAL

##### FRONT PILLAR GARNISH



1. Remove front body side welt partially.

A  
B  
C  
D  
E  
F  
G  
H  
I  
INT  
K  
L  
M  
N  
O  
P

# BODY SIDE TRIM

## < REMOVAL AND INSTALLATION >

- Disengage front pillar garnish (1) mounting clip and metal clip with remover tool (A).
- Pull the front pillar garnish partially toward the vehicle.

-  : Clip
-  : Metal clip

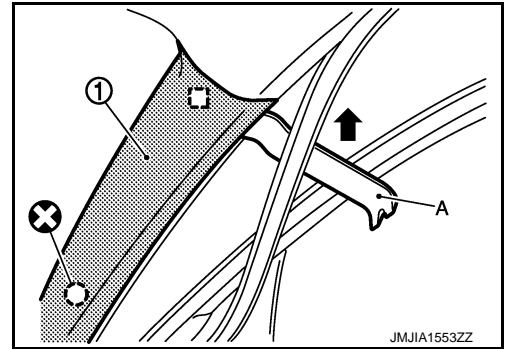

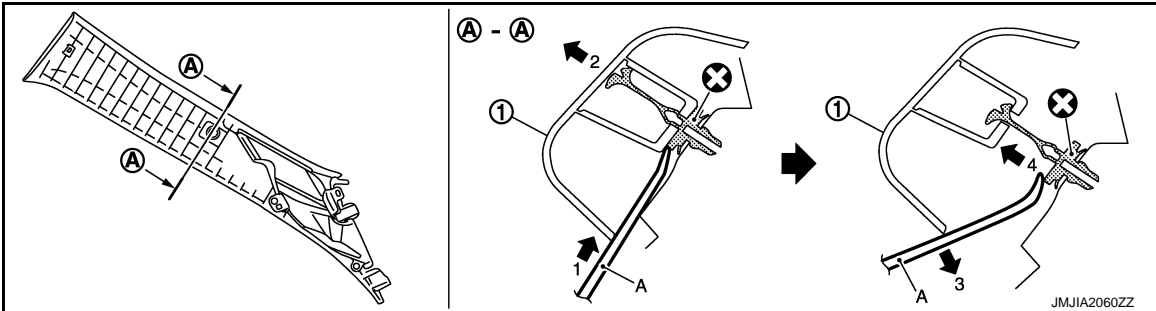

- Insert the remover tool (A) between mounting clip bottom side and body side to disengage front pillar garnish (1) mounting clip and then cut the clip with a cutter tool.



- Once free, pull front pillar garnish (1) upwards to disengage the lower locating tab from instrument panel.
- Remove front pillar garnish.

## FRONT KICKING PLATE INNER

- Disengage the clips from the body side panel with a remover tool (A).
- Remove front kicking plate inner (1).

-  : Clip
-  : Pawl
-  : Metal clip

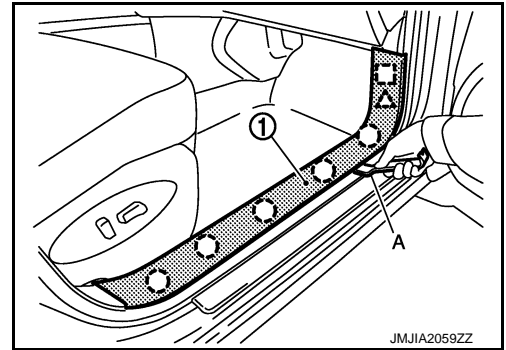

## FRONT KICKING PLATE OUTER

- Disengage the pawls from the body side panel with remover tool (A).
- Remove front kicking plate outer (1)

-  : Pawl

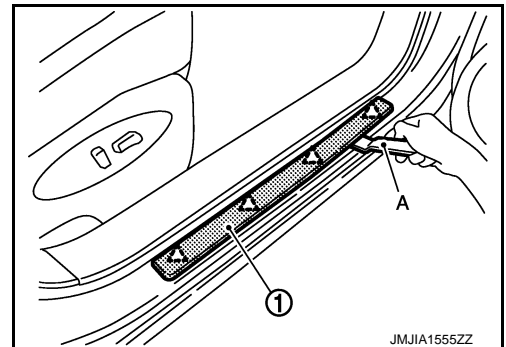

## DASH SIDE FINISHER

- Remove front kicking plate inner.

# BODY SIDE TRIM

## < REMOVAL AND INSTALLATION >

2. Remove clip (A).
3. Disengage dash side finisher (1) mounting clips with a remover tool (B).
4. Remove dash side finisher.

 : Clip

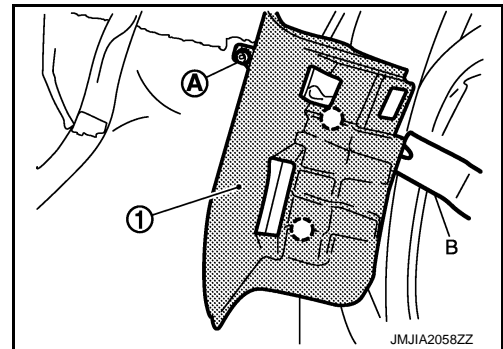

### REAR KICKING PLATE INNER

1. Disengage the clips from the body with remover tool (A).
2. Remove rear kicking plate inner (1).

 : Clip

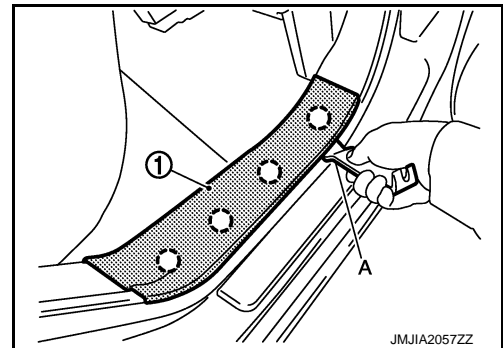

### REAR KICKING PLATE OUTER

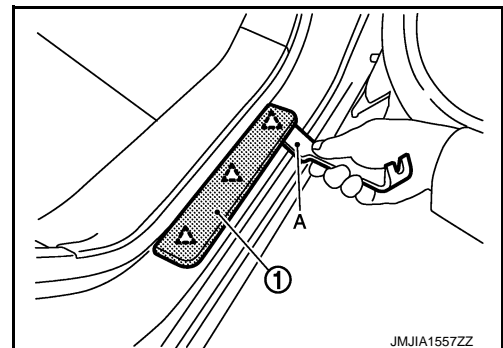

1. Disengage the pawls from the body side panel with remover tool (A).
2. Remove rear kicking plate outer (1).

 : Pawl



### CENTER PILLAR LOWER GARNISH

1. Remove front and rear kicking plate inner.
2. Insert a remover tool (A) between center pillar lower garnish (1) and body side panel to disengage the clips and pawls.
3. Remove center pillar lower garnish.

 : Clip  
 : Pawl

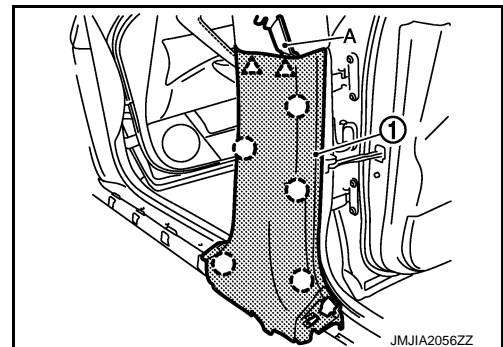

### CENTER PILLAR UPPER GARNISH

1. Remove the front seat belt anchor floor bolt. Refer to [SB-8, "SEAT BELT BUCKLE : Exploded View"](#).
2. Remove front and rear kicking plate inner.
3. Remove center pillar lower garnish.
4. Remove center pillar upper garnish lower clip.

A  
B  
C  
D  
E  
F  
G  
H  
I  
INT  
K  
L  
M  
N  
O  
P

## BODY SIDE TRIM

### < REMOVAL AND INSTALLATION >

5. Hold the upper side of center pillar upper garnish (1), then remove it as shown in the figure below.

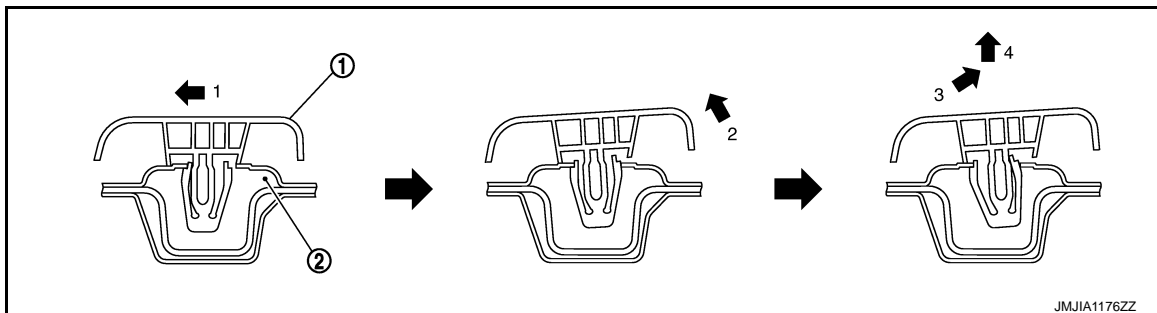

1. Center pillar upper garnish

2. Center pillar panel

### INSTALLATION

Install in the reverse order of removal.

#### **CAUTION:**

**When installing body side trim, check that clips are securely fitted in panel holes on body, and then press them in.**

# FLOOR TRIM

< REMOVAL AND INSTALLATION >

## FLOOR TRIM

Exploded View

INFOID:000000003854276

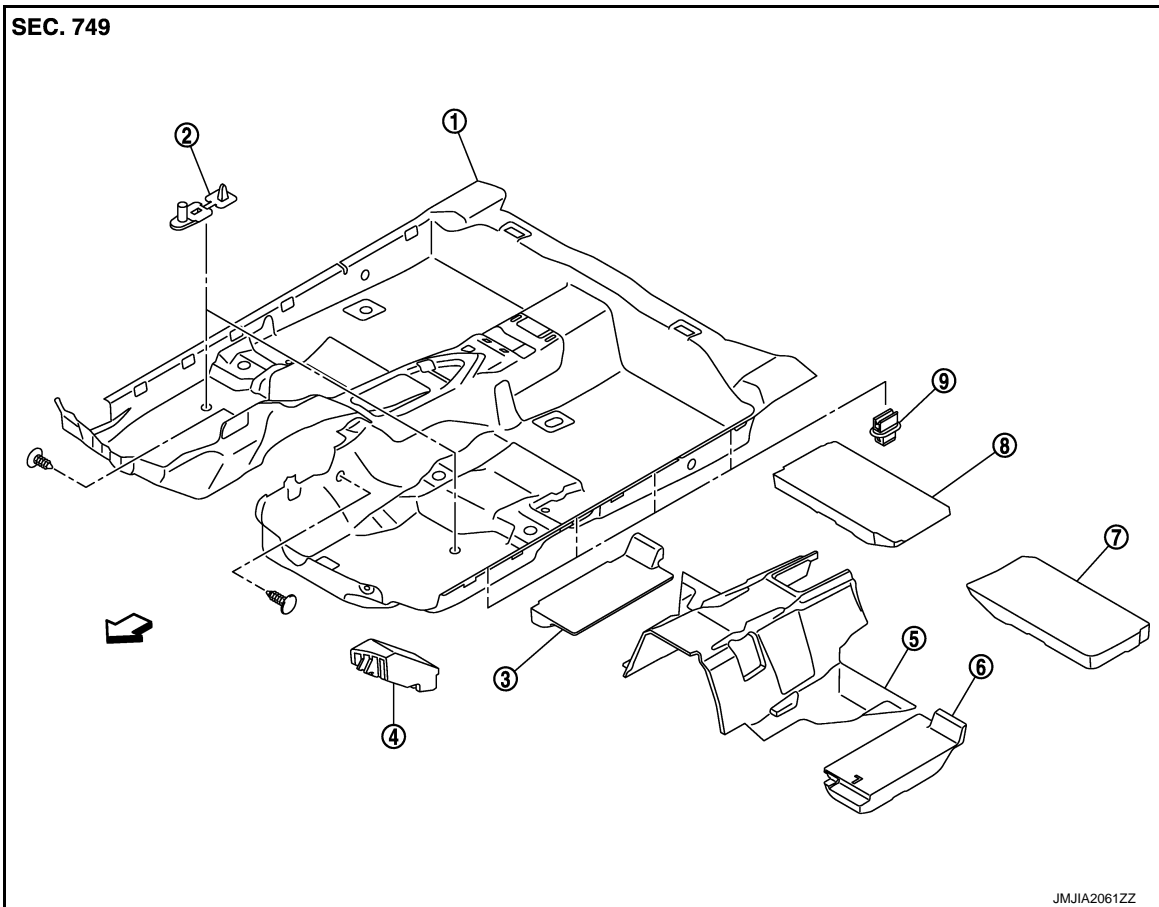

- |                           |                              |                            |
|---------------------------|------------------------------|----------------------------|
| 1. Floor trim             | 2. Floor hook                | 3. Front floor spacer (RH) |
| 4. Footrest               | 5. Front floor spacer center | 6. Front floor spacer (LH) |
| 7. Rear floor spacer (LH) | 8. Rear floor spacer (RH)    | 9. Fixing clip             |

↔ : Vehicle front

## Removal and Installation

INFOID:000000003854277

### REMOVAL

1. Remove front seatback and seat cushion (LH/RH). Refer to [SE-73, "Removal and Installation"](#).
2. Remove rear seat cushion. Refer to [SE-83, "Removal and Installation"](#).
3. Remove accelerator pedal pad. Refer to [ACC-4, "MODELS WITH DISTANCE CONTROL ASSIST SYSTEM : Removal and Installation"](#).
4. Disengage clip of floor hook (1) with remover tool (A).

○ : Clip

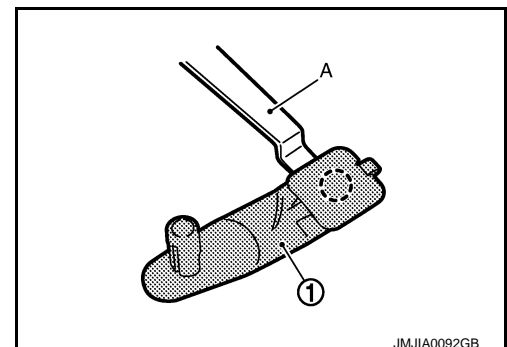

JMJA0092GB

## FLOOR TRIM

### < REMOVAL AND INSTALLATION >

5. Remove foot grille (LH/RH). Refer to [VTL-17, "FOOT GRILLE : Removal and Installation"](#).
6. Remove front seat belt floor anchor bolt (LH/RH). Refer to [SB-8, "SEAT BELT BUCKLE : Exploded View"](#).
7. Remove center console assembly. Refer to [IP-22, "Removal and Installation"](#).
8. Remove rear floor duct 1. Refer to [VTL-19, "REAR FLOOR DUCT 1 : Removal and Installation"](#).
9. Remove instrument lower cover (LH/RH), instrument lower panel (LH/RH) and instrument side finisher (LH/RH). Refer to [IP-12, "Removal and Installation"](#).
10. Remove yaw rate/side G sensor. Refer to [BRC-138, "Removal and Installation"](#).
11. Remove diagnosis sensor unit. Refer to [SR-19, "Removal and Installation"](#).
12. Remove console rear bracket. Refer to [IP-22, "Removal and Installation"](#).
13. Remove floor harness mounting clamps.
14. Remove dash side finisher (LH/RH), front and rear kicking plate inner (LH/RH) and center pillar lower garnish (LH/RH). Refer to [INT-17, "Removal and Installation"](#).
15. Remove floor trim mounting clips and fixing nuts.
16. Remove floor trim from floor trim fixing clips (A) and remove floor trim.

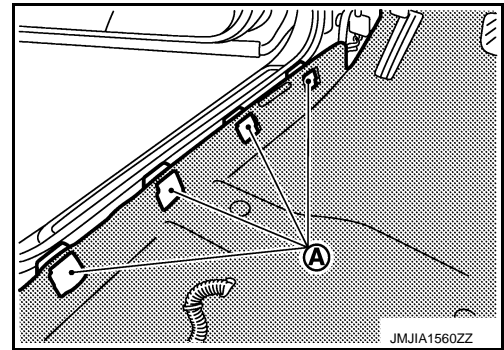

### INSTALLATION

Install in the reverse order of removal.

# HEADLINING

< REMOVAL AND INSTALLATION >

## HEADLINING

Exploded View

INFOID:000000003854280

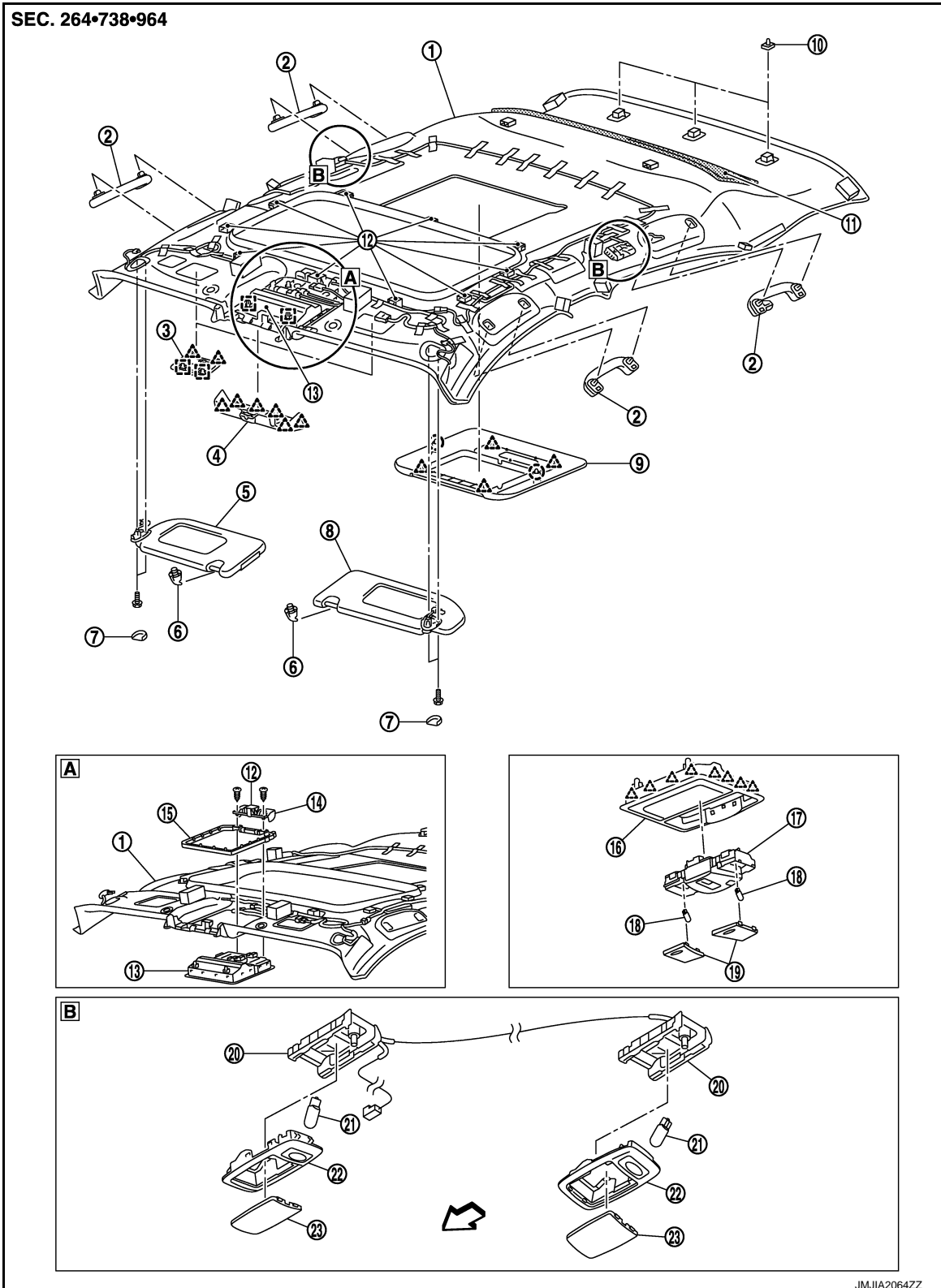

- |                        |                            |                          |
|------------------------|----------------------------|--------------------------|
| 1. Headlining assembly | 2. Assist grip             | 3. Front roof finisher   |
| 4. Lane camera cover   | 5. Sun-visor assembly (RH) | 6. Sun-visor holder      |
| 7. Sun-visor cap       | 8. Sun-visor assembly (LH) | 9. Rear monitor assembly |

# HEADLINING

## < REMOVAL AND INSTALLATION >

- |                                    |                                   |                                |
|------------------------------------|-----------------------------------|--------------------------------|
| 10. Rear hidden clip               | 11. Roof insulator                | 12. Dual lock fastener         |
| 13. Roof console assembly          | 14. Roof console bracket          | 15. Sunroof module plate       |
| 16. Roof console                   | 17. Map lamp assembly             | 18. Map lamp bulb (LH/RH)      |
| 19. Map lamp lens (LH/RH)          | 20. Personal lamp bracket (LH/RH) | 21. Personal lamp bulb (LH/RH) |
| 22. Personal lamp finisher (LH/RH) | 23. Personal lamp lens (LH/RH)    |                                |

○ : Clip

△ : Pawl

□ : Metal clip

← : Vehicle front

## Removal and Installation

INFOID:000000003854281

### REMOVAL

1. Remove the rear seat cushion. Refer to [SE-83. "Removal and Installation"](#).
2. Remove the rear seatback. Refer to [SE-83. "Removal and Installation"](#).
3. Remove front seat belt anchor bolt (LH/RH). Refer to [SB-8. "SEAT BELT BUCKLE : Exploded View"](#).
4. Remove rear seat belt anchor bolt (LH/RH). Refer to [SB-15. "SEAT BELT BUCKLE : Exploded View"](#).
5. Remove front pillar garnish (LH/RH), front kicking plate inner (LH/RH), center pillar lower garnish (LH/RH), center pillar upper garnish (LH/RH), front body side welt (LH/RH), rear body side welt (LH/RH), rear kicking plate inner (LH/RH). Refer to [INT-17. "Removal and Installation"](#).
6. Remove luggage side lower finisher (LH/RH), luggage side upper finisher (LH/RH). Refer to [INT-29. "Removal and Installation"](#).
7. Remove the sun-visor (LH).
  - Remove sun-visor cap.
  - Remove mounting screws.
  - Disconnect vanity mirror lamp harness connector (with vanity mirror lamp)
8. With a remover tool, disengage the driver side front roof finisher (1) fixing pawls and metal clips, disconnect the harness connector (A) and then remove the front roof finisher.

△ : Pawl

□ : Metal clip

← : Vehicle front

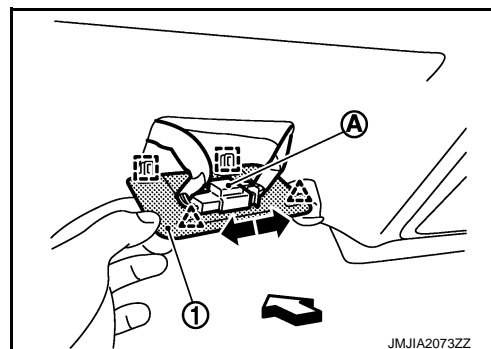

JMJIA2073ZZ

9. Remove the lane camera cover mounting pawls with a remover tool (A), then remove the lane camera cover (1).

△ : Pawl

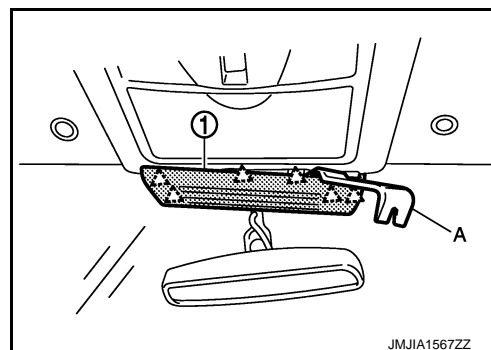

JMJIA1567ZZ

10. Disconnect inside mirror harness connectors.
11. Remove the sun-visor (RH).
  - Remove sun-visor cap.
  - Remove mounting screws.
  - Disconnect vanity mirror lamp harness connector (with vanity mirror lamp)



# HEADLINING

## < REMOVAL AND INSTALLATION >

12. Remove the passenger side front roof finisher mounting pawls and metal clips with a remover tool (A), then remove the front roof finisher (1).

- △ : Pawl  
□ : Metal clip

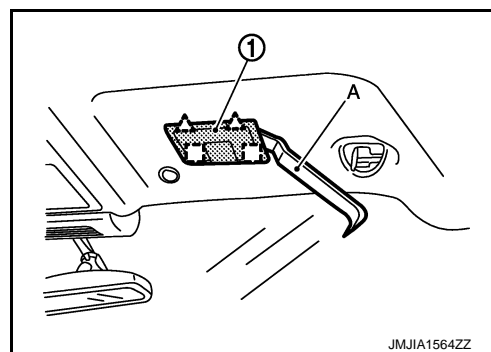

13. Remove assist grips.
- With a small flat-bladed screwdriver (A), press the upper side mounting assist grip cap (1) and pull up to remove the mounting assist grip cap from assist grip (2).

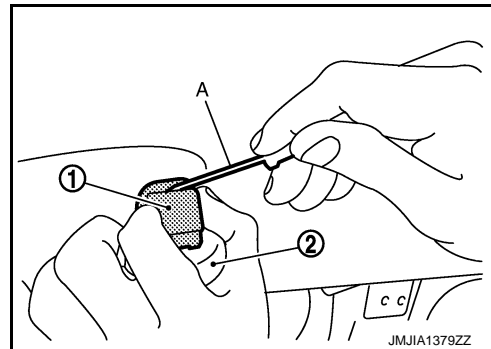

- Once the mounting assist grip cap (1) is removed, pull out the assist grip (2) to remove.

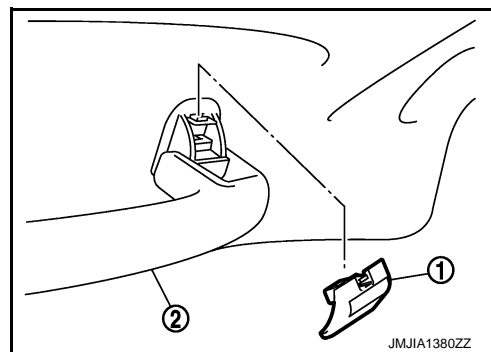

14. Disengage the rear monitor finisher fixing clips and pawls with a remover tool (A), disconnect the harness and then remove the rear monitor finisher (1). (With rear monitor assembly only)

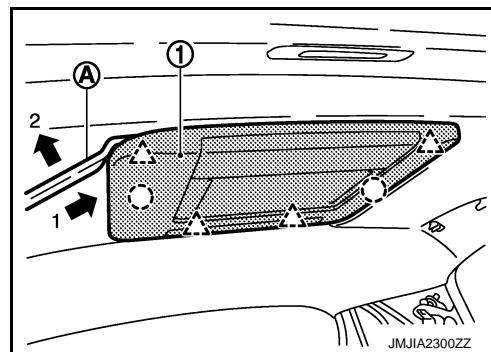

A  
B  
C  
D  
E  
F  
G  
H  
I  
INT  
K  
L  
M  
N  
O  
P

# HEADLINING

## < REMOVAL AND INSTALLATION >

15. Insert a small flat-bladed screwdriver (A) into the hole of the sun-visor holder (1), press while rotating approximately 90 degrees to remove.

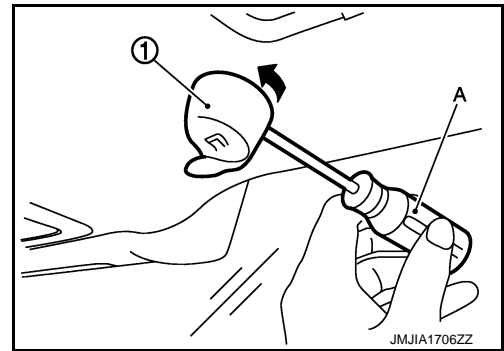

16. Using remover tool, remove headlining hidden clip at the back side of headlining.  
17. Pull down roof console assembly and disengage metal clips (B) and dual-lock fastener (A).

**CAUTION:**

Roof console assembly is crimped from the back of headlining. Remove it by disengaging the crimped area of back of roof console assembly after removing headlining from the vehicle.

 : Metal clip

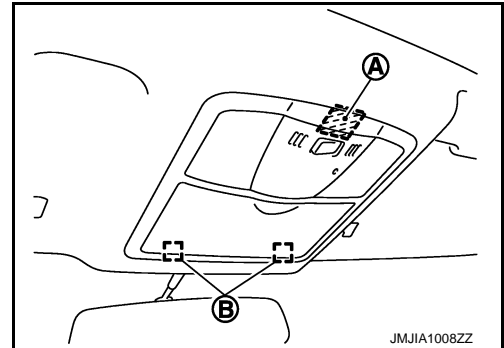

18. Remove headlining (1) from back door.

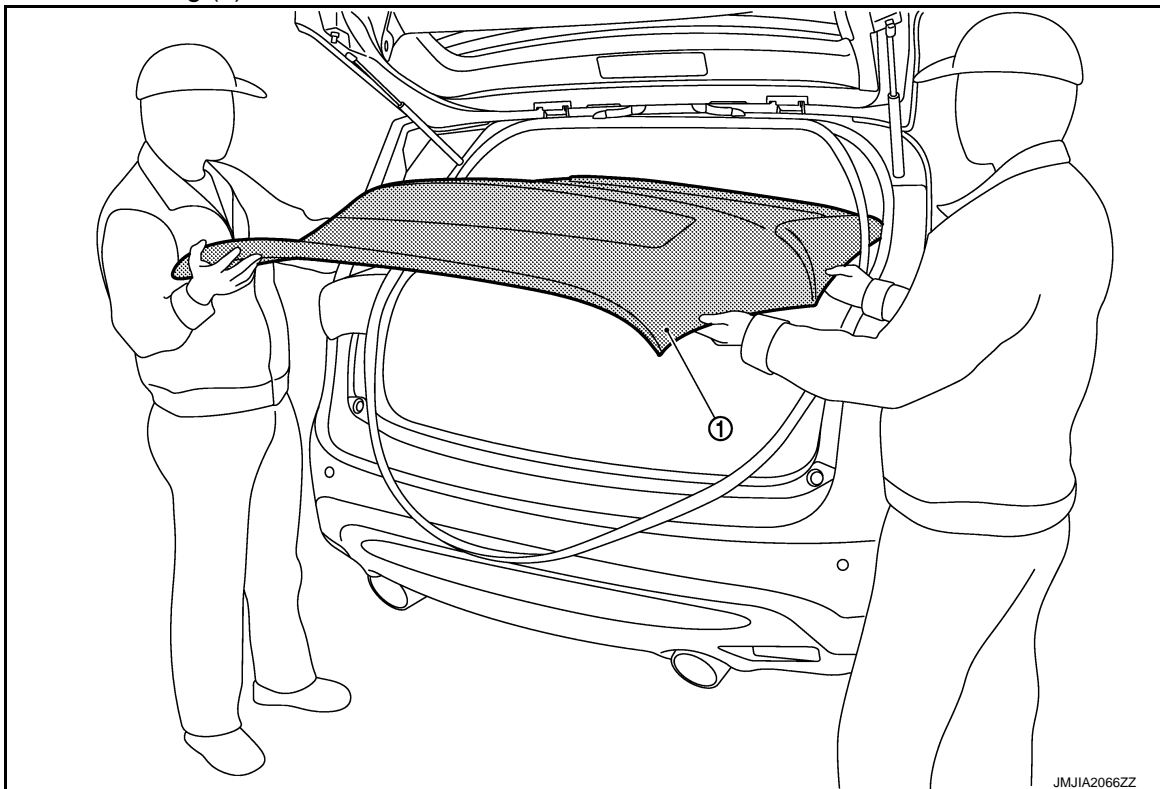

**CAUTION:**

- When removing, 2 workers are required.
- Never bend headlining when removing.
- Be careful not to scratch or damage any part of the body while taking out the headlining.

19. Remove the following parts after removing headlining.
- Roof console assembly. Refer to [INT-23, "Exploded View"](#).
  - Map lamp assembly. Refer to [INL-169, "Removal and Installation"](#).
  - Personal lamp assembly. Refer to [INL-179, "Removal and Installation"](#).

# HEADLINING

## < REMOVAL AND INSTALLATION >

---

- Headlining harness.

### INSTALLATION

Install in the reverse order of removal.

#### **CAUTION:**

- **As for guide, install first sun-visor holder (LH/RH) and then the rear hidden clips at the back side of headlining.**
- **Be careful not to bend the headlining when installing.**

A

B

C

D

E

F

G

H

I

INT

K

L

M

N

O

P

# LUGGAGE FLOOR TRIM

< REMOVAL AND INSTALLATION >

## LUGGAGE FLOOR TRIM

Exploded View

INFOID:000000003854282

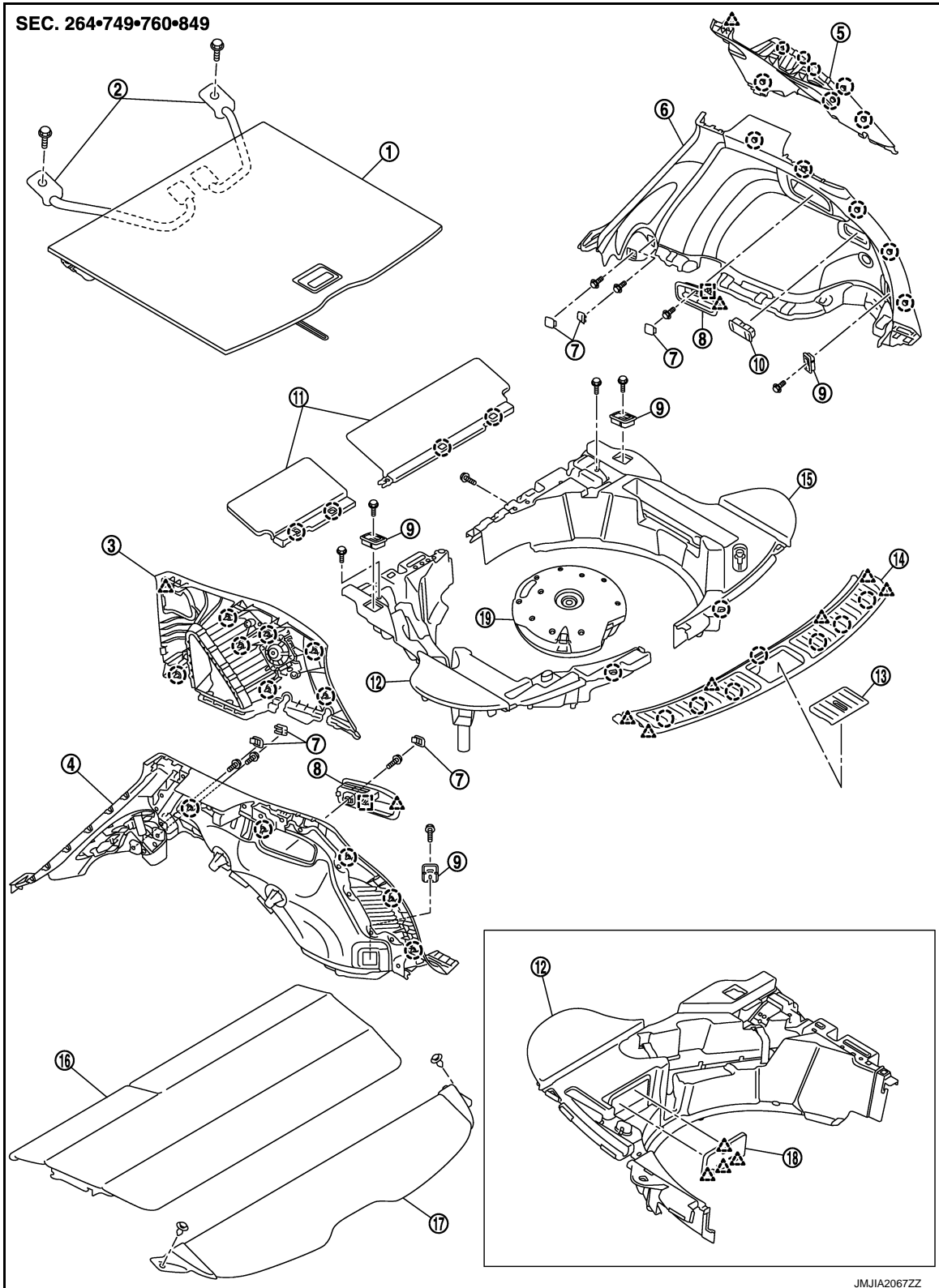

- |                                     |                                     |                                     |
|-------------------------------------|-------------------------------------|-------------------------------------|
| 1. Luggage finisher center          | 2. Belt assembly                    | 3. Luggage side finisher upper (LH) |
| 4. Luggage side finisher lower (LH) | 5. Luggage side finisher upper (RH) | 6. Luggage side finisher lower (RH) |
| 7. Seatback control finisher cap    | 8. Seatback control cable finisher  | 9. Rope hook                        |

JMJIA2067ZZ

# LUGGAGE FLOOR TRIM

## < REMOVAL AND INSTALLATION >

- |                            |   |                               |
|----------------------------|---|-------------------------------|
| 10. Luggage room lamp      | 11. Luggage floor finisher front        | 12. Luggage floor spacer (LH) |
| 13. Luggage rear plate cap | 14. Luggage rear plate                  | 15. Luggage floor spacer (RH) |
| 16. Tonneau cover assembly | 17. Tonneau cover (Back door trim side) | 18. Luggage side finisher lid |
| 19. Bose woofer            |   |                               |

 : Clip

 : Pawl

 : Metal clip

## Removal and Installation

INFOID:000000003854283

### REMOVAL

#### LUGGAGE REAR PLATE

1. Fully open back door.
2. Remove tonneau cover assembly.
3. Open and pull luggage finisher center (1) backwards, till the bolts are visible.
4. Remove both bolts and then remove luggage finisher center.

 : Bolt

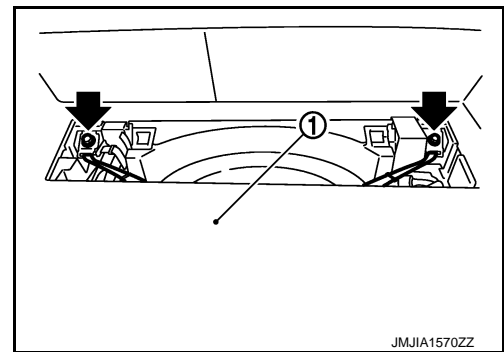

5. Remove the clip (A), disconnect the woofer harness connector (B), and then remove the woofer (1) and spire tire (2). Refer to [AV-1055, "Removal and Installation"](#).

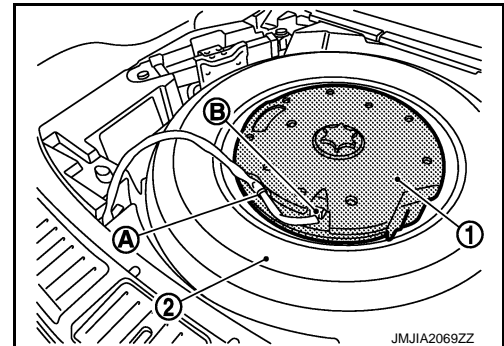

6. Remove the rear seat assembly. Refer to [SE-83, "Removal and Installation"](#).
7. Remove the luggage floor finisher front (LH/RH).
8. Remove back door weather-strip.
9. Disengage the rear plate (1) fixing clips with a remover tool (A) then remove it.
10. Hold both sides of luggage rear plate, pull upwards to remove.

 : Clip

 : Pawl

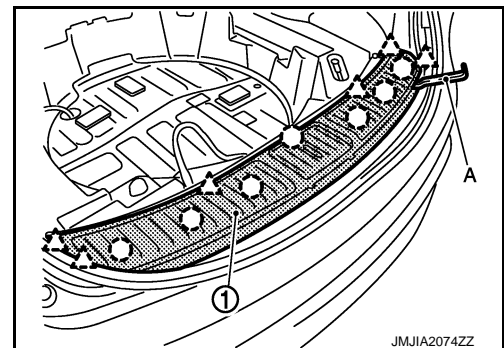



#### LUGGAGE FLOOR SPACER

# LUGGAGE FLOOR TRIM

## < REMOVAL AND INSTALLATION >

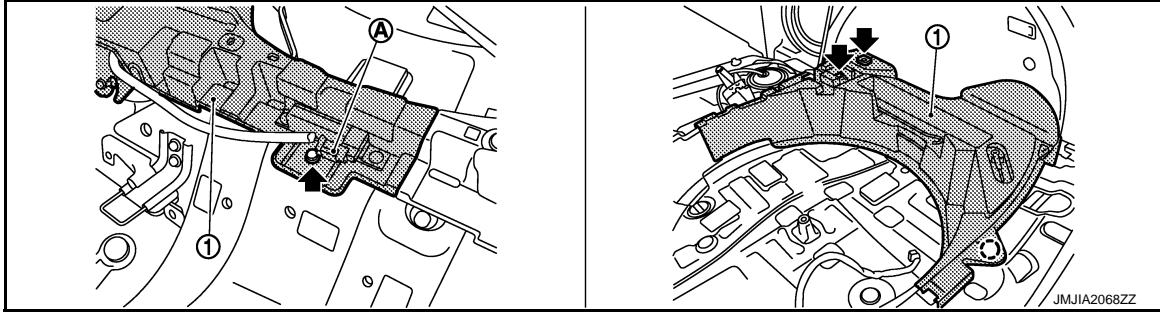
1. Disconnect the harness connector (A), remove the bolts shown by the arrows in the figure below, then remove the luggage floor spacer (1) (RH/LH).



 : Clip



2. Remove the bolts located inside the luggage floor spacer and then remove luggage floor spacer. (RH/LH)

### LUGGAGE SIDE FINISHER LOWER

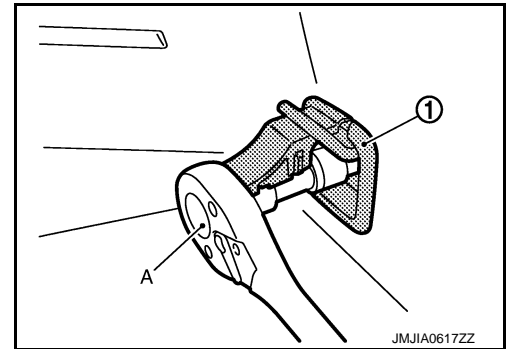
1. Remove rear kicking plate inner and rear body side welt. Refer to [INT-17. "Removal and Installation"](#).
2. Remove rear seat assembly fixing bolts. Refer to [SB-15. "SEAT BELT BUCKLE : Exploded View"](#).
3. Remove luggage rear plate.
4. Remove luggage floor spacers (LH/RH).
5. Disengage rope hook mounting bolt caps, and remove rope hook mounting bolts with socket wrench (A), and then remove rope hooks (1) (LH/RH).



6. Remove seatback control cable finisher (1) fixing bolt (A), then remove the seatback control cable finisher (LH/RH).

 : Pawl  
 : Metal clip

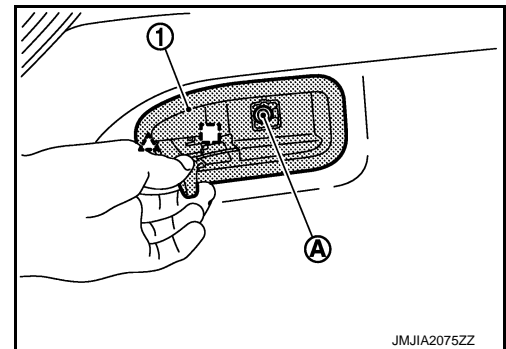

7. Remove the luggage room lamp (RH). Refer to [INL-182. "LUGGAGE SIDE : Removal and Installation"](#).
8. Remove luggage side finisher lower fixing clips with remover tool.

# LUGGAGE FLOOR TRIM

## < REMOVAL AND INSTALLATION >

9. Pull the luggage side finisher lower (1) to disengage the clips and metal clips, then disconnect the luggage room power socket harness connector (A).

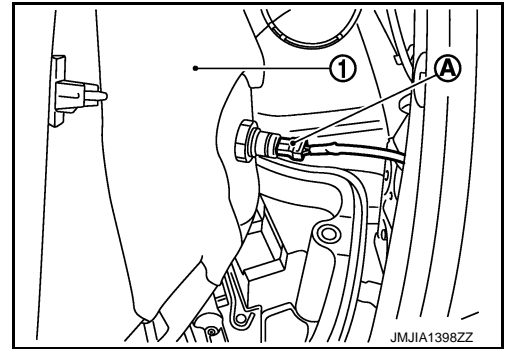

10. Remove luggage side finisher lower.

### LUGGAGE SIDE FINISHER UPPER

1. Remove rear seat belt floor anchor bolt.
2. Remove luggage side finisher lower.
3. Remove the rear seat belt finisher.
4. Remove luggage side upper finisher clips and pawl with remover tool (A).

- : Clip
- △ : Pawl

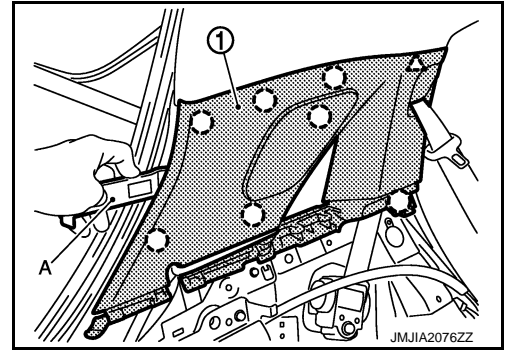

5. Disconnect the rear squawker harness connector and then remove the rear squawker. Refer to [AV-1053](#), "[Removal and Installation](#)".
6. Remove luggage side finisher upper (1) from the body side panel.

### INSTALLATION

Install in the reverse order of removal.

#### **CAUTION:**

**Check that clips, pawls, metal clips are securely fitted in panel holes on body when installing, and then press them in.**

A  
B  
C  
D  
E  
F  
G  
H  
I  
INT  
K  
L  
M  
N  
O  
P

# BACK DOOR TRIM

< REMOVAL AND INSTALLATION >

## BACK DOOR TRIM

Exploded View

INFOID:000000003854284

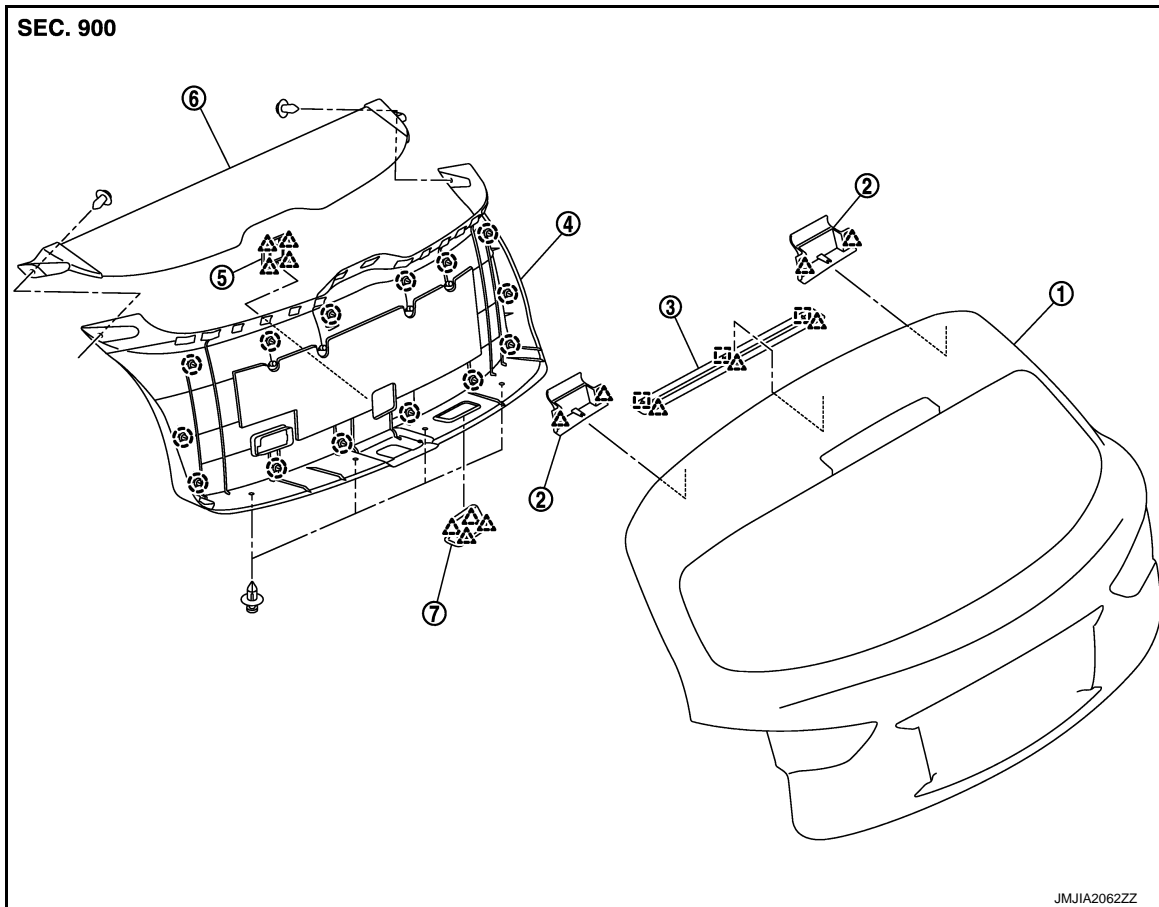

- |                             |                           |  |
|-----------------------------|---------------------------|--|
| 1. Back door assembly       | 2. Back door hinge cover  | 3. Back door plate                     |
| 4. Back door finisher inner | 5. Back door finisher lid | 6. Tonneau cover (Back door trim side) |
| 7. Pull handle finisher     |                           |  |

- : Clip  
△ : Pawl

## Removal and Installation

INFOID:000000003854285

### REMOVAL

#### BACK DOOR FINISHER INNER

1. Fully open back door.
2. Disengage the clips fixing the tonneau cover assembly (1) to the back door panel with a remover tool (A), then remove the tonneau cover assembly.

- : Clip

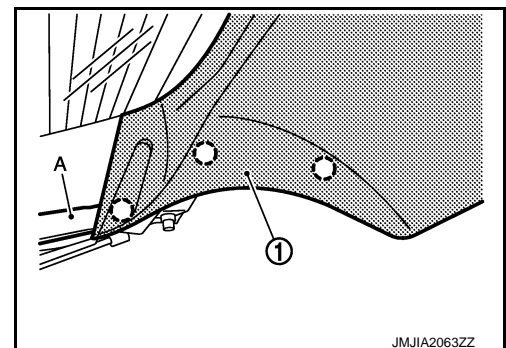





# BACK DOOR TRIM

## < REMOVAL AND INSTALLATION >

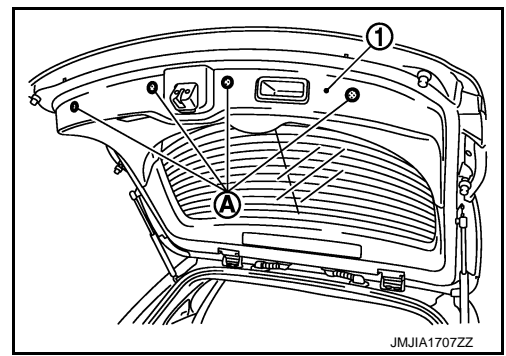
3. Remove the clips (A) from the back door finisher inner (1) with tool.



4. Disengage pull handle finisher (1) fixing pawls with remover tool (A) and then remove pull handle finisher.

 : Pawl

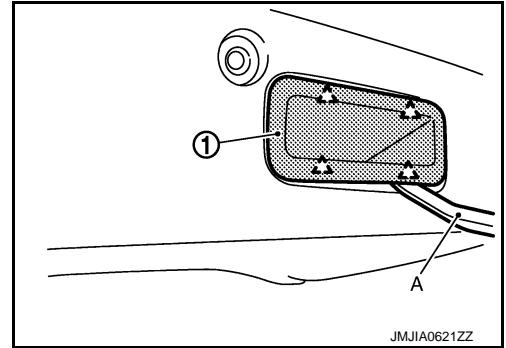

5. Remove the back door lamp. Refer to [INL-183, "BACK DOOR SIDE : Removal and Installation"](#).
6. Disengage the back door finisher lid (1) fixing pawls, then remove the back door finisher lid with remover tool (A).

 : Pawl

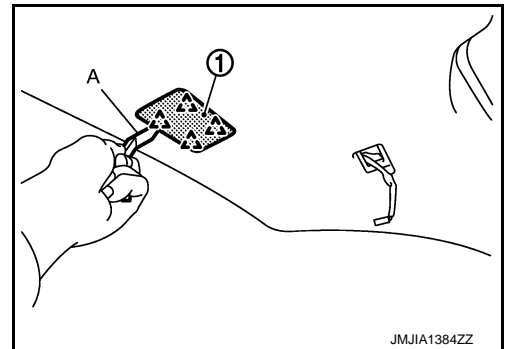

7. Remove the back door finisher inner.
  1. Insert remover tool (A) between back door finisher inner (1) and back door panel to disengage the clips.

**NOTE:**  
Starting from the lower downwards and works around the edges and up to the sides.

  2. Remove back door finisher inner.

 : Clip

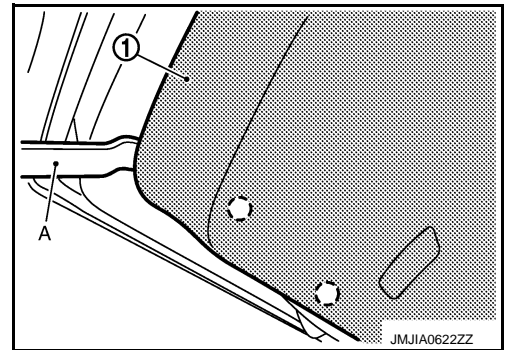

8. Pull out to remove back door finisher inner.

A  
B  
C  
D  
E  
F  
G  
H  
I  
INT  
K  
L  
M  
N  
O  
P

## BACK DOOR TRIM

### < REMOVAL AND INSTALLATION >

9. Disengage back door plate (1) fixing pawls and metal clips with remover tool (A) and then remove back door plate.

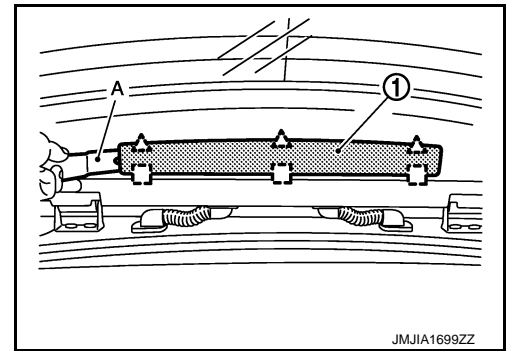
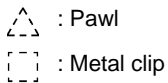

10. Disengage back door hinge cover (1) fixing pawls with remover tool (A) and then remove back door hinge cover.

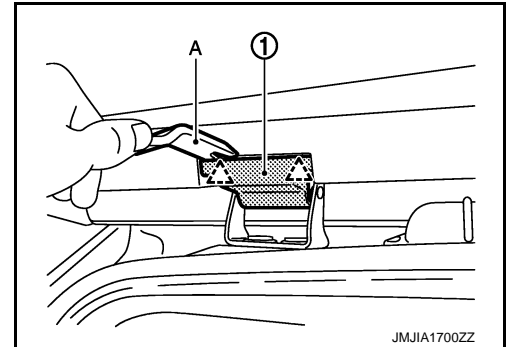
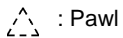

### INSTALLATION

Install in the reverse order of removal.

#### **CAUTION:**

**When installing back door trim, check that clips are securely fitted in panel holes on body, and then press them in.**